

Product Specification

XBLW SN74HC06

Hex Inverter with Open-drain outputs

WEB | www.xinboleic.com



Descriptions

The SN74HC06 contains six inverters. The outputs of the SN74HC06 is open-drain. The open-drain outputs require pull-up resistors to perform correctly.

Features

- Input levels: SN74HC06 CMOS level
- Specified from -40°C to +125°C
- Packaging information: DIP-14/SOP-14/TSSOP-14

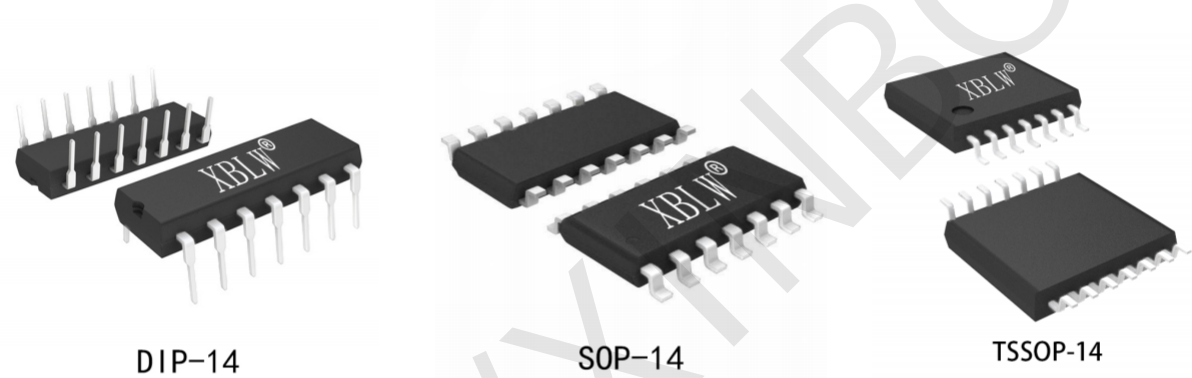

Ordering Information

Product Model	Package Type	Marking	Packing	Packing Qty
XBLW SN74HC06N	DIP-14	74HC06N	Tube	1000Pcs/Box
XBLW SN74HC06DTR	SOP-14	74HC06	Tape	2500Pcs/Reel
XBLW SN74HC06TDTR	TSSOP-14	74HC06	Tape	3000Pcs/Reel

Block Diagram

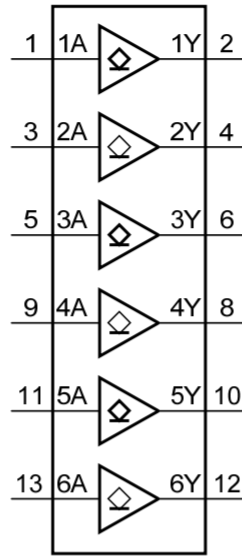

Figure 1. Logic symbol

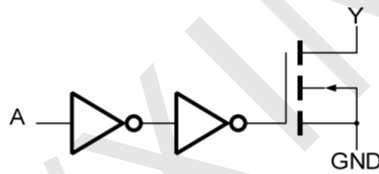
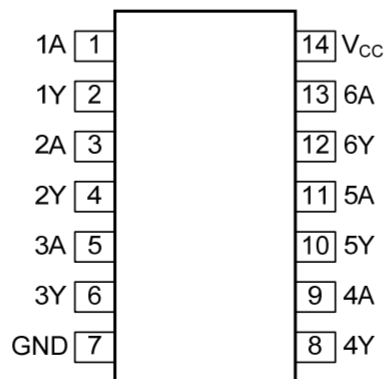

Figure 2. Logic diagram (one gate)

Pin Configurations



Pin Description

Pin No.	Pin Name	Description
1	1A	data input
2	1Y	data output
3	2A	data input
4	2Y	data output
5	3A	data input
6	3Y	data output
7	GND	ground (0V)
8	4Y	data output
9	4A	data input
10	5Y	data output
11	5A	data input
12	6Y	data output
13	6A	data input
14	V _{CC}	supply voltage

Function Table

Input	Output
nA	nY
L	Z
H	L

Note: H=HIGH voltage level; L=LOW voltage level; Z=high-impedance OFF-state.

Absolute Maximum Ratings

(Voltages are referenced to GND (ground=0V), unless otherwise specified.)

Parameter	Symbol	Conditions	Min.	Max.	Unit
supply voltage	V _{CC}	-	-0.5	+7.0	V
output voltage	V _O	-	-0.5	+7.0	V
input clamping current	I _{IK}	V _I <-0.5V or V _I >V _{CC} +0.5V	-	±20	mA
output clamping current	I _{OK}	V _O <-0.5V	-	-20	mA
output current	I _O	-0.5V<V _O	-	-25	mA
supply current	I _{CC}	-	-	+50	mA
ground current	I _{GND}	-	-50	-	mA
storage temperature	T _{stg}	-	-65	+150	°C
total power dissipation	P _{tot}	-	-	500	mW
soldering temperature	T _L	10s	DIP	245	°C
			SOP/TSSOP	260	

Recommended Operating Conditions

Parameter	Symbol	Conditions	Min.	Typ.	Max.	Unit
supply voltage	V_{CC}	-	2.0	5.0	6.0	V
input voltage	V_I	-	0	-	VCC	V
output voltage	V_O	-	0	-	VCC	V
ambient temperature	T_{amb}	-	-40	-	+125	°C

Electrical Characteristics

DC Characteristics 1

($T_{amb} = -40^{\circ}\text{C}$ to $+85^{\circ}\text{C}$, voltages are referenced to GND (ground=0V), unless otherwise specified.)

Parameter	Symbol	Conditions	Min.	Typ.	Max.	Unit	
HIGH-level input voltage	V_{IH}	$V_{CC}=2.0\text{V}$	1.5	1.2	-	V	
		$V_{CC}=4.5\text{V}$	3.15	2.4	-	V	
		$V_{CC}=6.0\text{V}$	4.2	3.2	-	V	
LOW-level input voltage	V_{IL}	$V_{CC}=2.0\text{V}$	-	0.8	0.5	V	
		$V_{CC}=4.5\text{V}$	-	2.1	1.35	V	
		$V_{CC}=6.0\text{V}$	-	2.8	1.8	V	
LOW-level output voltage	V_{OL}	$V_I = V_{IH}$ or V_{IL}	$I_O = 20\mu\text{A}; V_{CC} = 2.0\text{V}$	-	0	0.1	V
			$I_O = 20\mu\text{A}; V_{CC} = 4.5\text{V}$	-	0	0.1	V
			$I_O = 20\mu\text{A}; V_{CC} = 6.0\text{V}$	-	0	0.1	V
			$I_O = 4.0\text{mA}; V_{CC} = 4.5\text{V}$	-	0.15	0.33	V
			$I_O = 5.2\text{mA}; V_{CC} = 6.0\text{V}$	-	0.16	0.33	V
input leakage current	I_I	$V_I = V_{CC}$ or GND; $V_{CC} = 6.0\text{V}$	-	-	± 2	μA	
OFF-state output current	I_{OZ}	per input pin; $V_I = V_{IL}$; $V_O = V_{CC}$ or GND; other inputs at V_{CC} or GND; $V_{CC} = 6.0\text{V}$; $I_O = 0\text{A}$	-	-	± 2	μA	
supply current	I_{CC}	$V_I = V_{CC}$ or GND; $I_O = 0\text{A}$; $V_{CC} = 6.0\text{V}$	-	-	2	μA	
additional supply current	ΔI_{CC}	per input pin; $V_I = V_{CC} - 2.1\text{V}$; other inputs at V_{CC} or GND; $I_O = 0\text{A}$; $V_{CC} = 4.5\text{V}$ to 5.5V	-	100	450	μA	

DC Characteristics 2

(Tamb=-40°C to +125°C, voltages are referenced to GND (ground=0V), unless otherwise specified.)

Parameter	Symbol	Conditions	Min.	Typ.	Max.	Unit	
HIGH-level input voltage	V _{IH}	V _{CC} =2.0V	1.5	-	-	V	
		V _{CC} =4.5V	3.15	-	-	V	
		V _{CC} =6.0V	4.2	-	-	V	
LOW-level input voltage	V _{IL}	V _{CC} =2.0V	-	-	0.5	V	
		V _{CC} =4.5V	-	-	1.35	V	
		V _{CC} =6.0V	-	-	1.8	V	
LOW-level output voltage	V _{OL}	V _I =V _{IH} or V _{IL}	I _O =20uA; V _{CC} =2.0V	-	-	0.1	V
			I _O =20uA; V _{CC} =4.5V	-	-	0.1	V
			I _O =20uA; V _{CC} =6.0V	-	-	0.1	V
			I _O =4.0mA; V _{CC} =4.5V	-	-	0.4	V
			I _O =5.2mA; V _{CC} =6.0V	-	-	0.4	V
input leakage current	I _I	V _I =V _{CC} or GND; V _{CC} =6.0V	-	-	±4	uA	
OFF-state output current	I _{OZ}	per input pin; V _I =V _{IL} ; V _O =V _{CC} or GND; other inputs at V _{CC} or GND; V _{CC} =6.0V; I _O =0A	-	-	±4	uA	
supply current	I _{CC}	V _I =V _{CC} or GND; I _O =0A; V _{CC} =6.0V	-	-	4	uA	
additional supply current	ΔI _{CC}	per input pin; V _I =V _{CC} -2.1V; other inputs at V _{CC} or GND; I _O =0A; V _{CC} =4.5V to 5.5V	-	-	490	uA	

AC Characteristics 1

(Tamb=-40°C to +85°C, GND=0V, CL=50pF, unless otherwise specified.)

Parameter	Symbol	Conditions	Min.	Typ.	Max.	Unit	
nA to nY propagation delay	t _{pd}	see Figure 4 ^[1]	V _{CC} =2.0V	-	28	120	ns
			V _{CC} =4.5V	-	10	24	ns
			V _{CC} =5.0V; C _L =15pF	-	8	-	ns
			V _{CC} =6.0V	-	8	20	ns
transition time	t _t	see Figure 4 ^[2]	V _{CC} =2.0V	-	19	95	ns
			V _{CC} =4.5V	-	7	19	ns
			V _{CC} =6.0V	-	6	16	ns

Note:

[1] t_{pd} is the same as t_{PLZ} and t_{PZL}.

[2] t_t is the same as t_{THL}.

AC Characteristics 2

(Tamb=-40°C to +125°C, GND=0V, CL=50pF, unless otherwise specified.)

Parameter	Symbol	Conditions	Min.	Typ.	Max.	Unit	
nA to nY propagation delay	t _{pd}	see Figure 4 ^[1]	V _{CC} =2.0V	-	-	145	ns
			V _{CC} =4.5V	-	-	29	ns
			V _{CC} =6.0V	-	-	25	ns
transition time	t _t	see Figure 4 ^[2]	V _{CC} =2.0V	-	-	110	ns
			V _{CC} =4.5V	-	-	22	ns
			V _{CC} =6.0V	-	-	19	ns

Note:

[1] t_{pd} is the same as t_{PLZ} and t_{PZL}.

[2] t_t is the same as t_{THL}.

Testing Circuit

AC Testing Circuit

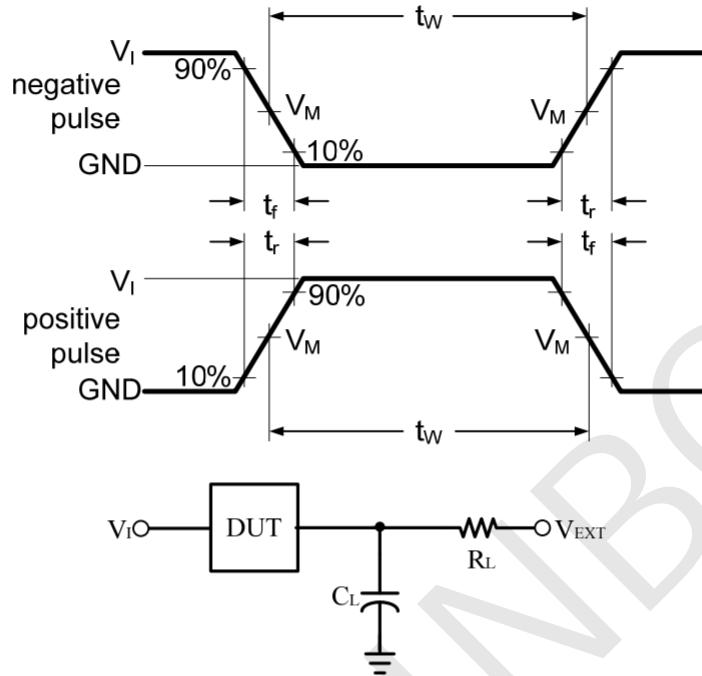

Figure 3. Test circuit for measuring switching times

C_L includes probe and jig capacitance.

AC Testing Waveforms

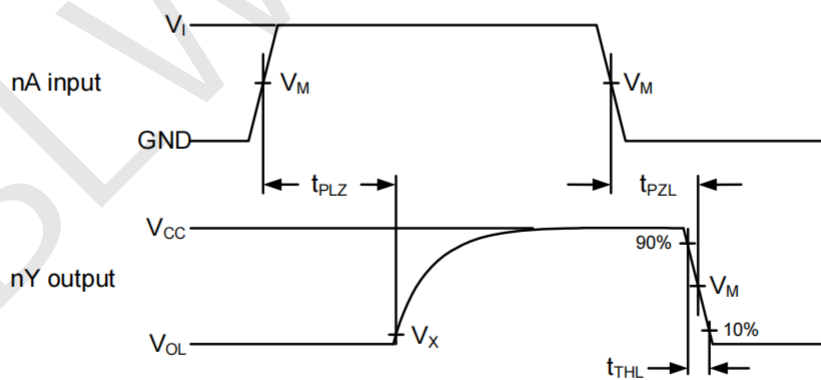

Figure 4. The input nA to output nY propagation delays and output transition times

Measurement Points

Type	Input	Output	
	V_M	V_M	V_X
SN74HC06	$0.5 \times V_{CC}$	$0.5 \times V_{CC}$	$0.1 \times V_{CC}$

Test Data

Type	Input		Load		S1 position
	V_I	t_r, t_f	C_L	R_L	t_{PZL}, t_{PLZ}
SN74HC06	V_{CC}	6ns	15pF, 50pF	1k Ω	V_{CC}

Package Information

· DIP-14

Size Symbol	Dimensions In Millimeters		Size Symbol	Dimensions In Inches	
	Min (mm)	Max (mm)		Min (in)	Max (in)
A	3.710	4.310	A	0.146	0.170
A1	0.510		A1	0.020	
A2	3.200	3.600	A2	0.126	0.142
B	0.380	0.570	B	0.015	0.022
B1	1.524 (BSC)		B1	0.060 (BSC)	
C	0.204	0.360	C	0.008	0.014
D	18.800	19.200	D	0.740	0.756
E	6.200	6.600	E	0.244	0.260
E1	7.320	7.920	E1	0.288	0.312
e	2.540 (BSC)		e	0.100 (BSC)	
L	3.000	3.600	L	0.118	0.142
E2	8.400	9.000	E2	0.331	0.354

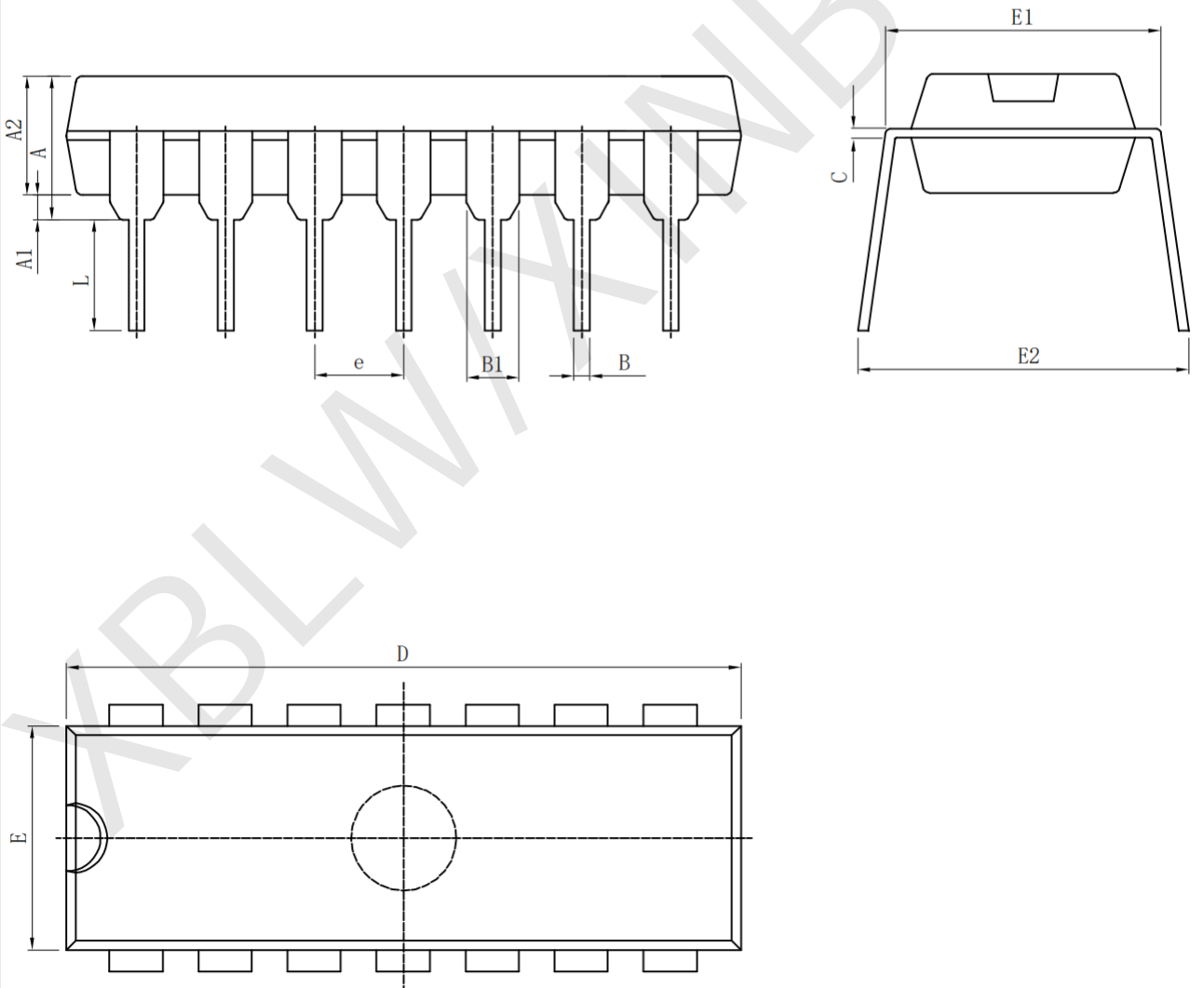

· SOP-14

Symbol	Dimensions In Millimeters		Symbol	Dimensions In Inches	
	Min (mm)	Max (mm)		Min (in)	Max (in)
A	1.350	1.750	A	0.050	0.068
A1	0.100	0.250	A1	0.004	0.009
A2	1.100	1.650	A2	0.040	0.060
B	0.330	0.510	B	0.010	0.020
C	0.190	0.250	C	0.007	0.009
D	8.550	8.750	D	0.330	0.340
E	3.800	4.000	E	0.150	0.150
e	1.27		e	0.05	
H	5.800	6.200	H	0.220	0.240
h	0.250	0.500	h	0.009	0.020
L	0.400	1.270	L	0.015	0.050
k	8° (max)		k	8° (max)	

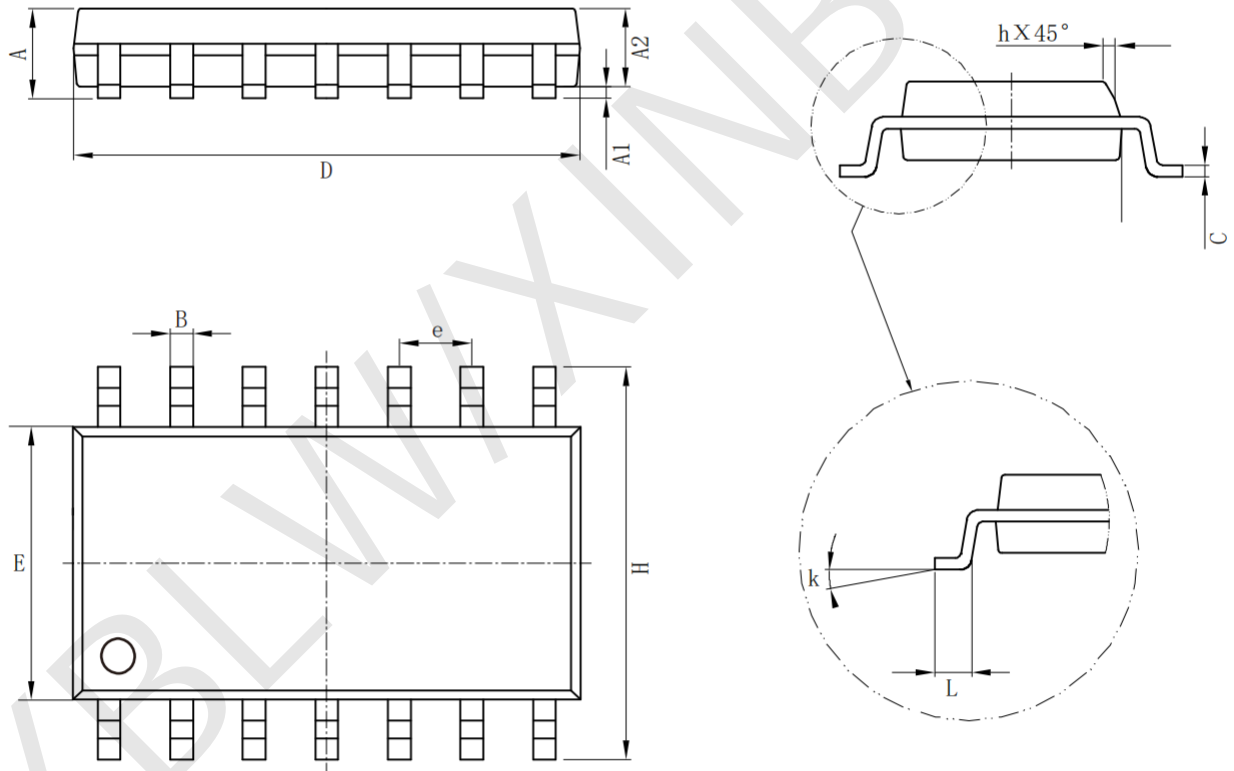

· TSSOP-14

Symbol	Dimensions In Millimeters		Symbol	Dimensions In Inches	
	Min (mm)	Max (mm)		Min (in)	Max (in)
A		1.200	A		0.047
A1	0.050	0.150	A1	0.002	0.006
A2	0.800	1.050	A2	0.031	0.041
b	0.190	0.300	b	0.007	0.012
c	0.090	0.200	c	0.004	0.0089
D	4.900	5.100	D	0.193	0.201
E	6.200	6.600	E	0.244	0.260
E1	4.300	4.500	E1	0.169	0.176
e	0.65		e	0.0256	
L	0.450	0.750	L	0.018	0.030
L1	1.00		L1	0.039	
k	0°	8°	k	0°	8°

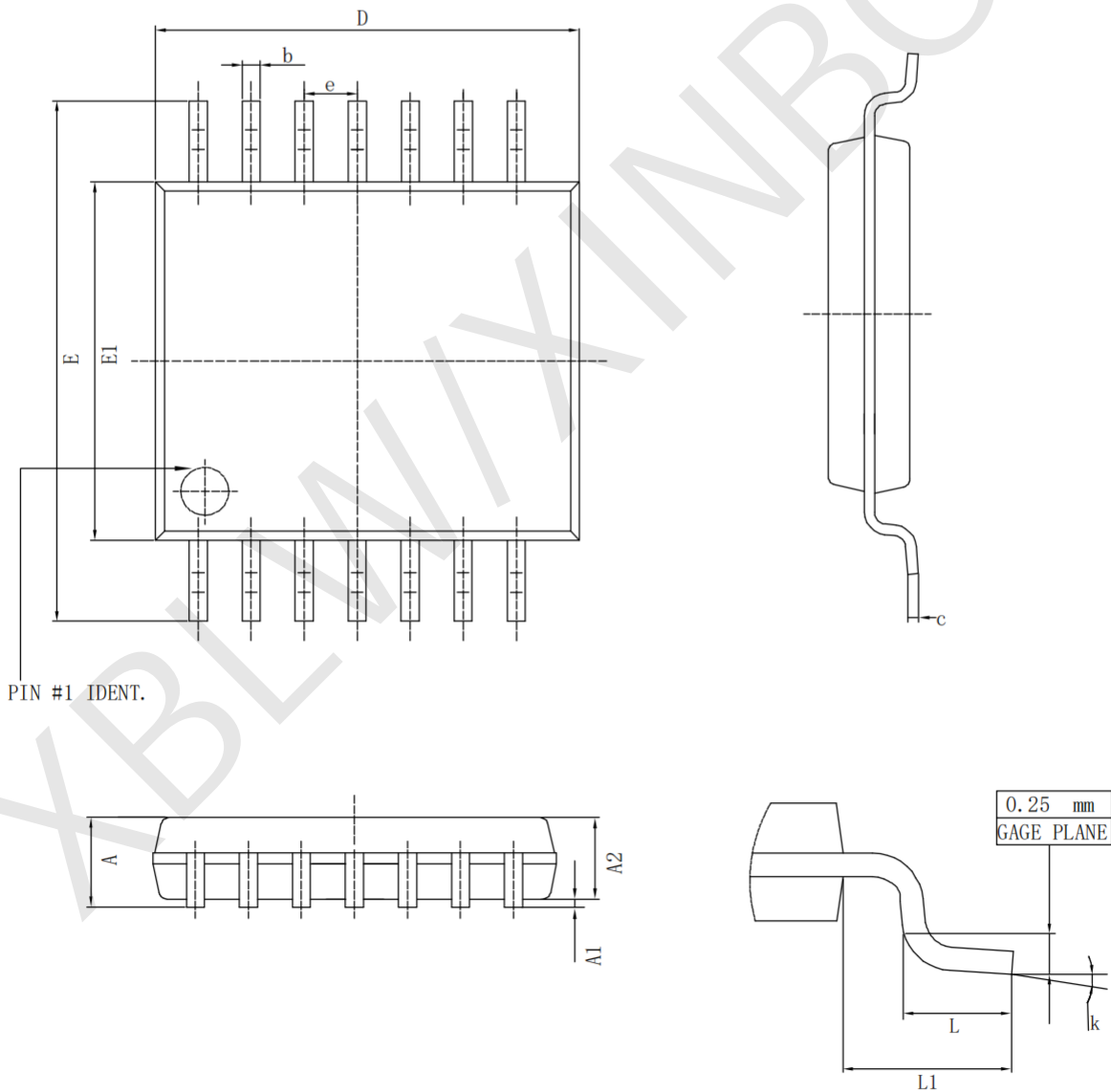

Statement:

- XBLW reserves the right to modify the product manual without prior notice! Before placing an order, customers need to confirm whether the obtained information is the latest version and verify the completeness of the relevant information.
- Any semiconductor product may malfunction under specified conditions. When using XBLW products for system design and overall manufacturing, the buyer is responsible for complying with safety standards and taking appropriate safety measures to avoid risks that may cause personal injury or property damage.
- XBLW products have not been licensed for life support, military, and aerospace applications, and therefore XBLW is not responsible for any consequences arising from the use of this product in these areas.
- If any or all XBLW products (including technical data, services) described or contained in this document are subject to any applicable local export control laws and regulations, they may not be exported without an export license from the relevant authorities in accordance with such laws.
- The specifications of any and all XBLW products described or contained in this document specify the performance, characteristics, and functionality of said products in their standalone state, but do not guarantee the performance, characteristics, and functionality of said products installed in Customer's products or equipment. In order to verify symptoms and conditions that cannot be evaluated in a standalone device, the Customer should ultimately evaluate and test the device installed in the Customer's product device.
- XBLW documentation is only allowed to be copied without any alteration of the content and with the relevant authorization. XBLW assumes no responsibility or liability for altered documents.
- XBLW is committed to becoming the preferred semiconductor brand for customers, and XBLW will strive to provide customers with better performance and better quality products.