

GENERAL DESCRIPTION

The LW57XX Series is an ultra-low noise, high PSRR LDO with enable function that operates from 1.9V to 5.5V. It provides up to 500mA output current.

The features of low noise and high PSRR make LW57XX ideal for noise-sensitive and analog applications.

The LW57XX Series integrate current limit, thermal shut down, that protecting IC from being damaged.

Output voltage is selectable from 1.2V to 5.0V which fixed by laser trimming technologies, Step=100mV.

The LW57XX Series is available in SOT23-5L, DFN1x1-4L and DFN2x2-6L packages.

TYPICAL APPLICATION CIRCUIT

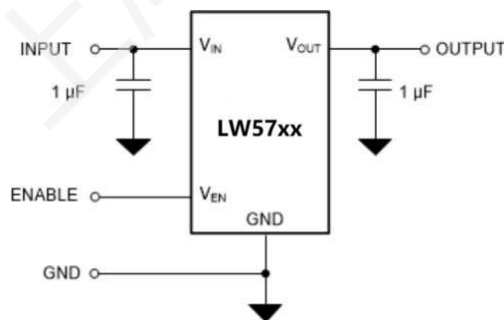

FEATURES

- Low Quiescent Current: 10µA(Typ.)
- Operating Voltage Range: from 1.9V to 5.5V
- Output Voltage Range: from 1.2V to 5.0V
- Maximum Output Current: 500mA
- Output Accuracy: $\pm 1\%$ @+25°C
- Low Dropout Voltage: 180mV@500mA/3.3V
- High PSRR: 90dB@1KHz,10mA
- Ultra-Low Noise: 5.3µVRMS
- Current Limiting Protection
- Over-Temperature Protection
- Fast-Start Function
- Stable with 1µF Output Capacitor

APPLICATIONS

- Mobile Phones, Tablets, Digital Cameras
- Audio Devices
- RF Modules
- Clock Generator: VCO, PLL, etc.
- Noise-Sensitive Devices: ADC, DAC

TYPICAL PERFORMANCE CHARACTERISTICS

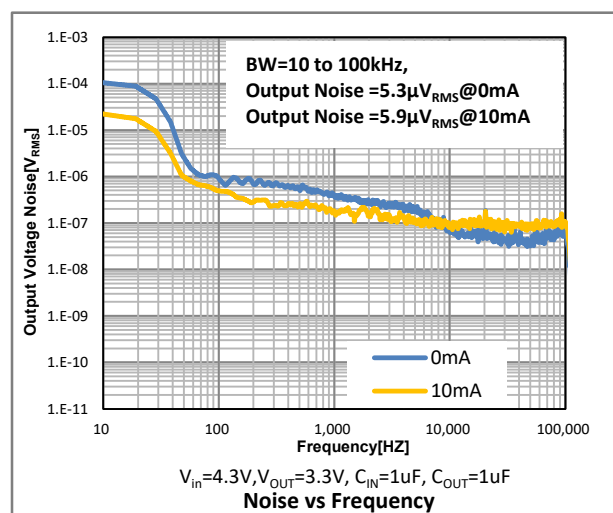

PIN DESCRIPTION:

PIN No			SYMBOL	DESCRIPTION
SOT23-5L	DFN1x1-4L	DFN2x2-6		
1	4	6	VIN	Input pin. For best transient response and to minimize input impedance, use the recommended value or larger ceramic capacitor from IN to ground as listed in the Recommended Operating Conditions table and the Input and Output Capacitor Requirements section. Place the input capacitor as close to the output of the device as possible.
2	2	3	GND	Ground pin.
3	3	4	EN	Enable pin. Drive EN greater than $V_{EN(HI)}$ to turn on the regulator. Drive EN less than $V_{EN(LO)}$ to put the low-dropout regulator (LDO) into shutdown mode.
4	--	2,5	NC	No internal connection. Ground this pin for better thermal performance.
5	1	1	VOUT	Regulated output voltage pin. Connect a low-equivalent series resistance (ESR) capacitor to this pin. For best transient response, use the nominal recommended value or larger capacitor from OUT to GND. An internal pulldown resistor prevents a charge from remaining on OUT when the regulator is in shutdown mode ($V_{EN} < V_{EN(LOW)}$).
--	Thermal Pad	Thermal Pad	Pad	The thermal pad is electrically connected to the GND node. Connect to the GND plane for improved thermal performance.

PIN ASSIGNMENT

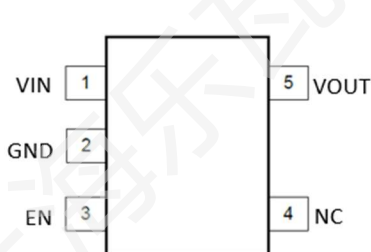

SOT23-5L

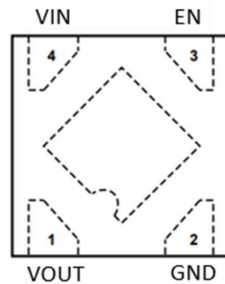

DFN1x1-4L

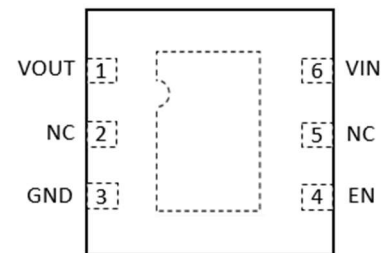

DFN2x2-6L

MARK INFORMATION:

SOT23-5L

XX: VOLTAGE

YY: DATE CODE

LW57XX
YYYYY

DFN2x2-6L

XX: VOLTAGE

YY: DATE CODE

LW57XX
•
YYYYY

DFN1X1-4L

X: VOLTAGE

57X
•

1.2V	1.5V	1.8V	2.5V	2.8V	3.0V	3.3V	3.6V	4.2V	5.0V
C	D	G	H	J	L	M	P	S	T

ABSOLUTE MAXIMUM RATINGS ⁽¹⁾:

(T_A =25°C, unless otherwise specified.)

SYMBOL	ITEM	RATING	UNIT
V _{IN}	Supply Voltage	-0.3~6.5	V
V _{EN}	EN Pin Voltage	-0.3~6.5	V
V _{OUT}	VOUT Pin Voltage	-0.3~6.0	V
V _(ESD)	ESD Susceptibility, HBM ⁽²⁾	±4000	V
R _{θJA}	Junction-to-ambient Thermal Resistance ⁽³⁾	SOT23-5L	188
		DFN1x1-4L	180
		DFN2x2-6L	73
T _J	Junction Temperature Range	-40~150	°C
T _{STG}	Storage Temperature Range	-40~150	°C
T _{SOLDER}	Lead Temperature (Soldering)	260°C, 10s	

Note:

1. Stresses beyond those listed under Absolute Maximum Ratings may cause permanent damage to the device. These are stress ratings only, and functional operation of the device at these or any other conditions beyond those indicated under Recommended Operating Conditions is not implied. Exposure to absolute-maximum-rated conditions for extended periods may affect device reliability
2. per ANSI/ESDA/JEDEC JS-001
3. Device mounted on FR-4 PCB, Refer to JESD51-3 for detailed information on the board construction

RECOMMENDED OPERATING RANGE:

SYMBOL	ITEM	VALUE	UNIT
V _{IN}	VIN Supply Voltage	1.9~5.5	V
V _{EN}	EN Pin Voltage	0~5.5	V
V _{OUT}	VOUT Pin Voltage	1.2~5.0	V
I _{OUT}	Output Current	0~500	mA
T _J	Junction Temperature Range	-40~125	°C

ELECTRICAL CHARACTERISTICS:

($V_{IN}=V_{OUT(NOM)}+1V$ or $2V$, whichever is greater, $C_{IN}=C_{OUT}=1\mu F$, unless otherwise specified, typical values are at $T_A = 25^\circ C$.)

Symbol	Parameter	Test Conditions	MIN	TYP	MAX	Units
V_{IN}	Input Voltage		1.9		5.5	V
V_{OUT}	Output Accuracy	$I_{OUT}=1mA$	-1.0		+1.0	%
I_{LIM}	Current Limit ⁽¹⁾		550	700		mA
I_Q	Quiescent Current	$V_{IN}=V_{EN}=V_{OUT}+1V$, No Load		10	15	μA
I_{SHD}	Shutdown Current	$V_{EN}=0V$			0.1	μA
V_{DROP}	Dropout Voltage ⁽¹⁾⁽²⁾	$I_{OUT}=100mA, V_{OUT}=1.2V$		110		mV
		$I_{OUT}=500mA, V_{OUT}=1.2V$		510		
		$I_{OUT}=100mA, V_{OUT}=3.3V$		30		
		$I_{OUT}=500mA, V_{OUT}=3.3V$		180		
		$I_{OUT}=100mA, V_{OUT}=5V$		30		
		$I_{OUT}=500mA, V_{OUT}=5V$		160		
$\frac{\Delta V_{OUT}}{(\Delta V_{IN} * V_{OUT(NOM)})}$	Line Regulation	$V_{IN}=V_{OUT}+1V$ to $5.5V, I_{OUT}=1mA$		0.05	0.25	%/V
ΔV_{OUT}	Load Regulation	$1mA \leq I_{OUT} \leq 500mA$		20	60	mV
I_{EN}	EN Pull-Down Current	$V_{IN}=V_{EN}=5.5V$		0.15		μA
V_{ENH}	EN High Voltage	$V_{IN}=1.9V$ to $5.5V, I_{OUT}=1mA$	1.5			V
V_{ENL}	EN Low Voltage				0.5	V
PSRR	Power Supply Rejection Ratio	$V_{IN}=4.3V, V_{OUT}=3.3V$ $C_{IN}=None, V_{PP}=0.5V$ $I_{OUT}=10mA$	$f=217Hz$		90	dB
			$f=1KHz$		90	
			$f=10KHz$		88	
			$f=100KHz$		60	
e_n	Output Voltage Noise	$f=10Hz$ to $100kHz,$ $V_{IN}=4.3V, V_{OUT}=3.3V$	$I_{OUT}=0mA$		5.3	μV_{RMS}
			$I_{OUT}=10mA$		5.9	
T_{SD}	Thermal Shutdown	Temperature rising		160		$^\circ C$
ΔT_{SD}	TSD Hysteresis	Temperature falling		20		$^\circ C$
R_{DSCHG}	Output Discharge Resistance	$V_{IN}=5.5V, V_{EN}=0V$		60		Ω

NOTES:

1. Guaranteed by design
2. The dropout voltage is defined as $V_{IN} - V_{OUT}$, when $V_{OUT}=95%*V_{OUT(NOM)}$

SIMPLIFIED BLOCK DIAGRAM:

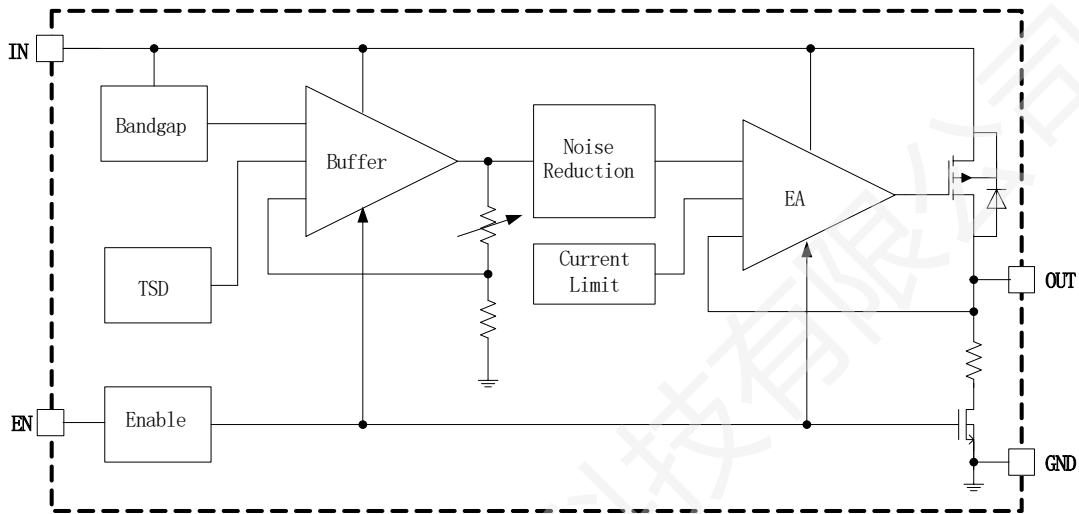

DETAIL OPERATION DESCRIPTION:

The LW57XX is a low noise, high PSRR LDO voltage regulator featuring high integration and multiple protection mechanisms. It utilizes a Bandgap reference and an Error Amplifier (EA) to ensure stable output. Key modules include a Buffer for driving, a Noise Reduction block for low noise performance, and a Current Limit function for safety. Additionally, it integrates an Enable control and a Thermal Shutdown (TSD) protection feature.

Error Amplifier

The Error Amplifier (EA) compares the internal reference voltage V_{REF} with the output feedback voltage. Output of the error amplifier (EA) is used to control the gate voltage of P-MOSFET and ensures that the device provides good line and load regulation.

Current Limit Protection

LW57XX provides current limiting function to prevent the device from damaging during overload. The output current is limited to 700mA (typ.)

Thermal Shutdown Protection

When the junction temperature exceeds 160°C (typ.), thermal shutdown is triggered and the device turns off. When the junction temperature falls below 140°C (typ.), the device turns on again.

TYPICAL OPERATING CHARACTERISTICS:

(Tested under $T_A = 25^\circ\text{C}$, $C_{IN} = C_{OUT} = 1\mu\text{F}$, unless otherwise specified)

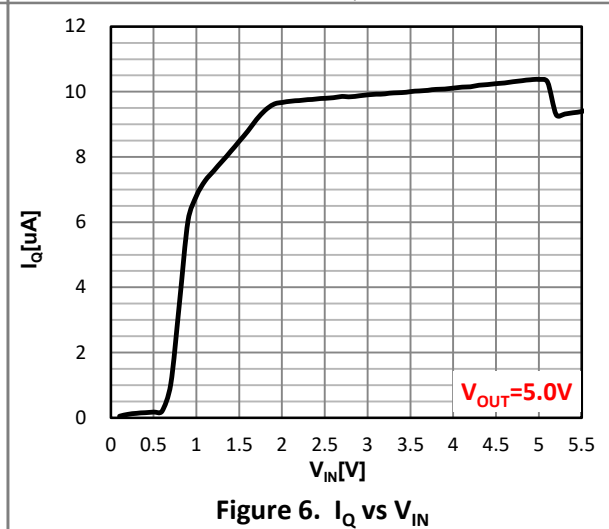
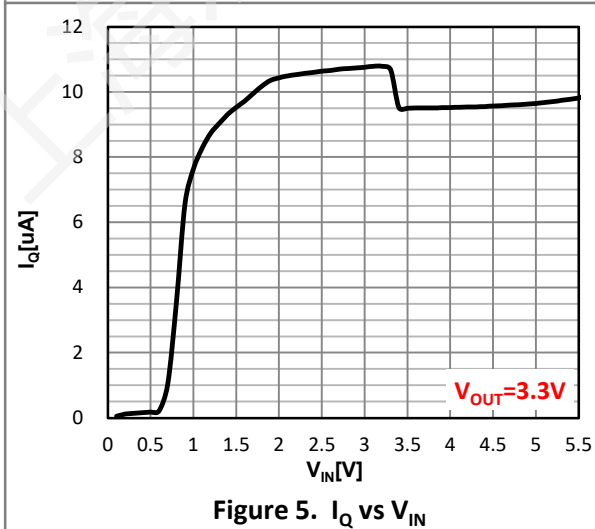
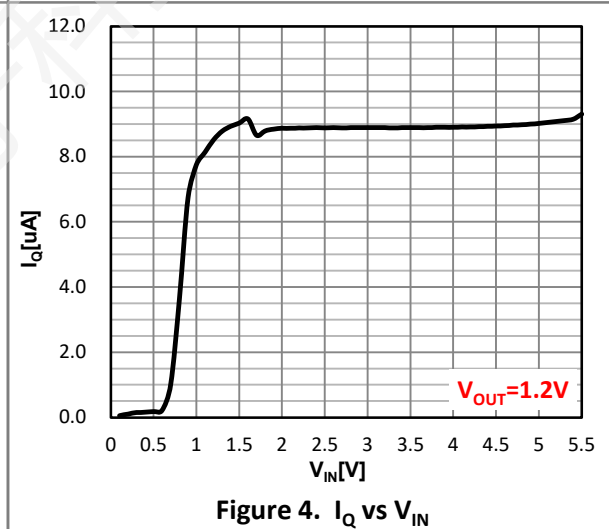
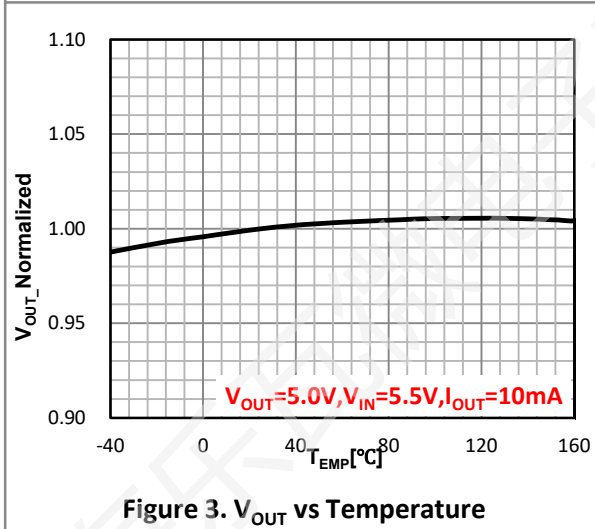
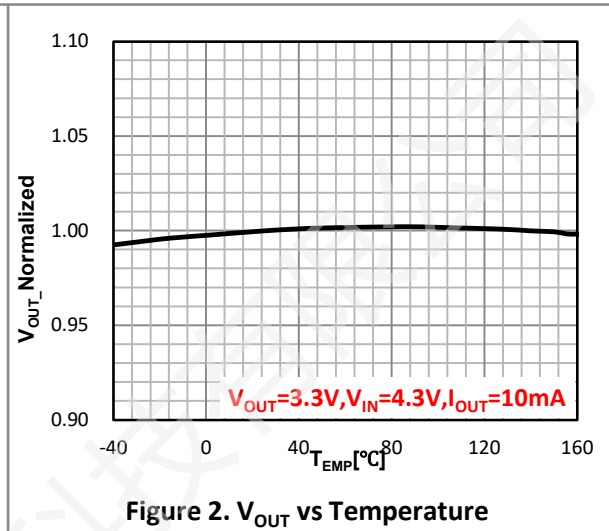
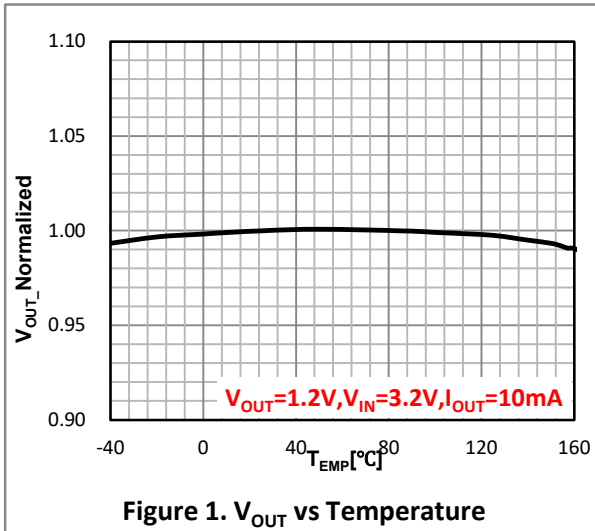

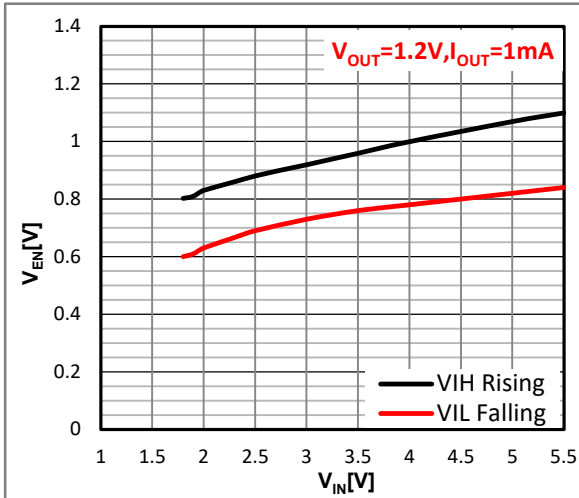

Figure 7. V_{EN} VS V_{IN}

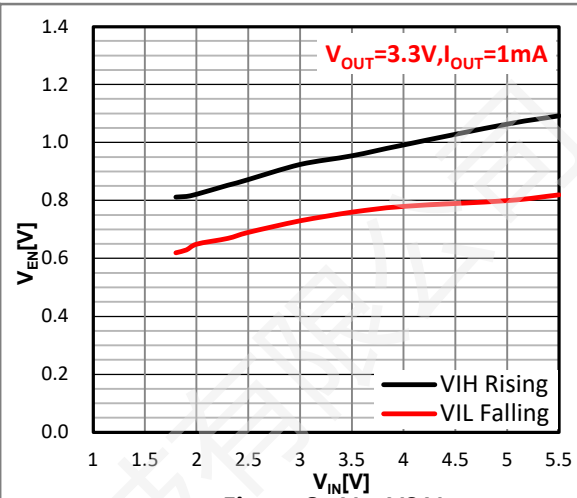

Figure 8. V_{EN} VS V_{IN}

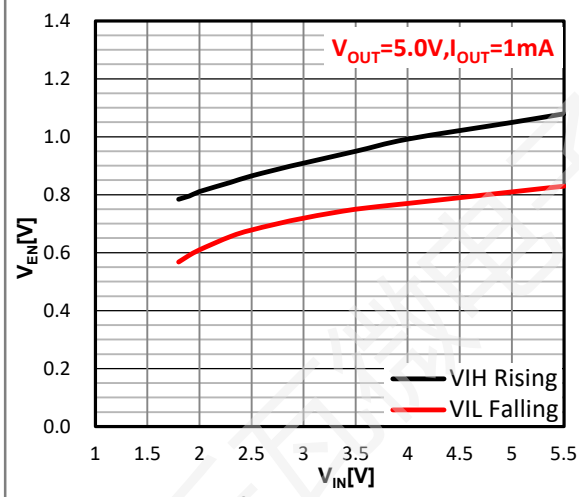

Figure 9. V_{EN} VS V_{IN}

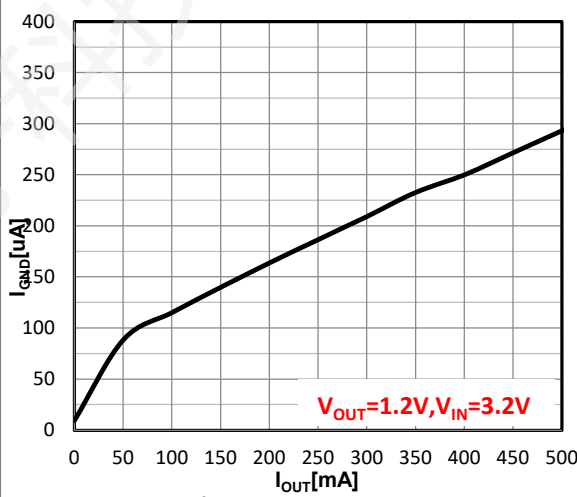

Figure 10. I_{GND} vs I_{OUT}

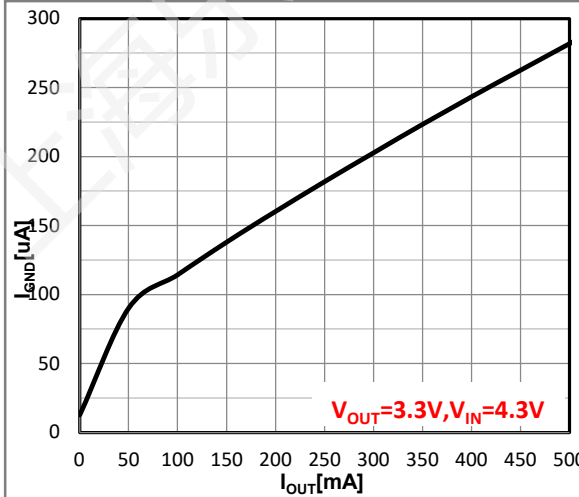

Figure 11. I_{GND} vs I_{OUT}

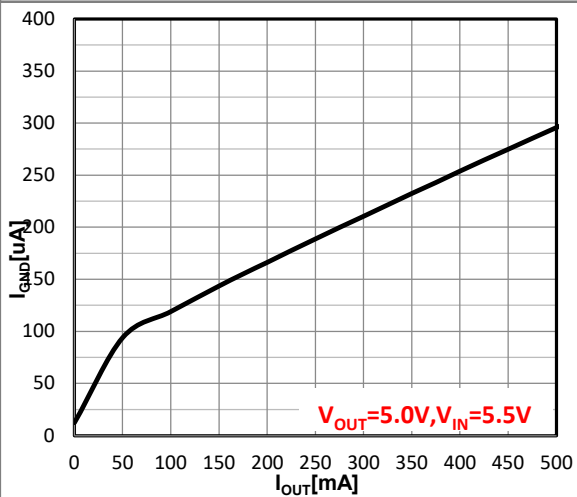

Figure 12. I_{GND} vs I_{OUT}

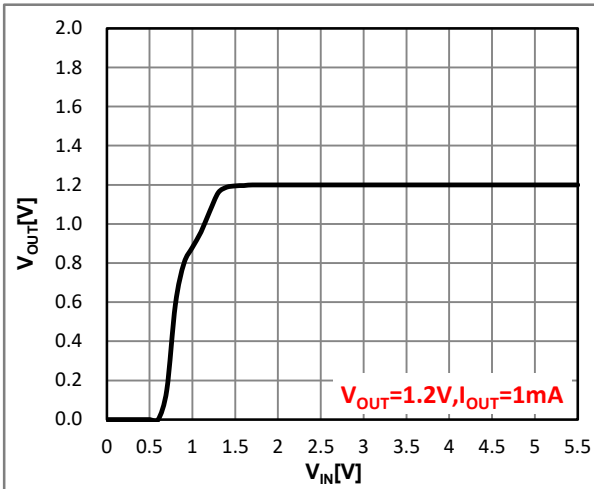

Figure 13. V_{OUT} vs V_{IN}

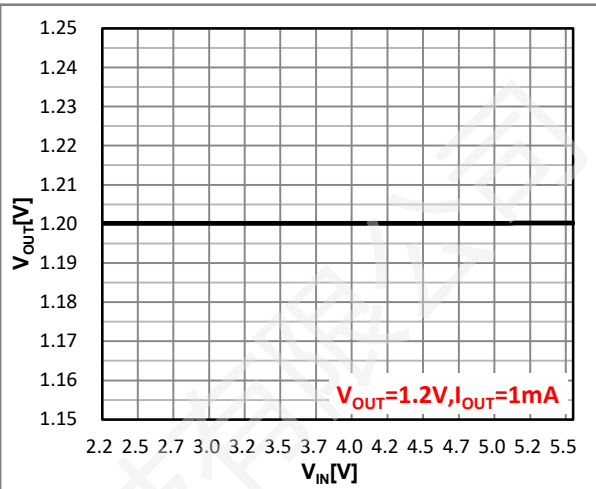

Figure 14. Line Regulation

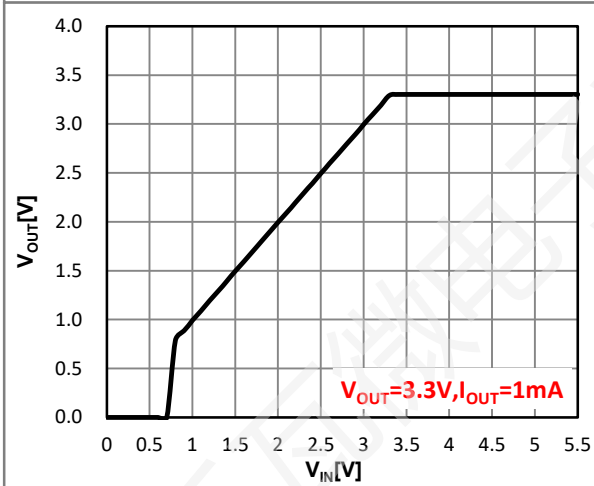

Figure 15. V_{OUT} vs V_{IN}

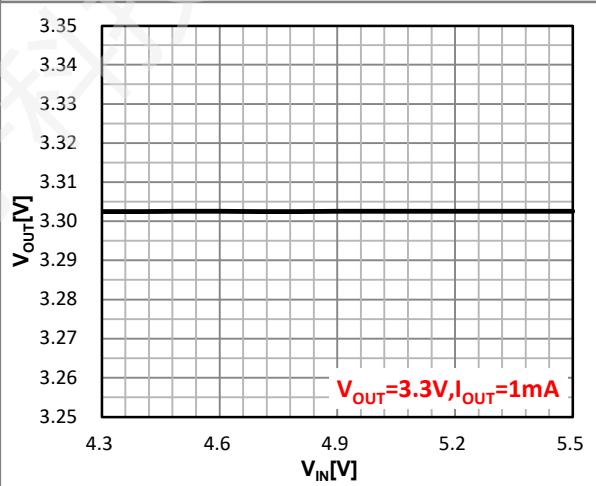

Figure 16. Line Regulation

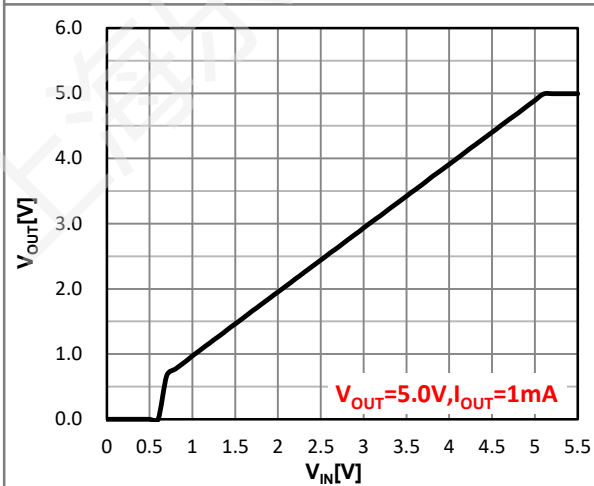

Figure 17. V_{OUT} vs V_{IN}

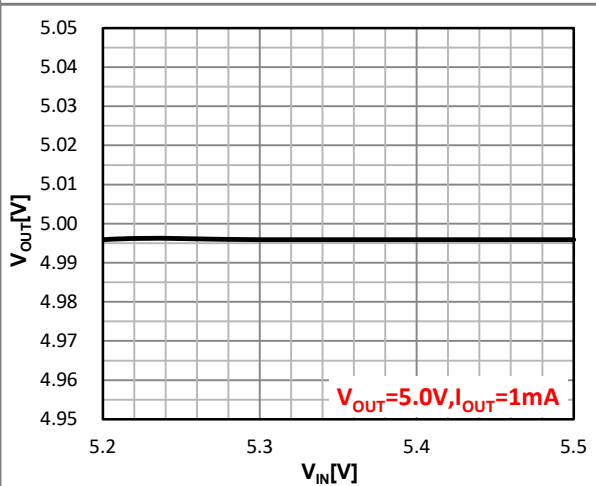

Figure 18. Line Regulation

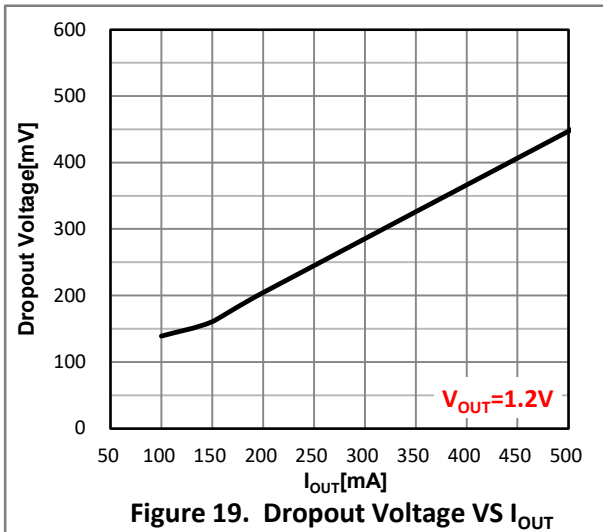

Figure 19. Dropout Voltage VS I_{OUT}

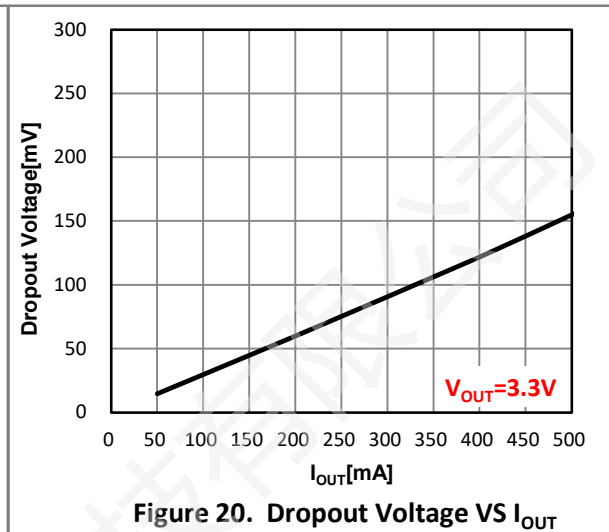

Figure 20. Dropout Voltage VS I_{OUT}

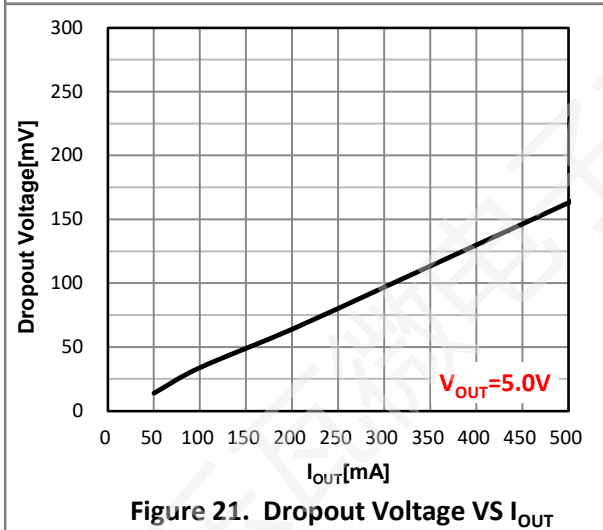

Figure 21. Dropout Voltage VS I_{OUT}

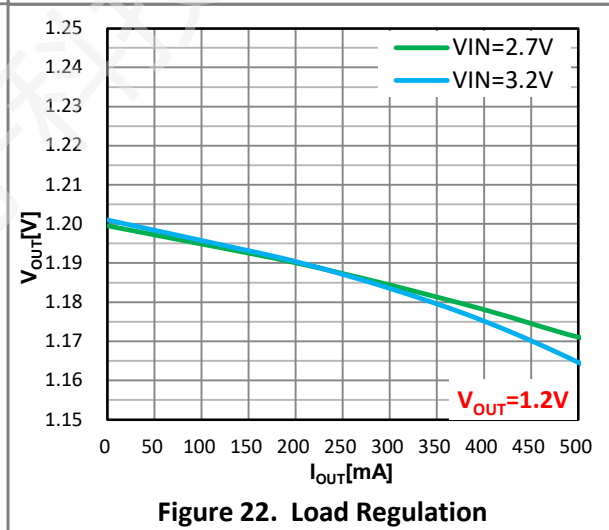

Figure 22. Load Regulation

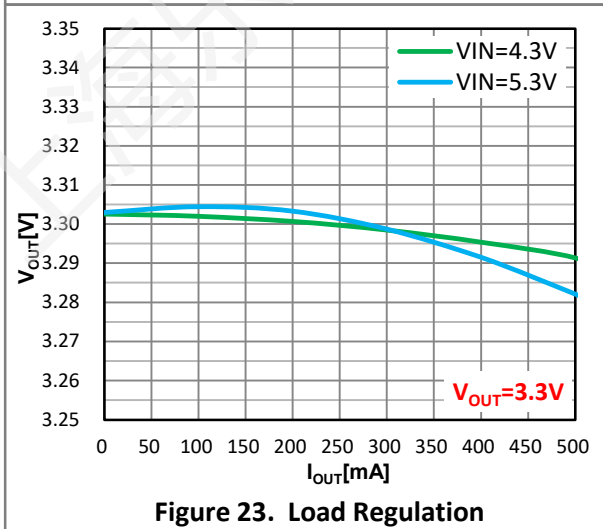

Figure 23. Load Regulation

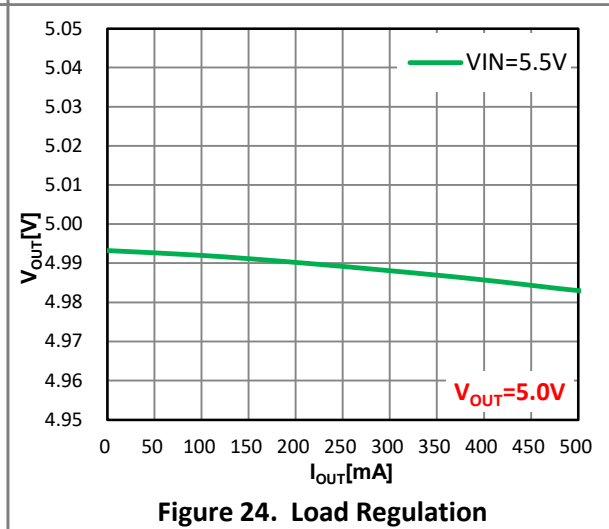
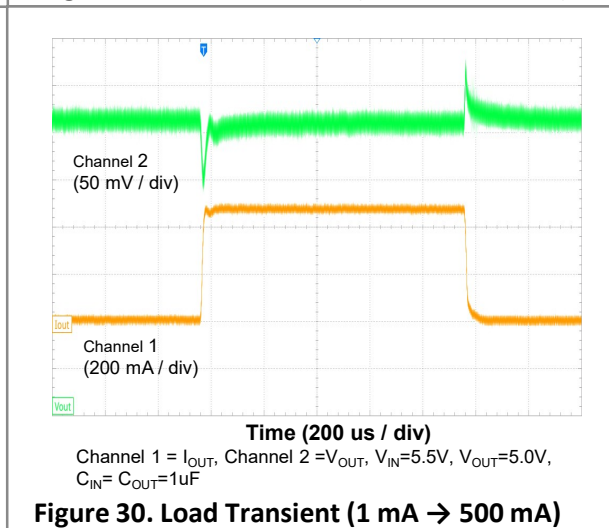
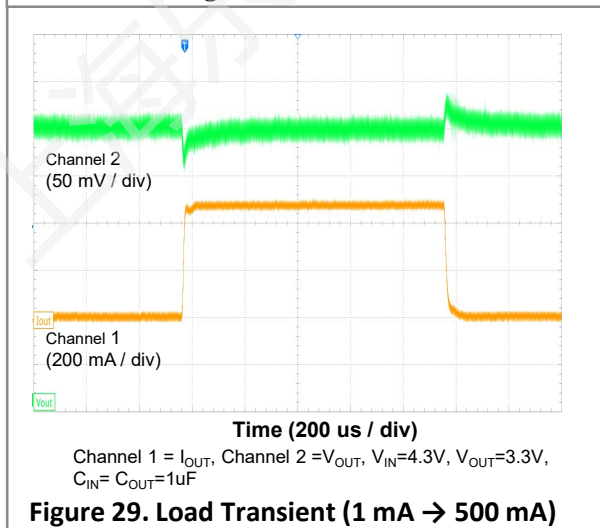
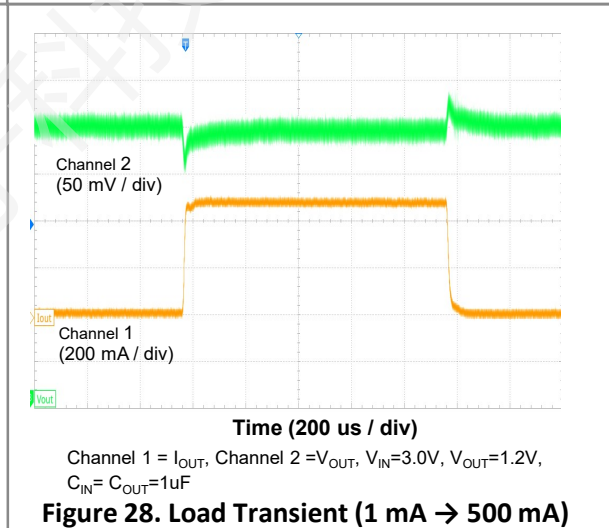
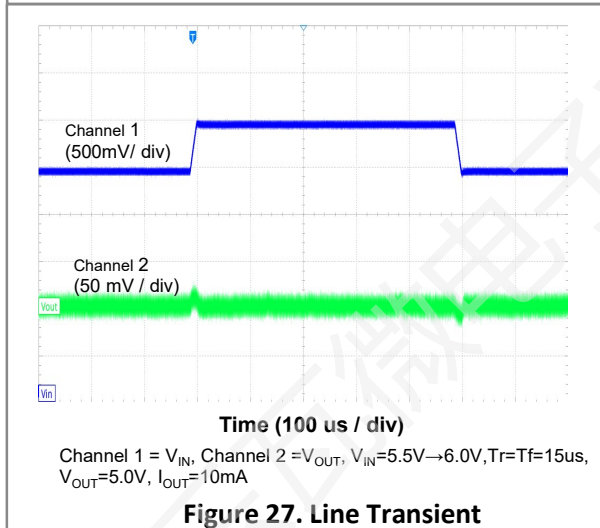
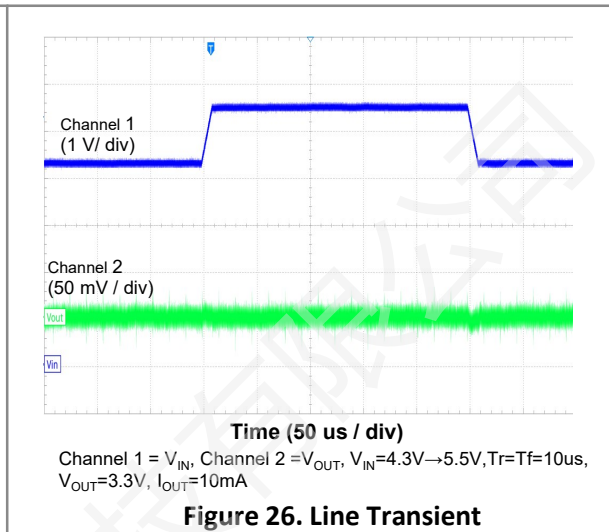
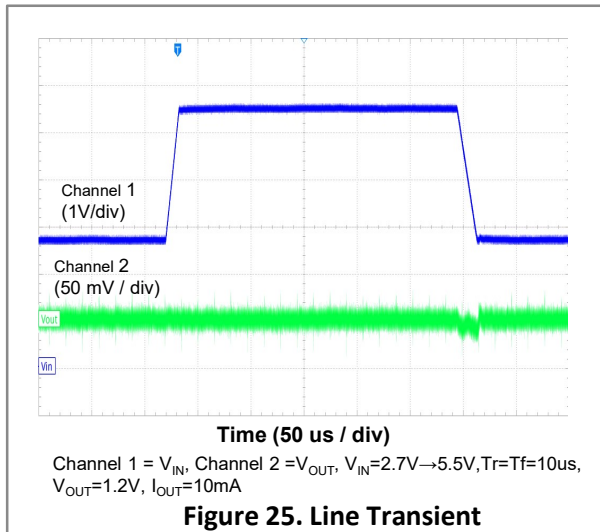
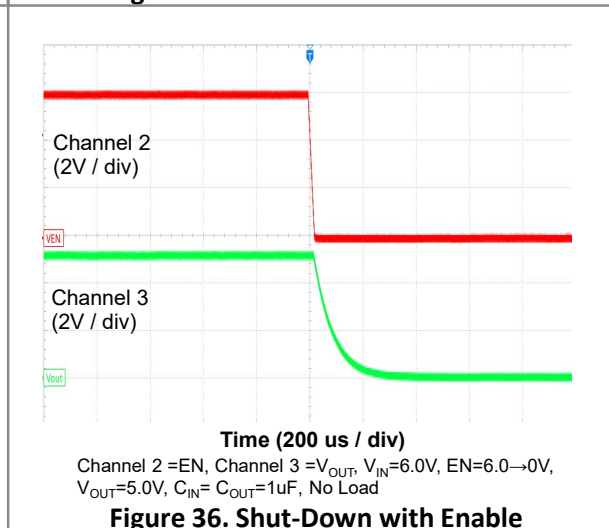
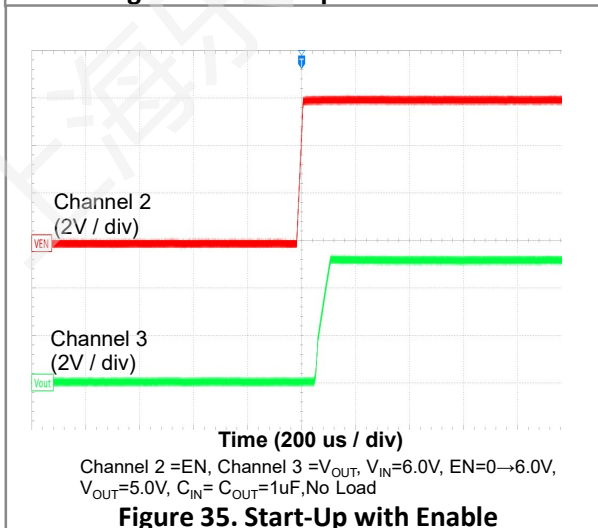
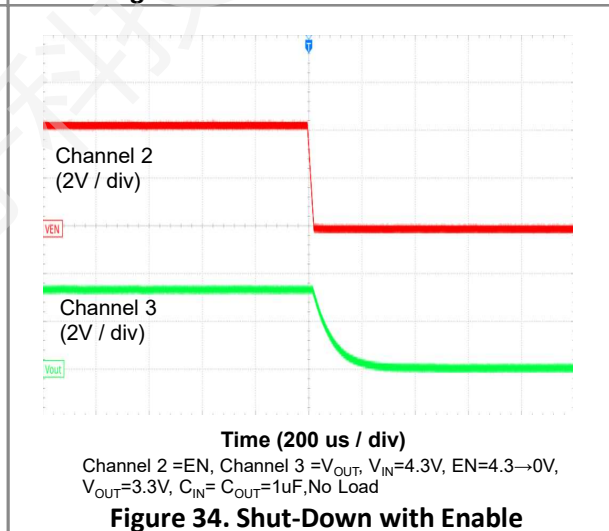
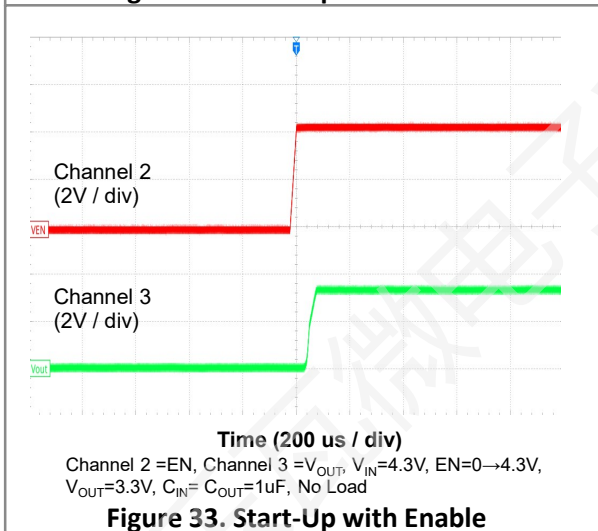
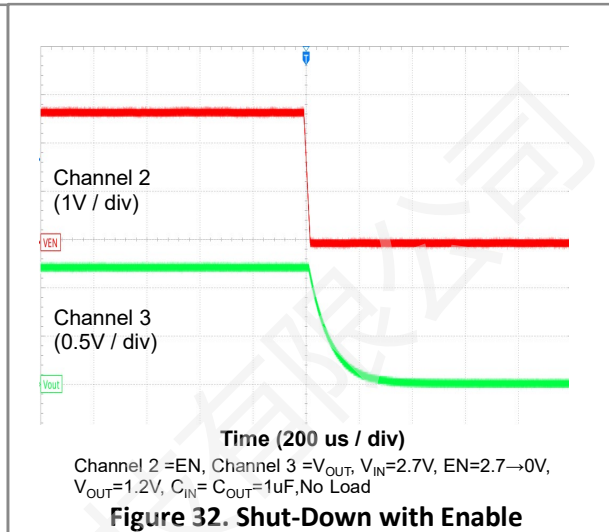
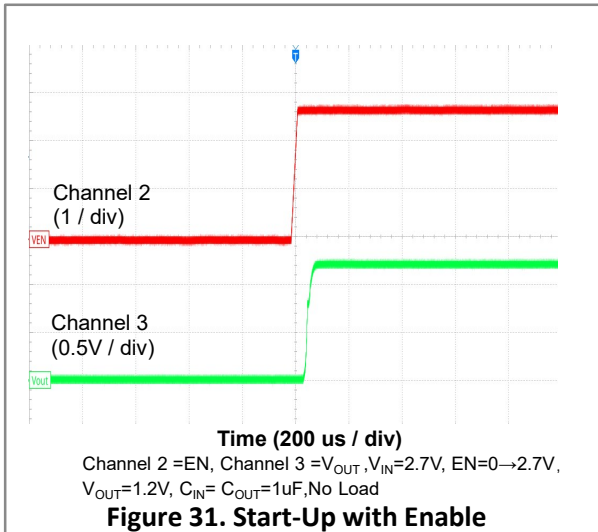
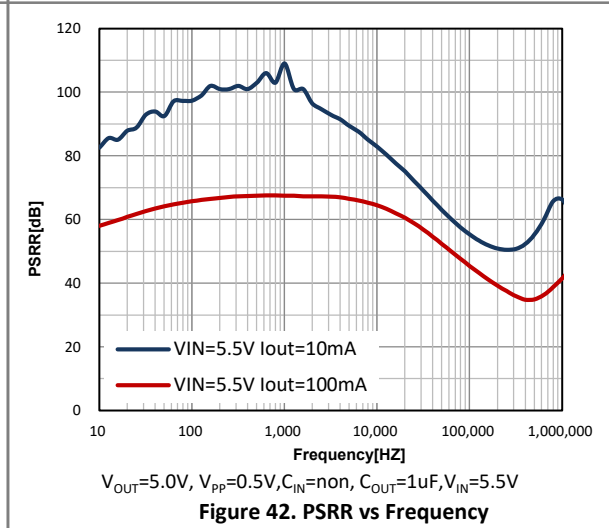
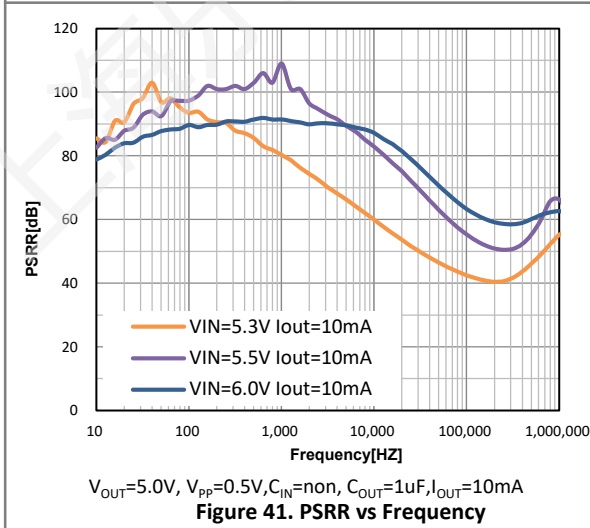
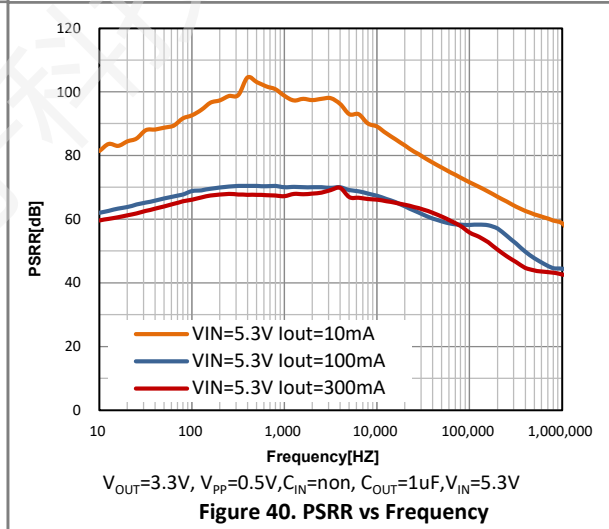
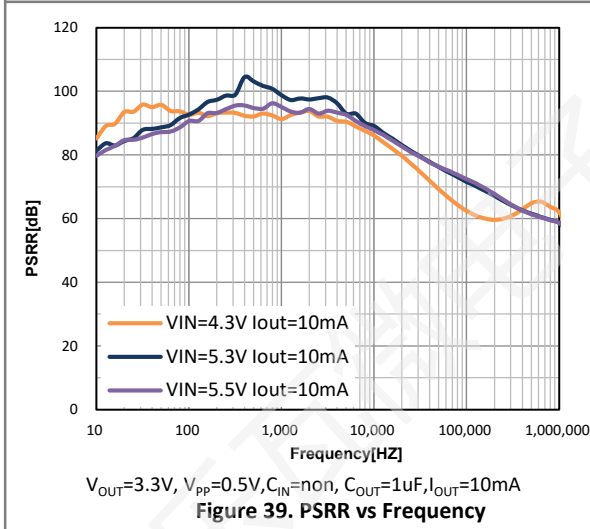
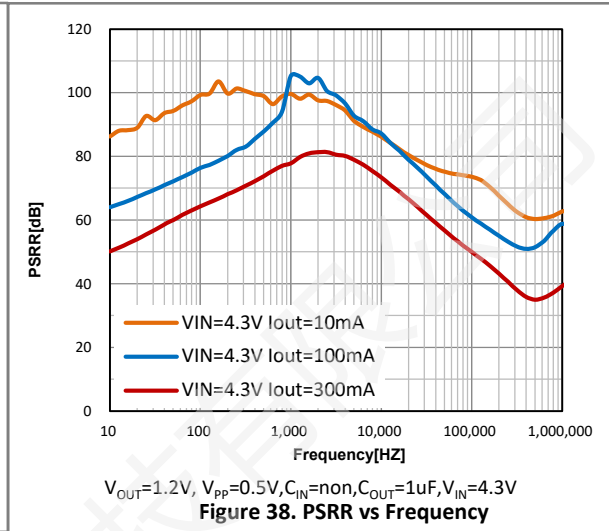
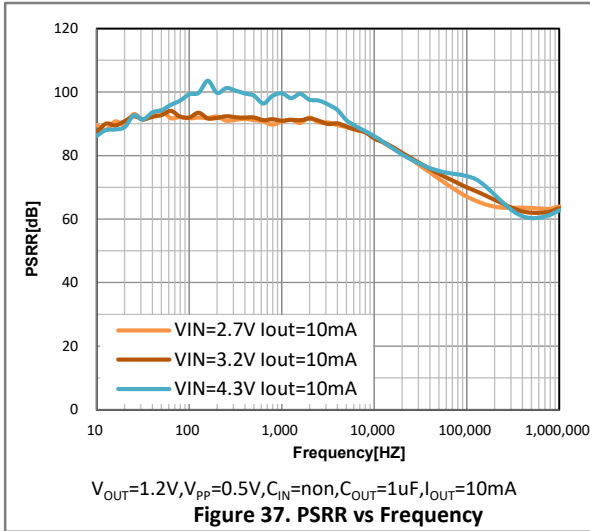

Figure 24. Load Regulation



$C_{IN}=C_{OUT}=1\mu F$





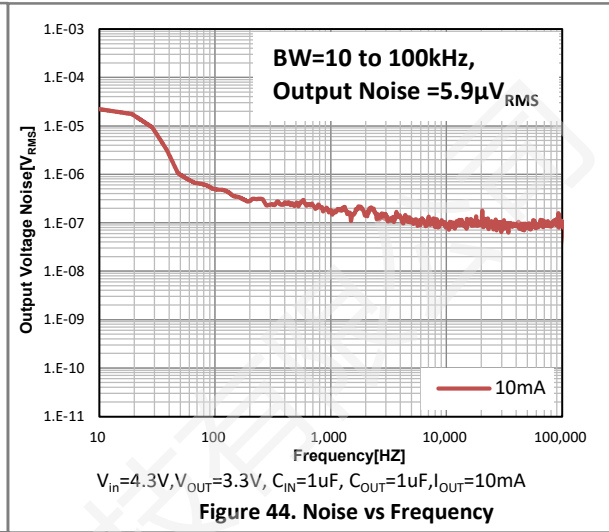
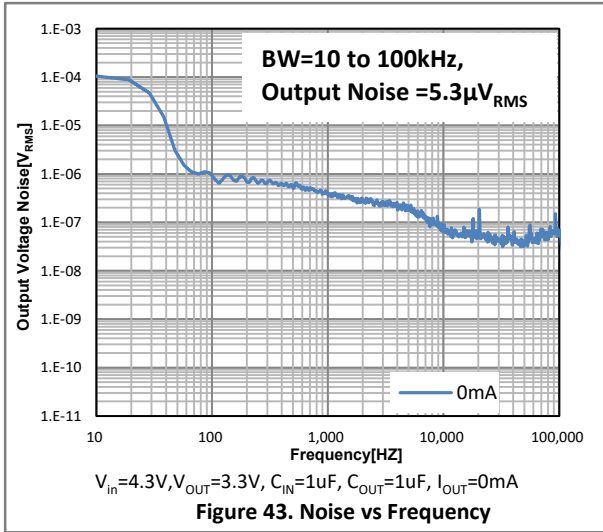

APPLICATION INFORMATION:

- **Input Capacitor Selection**

Like any low-dropout regulator, the external capacitors used with the LW57XX Series must be carefully selected for regulator stability and performance. Using a capacitor whose value is $\geq 1\mu\text{F}$ on the LW57XX Series input and the amount of capacitance can be increased without limit. An at least $10\mu\text{F}$ input capacitor is needed if input ripple voltage $V_{\text{pp}} > 1\text{V}$. The input capacitor must be located a distance less than 0.5 inch from the input pin of the IC and returned to a clean analog ground. Any good quality ceramic or tantalum can be used for this capacitor. The capacitor with larger value and lower ESR (equivalent series resistance) provides better PSRR and line-transient response.

- **Layout considerations**

To improve ac performance such as PSRR, output noise, and transient response, it is recommended that the PCB be designed with separate ground planes for VIN and VOUT, with each ground plane connected only at the GND pin of the device.

- **Output Capacitor Selection**

The output capacitor must meet both requirements for minimum amount of capacitance and ESR in all LDOs application. The LW57XX Series is designed specifically to work with low ESR ceramic output capacitor in space-saving and performance consideration. Using a ceramic capacitor whose value is at least $1\mu\text{F}$ on the LW57XX Series output ensures stability. An appropriate output capacitor can reduce noise and improve load transient response and PSRR. The output capacitor should be located not more than 0.5 inch from the VOUT pin of the LW57XX Series and returned to a clean analog ground.

ORDER INFORMATION:

LW57①②③④⑤⑥

Designator	Item	Symbol	Description
①②	Output Voltage	12~50	e.g.1.2V→①=1,②=2
③④⑤⑥	Packages	A23E	SOT23-5L
		N11E	DFN1x1-4L
		N22G	DFN2x2-6L

Part #	Output Voltage	Package	Shipping
LW5712A23E	1.2V	SOT23-5L	3000 Pcs/ Tape & Reel
LW5715A23E	1.5V		
LW5718A23E	1.8V		
LW5725A23E	2.5V		
LW5728A23E	2.8V		
LW5730A23E	3.0V		
LW5733A23E	3.3V		
LW5736A23E	3.6V		
LW5742A23E	4.2V		
LW5750A23E	5.0V		
LW5712N11E	1.2V	DFN1x1-4L	10000 Pcs/ Tape & Reel
LW5715N11E	1.5V		
LW5718N11E	1.8V		
LW5725N11E	2.5V		
LW5728N11E	2.8V		
LW5730N11E	3.0V		
LW5733N11E	3.3V		
LW5736N11E	3.6V		
LW5742N11E	4.2V		
LW5750N11E	5.0V		

Part #	Output Voltage	Package	Shipping
LW5712N22G	1.2V	DFN2x2-6L	3000 Pcs/ Tape & Reel
LW5715N22G	1.5V		
LW5718N22G	1.8V		
LW5725N22G	2.5V		
LW5728N22G	2.8V		
LW5730N22G	3.0V		
LW5733N22G	3.3V		
LW5736N22G	3.6V		
LW5742N22G	4.2V		
LW5750N22G	5.0V		

If customers have special output voltage requirements, please contact us.

PACKAGE OUTLINE:

SOT23-5L Package

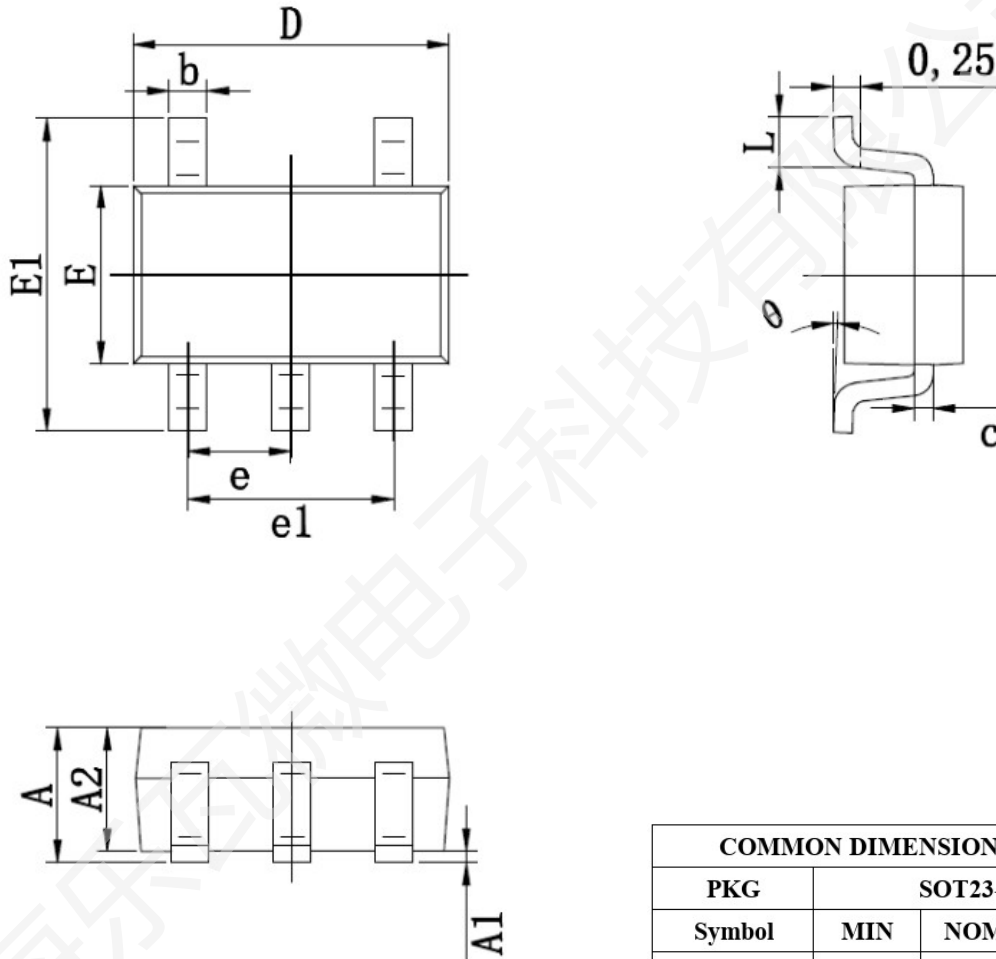

COMMON DIMENSION (MM)			
PKG	SOT23-5L		
Symbol	MIN	NOM	MAX
A	—	—	1.300
A1	0.010	—	0.150
A2	1.050	1.100	1.150
b	0.300	0.350	0.400
c	0.125	0.150	0.175
D	2.870	2.920	2.980
E	1.550	1.610	1.670
E1	2.650	2.850	3.000
e	0.95 BSC		
e1	1.800	1.900	2.000
L	0.300	0.450	0.600
theta	0°	4°	8°

DFN1x1-4L Package

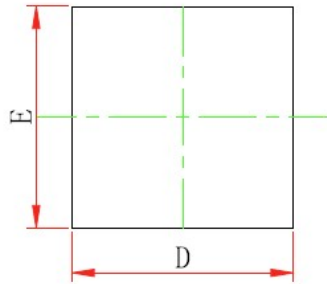

TOP VIEW
[顶视图]

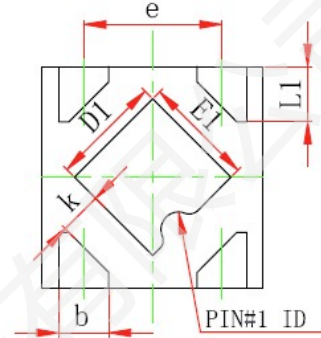

BOTTOM VIEW
[背视图]

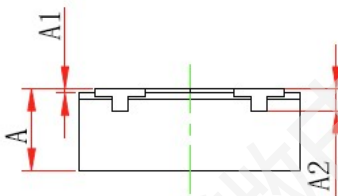

SIDE VIEW
[侧视图]

Symbol	Dimensions In Millimeters		Dimensions In Inches	
	Min.	Max.	Min.	Max.
A	0.335	0.405	0.013	0.016
A1	0.000	0.050	0.000	0.002
A2	0.100REF.		0.004REF.	
D	0.950	1.050	0.037	0.041
E	0.950	1.050	0.037	0.041
D1	0.450	0.550	0.018	0.022
E1	0.450	0.550	0.018	0.022
k	0.195REF.		0.0077REF.	
b	0.175	0.275	0.007	0.011
e	0.575	0.675	0.023	0.027
L1	0.200	0.300	0.008	0.012

DFN2x2-6L Package

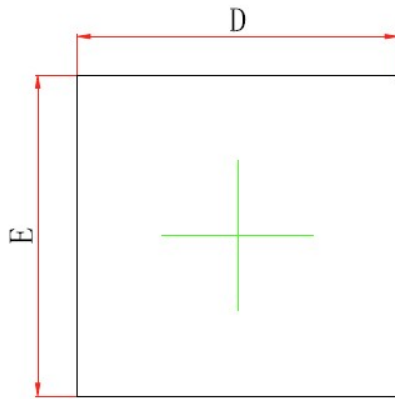

TOP VIEW
[顶视图]

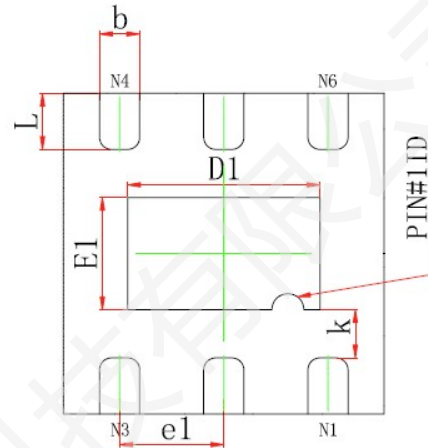

BOTTOM VIEW
[背视图]

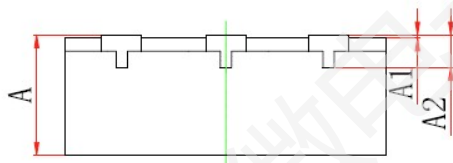

SIDE VIEW
[侧视图]

Symbol	Dimensions In Millimeters		Dimensions In Inches	
	Min.	Max.	Min.	Max.
A	0.700	0.800	0.028	0.031
A1	0.000	0.050	0.000	0.002
A2	0.203REF.		0.008REF.	
D	1.924	2.076	0.076	0.082
E	1.924	2.076	0.076	0.082
D1	1.150	1.250	0.045	0.049
E1	0.650	0.750	0.026	0.030
b	0.200	0.300	0.008	0.012
e1	0.650TYP.		0.026TYP.	
k	0.200MIN.		0.008MIN.	
L	0.300	0.400	0.012	0.016

Revision History:

Revision	Date	Descriptions
Rev 1.0	Aug.2023	Released Version
Rev 1.1	May.2026	Update New Typical Operating Characteristics

DISCLAIMER:

- The product is not intended for use in applications that require extraordinary levels of quality and reliability, such as military, aviation/aerospace and life-support systems or other applications whose failure can be reasonably expected to result in serious physical or material damage.
- Lewa-Micro assumes no responsibility for equipment failures that result from using products at parameters that exceed, even momentarily, rated values (such as maximum ratings, operating condition ranges, or other parameters) listed in products specifications of any Lewa-Micro products described or contained herein.
- Specifications of any and all Lewa-Micro products described or contained herein stipulate the performance, characteristics, and functions of the described products in the independent state, and are not guarantees of the performance, characteristics, and functions of the described products as mounted in the customer's products or equipment. To verify symptoms and states that cannot be evaluated in an independent device, the customer should always evaluate and test devices mounted in the customer's products or equipment.
- Lewa-Micro strives to supply high-quality and high-reliability products. However, any and all semiconductor products have a certain probability of failure. It is possible that these probabilistic failures could give rise to accidents or events that could endanger human lives, that could give rise to smoke or fire, or that could cause damage to other property. When designing equipment, adopt safety measures so that these kinds of accidents or events cannot occur. Such measures including but not limited to protective circuits and error prevention circuits for safe design, redundant design, and structural design.
- To comply with the compliance requirements of relevant export control laws and regulations, if any Lewa-Micro product (including technical data and services) stated herein is subject to relevant export control laws and regulations, it is recommended that the customer apply for and obtain an export license from the competent authority in advance in accordance with the requirements of relevant laws, and do not conduct export activities without obtaining the license. If the customer fails to comply with the aforementioned compliance requirements, all legal liabilities arising therefrom shall be borne solely by the customer.
- To protect Lewa-Micro's intellectual property rights and the security of commercial information, without the prior written permission of Lewa-Micro, no part of this document shall be reproduced or disseminated in any form or by any means (including photocopying, recording, and other electronic or mechanical means, as well as various information storage and retrieval systems). For unauthorized reproduction or dissemination, Lewa-Micro reserves the right to pursue legal liability.
- Information (including circuit diagrams and circuit parameters) herein is for example only; it is not guaranteed for volume production. Lewa-Micro believes information herein is accurate and reliable, but no guarantees are made or implied regarding its use or any infringements of intellectual property rights or other rights of third parties.
- Any and all information described or contained herein are subject to change without notice due to product/technology improvement, etc.

Mailing Address: Unit 02&04&05, 10th Floor, Building 5, No.666 Shengxia Road, No.122 Yindong Road,
China (Shanghai) Pilot Free Trade Zone
Shanghai Lewa Micro-electronics Technology Co., Ltd