

High Precision Operational Amplifiers

Features

- Ultralow Offset Voltage: 10 μ V
- Ultralow Drift: $\pm 0.1 \mu$ V/ $^{\circ}$ C
- High Open-Loop Gain: 134 dB
- High Common-Mode Rejection: 140 dB
- High Power Supply Rejection: 130 dB
- Low Bias Current: 1-nA maximum
- Wide Supply Range: ± 2 V to ± 18 V
- Low Quiescent Current: 1 mA/amplifier
- Single, Dual, and Quad Versions

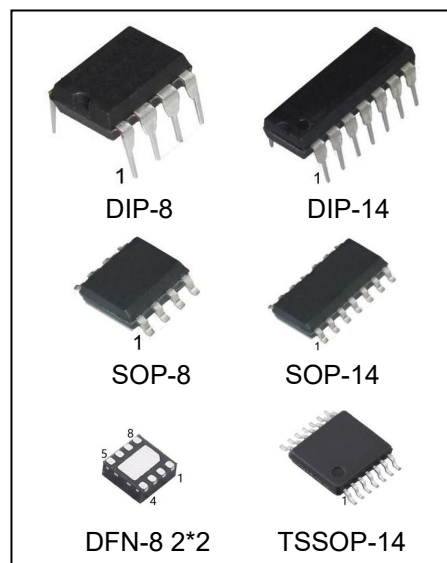

Ordering Information

DEVICE	Package Type	MARKING	Packing	Packing Qty
HG277UN	DIP-8	HG277U	TUBE	2000pcs/box
HG277UAN	DIP-8	HG277UA	TUBE	2000pcs/box
HG277N	DIP-8	HG277	TUBE	2000pcs/box
HG277UM/TR	SOP-8	277U	REEL	2500pcs/reel
HG277UAM/TR	SOP-8	277UA	REEL	2500pcs/reel
HG277M/TR	SOP-8	HG277	REEL	2500pcs/reel
HG277UDQ/TR HG277UDQ2/TR	DFN-8 2*2	277U	REEL	5000pcs/reel*
HG277UADQ/TR HG277UADQ2/TR	DFN-8 2*2	277UA	REEL	5000pcs/reel*
HG277DQ/TR HG277DQ2/TR	DFN-8 2*2	HG277	REEL	5000pcs/reel*
HG2277UN	DIP-8	2277U	TUBE	2000pcs/box
HG2277UAN	DIP-8	2277UA	TUBE	2000pcs/box
HG2277N	DIP-8	HG2277	TUBE	2000pcs/box
HG2277UM/TR	SOP-8	2277U	REEL	2500pcs/reel
HG2277UAM/TR	SOP-8	2277UA	REEL	2500pcs/reel
HG2277M/TR	SOP-8	HG2277	REEL	2500pcs/reel
HG2277UDQ/TR HG2277UDQ2/TR	DFN-8 2*2	HG2277U	REEL	5000pcs/reel*
HG2277UADQ/TR HG2277UADQ2/TR	DFN-8 2*2	2277UA	REEL	5000pcs/reel*
HG2277DQ/TR HG2277DQ2/TR	DFN-8 2*2	HG2277	REEL	5000pcs/reel*
HG4277N	DIP-14	HG4277	TUBE	1000pcs/box
HG4277M/TR	SOP-14	HG4277	REEL	2500pcs/reel
HG4277MT/TR	TSSOP-14	HG4277	REEL	2500pcs/reel

* old: 4000pcs/reel, New packaging quantity of 5000 pcs/reel after December 2025.

Description

The HGx277 series precision operational amplifiers replace the industry standard HGA177. They offer improved noise, wider output voltage swing, and are twice as fast with half the quiescent current. Features include ultralow offset voltage and drift, low bias current, high common-mode rejection, and high power supply rejection. Single, dual, and quad versions have identical specifications, for maximum design flexibility.

HGx277 series operational amplifiers operate from $\pm 2\text{V}$ to $\pm 18\text{V}$ supplies with excellent performance. Unlike most operational amplifiers which are specified at only one supply voltage, the HGx277 series is specified for real-world applications; a single limit applies over the $\pm 5\text{V}$ to $\pm 15\text{V}$ supply range. High performance is maintained as the amplifiers swing to their specified limits. Because the initial offset voltage ($\pm 100\mu\text{V}$ maximum) is so low, user adjustment is usually not required. However, the single version (HG277) provides external trim pins for special applications.

HG277 operational amplifiers are easy to use and free from phase inversion and the overload problems found in some other operational amplifiers. They are stable in unity gain and provide excellent dynamic behavior over a wide range of load conditions. Dual and quad versions feature completely independent circuitry for lowest crosstalk and freedom from interaction, even when overdriven or overloaded.

Applications

- Transducer Amplifiers
- Bridge Amplifiers
- Temperature Measurements
- Strain Gage Amplifiers
- Precision Integrators
- Battery-Powered Instruments
- Test Equipment

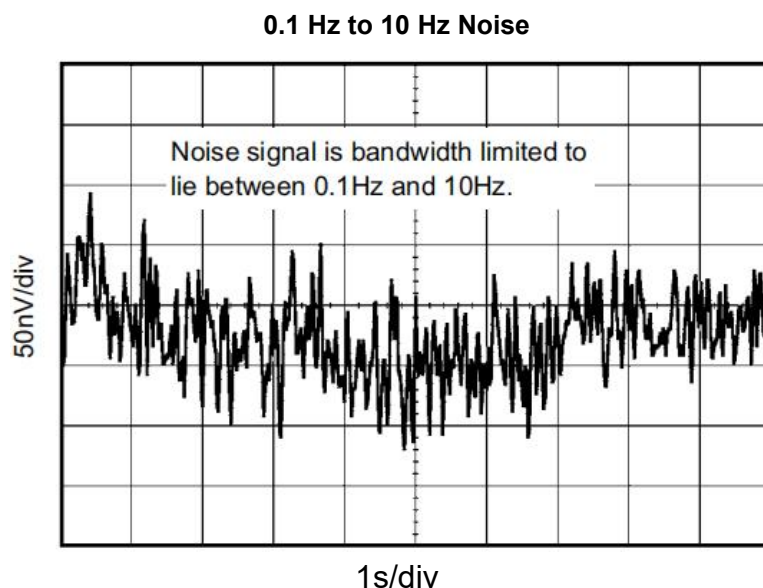

Pin Configuration and Functions

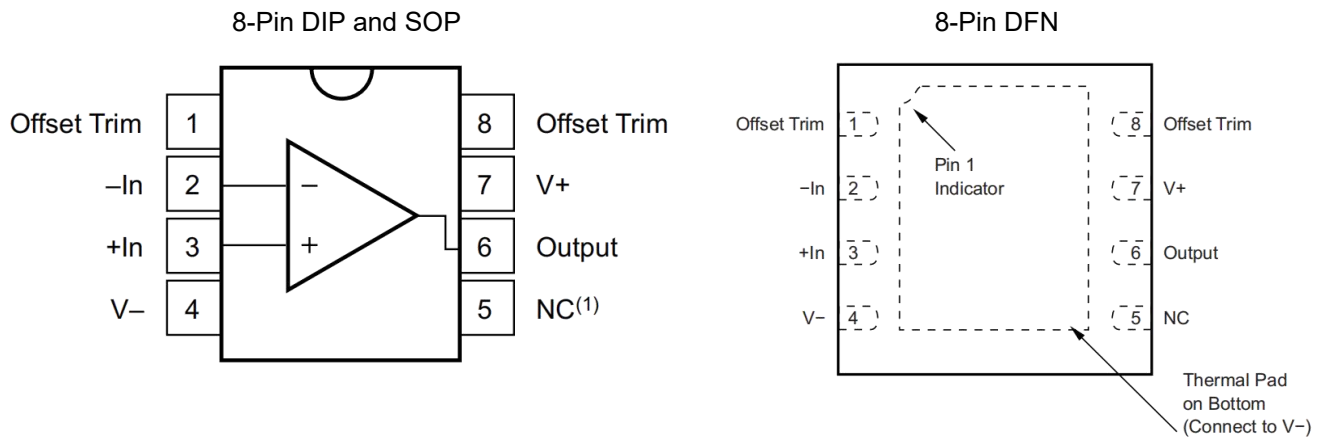

Pin Functions: HG277

NAME	PIN		TYPE	DESCRIPTION
	DIP, SOP NO.	DFN NO.		
Offset Trim	1	1	—	Input offset voltage trim (leave floating if not used)
-In	2	2	Input	Inverting input
+In	3	3	Input	Noninverting input
V-	4	4	—	Negative (lowest) power supply
NC	5	5	—	No internal connection (can be left floating)
Output	6	6	Output	Output
V+	7	7	—	Positive (highest) power supply
Offset Trim	8	8	—	Input offset voltage trim (leave floating if not used)

Pin Configuration and Functions

8-Pin DIP and SOP

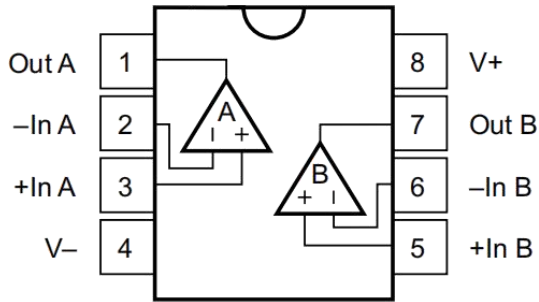

8-Pin DFN

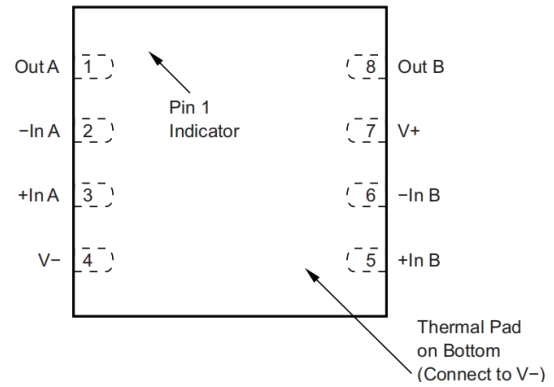

Pin Functions: HG2277

NAME	PIN		I/O	DESCRIPTION
	DIP, SOP NO.	DFN NO.		
Out A	1	1	O	Output channel A
-In A	2	2	I	Inverting input channel A
+In A	3	3	I	Noninverting input channel A
V-	4	4	—	Negative (lowest) power supply
+In B	5	5	I	Noninverting input channel B
-In B	6	6	I	Inverting input channel B
Out B	7	8	O	Output channel B
V+	8	7	—	Positive (highest) power supply

Pin Configuration and Functions

14 Pins DIP, and TSSOP

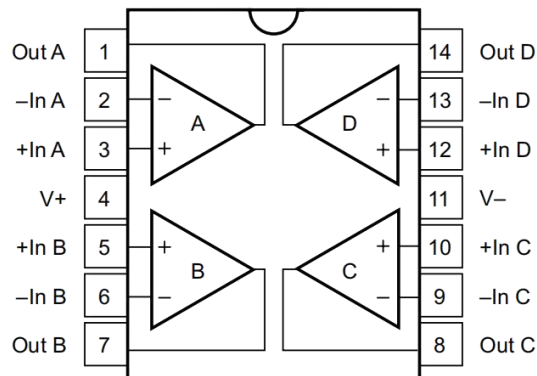

Pin Functions: HG4277

PIN		I/O	DESCRIPTION
NO.	NAME		
1	Out A	O	Output channel A
2	-In A	I	Inverting input channel A
3	+In A	I	Noninverting input channel A
4	V+	—	Positive (highest) power supply
5	+In B	I	Noninverting input channel B
6	-In B	I	Inverting input channel B
7	Out B	O	Output channel B
8	Out C	O	Output channel C
9	-In C	I	Inverting input channel C
10	+In C	I	Noninverting input channel C
11	V-	—	Negative (lowest) power supply
12	+In D	I	Noninverting input channel D
13	-In D	I	Inverting input channel D
14	Out D	O	Output channel D

Specifications

Absolute Maximum Ratings

over operating free-air temperature range (unless otherwise noted)

	MIN	MAX	UNIT
Supply voltage, $V_s = (V+) - (V-)$	-	36	V
Input voltage	(V-) -0.7	(V+) +0.7	V
Output short-circuit ⁽²⁾	Continuous		
Operating temperature	-20	85	°C
Junction temperature	-	150	°C
Lead temperature, 10s	-	260	°C
Storage temperature, T_{stg}	-20	125	°C

- Stresses beyond those listed under Absolute Maximum Ratings may cause permanent damage to the device. These are stress ratings only, which do not imply functional operation of the device at these or any other conditions beyond those indicated under Recommended Operating Conditions. Exposure to absolute-maximum-rated conditions for extended periods may affect device reliability.
- Short-circuit to ground, one amplifier per package.

ESD Ratings

		VALUE	UNIT
$V_{(ESD)}$ Electrostatic discharge	Human-body model (HBM), per ANSI/ESDA/JEDEC JS-001 ⁽¹⁾	±2000	V
	Charged-device model (CDM), per JEDEC specification JESD22-C101 ⁽²⁾	±500	

(1) JEDEC document JEP155 states that 500-V HBM allows safe manufacturing with a standard ESD control process.

(2) JEDEC document JEP157 states that 250-V CDM allows safe manufacturing with a standard ESD control process.

Recommended Operating Conditions

over operating free-air temperature range (unless otherwise noted)

	MIN	NOM	MAX	UNIT
Supply voltage, $V_s = (V+) - (V-)$	4(±2)	30(±15)	36(±18)	V
Specified temperature	-20		+85	°C

Thermal Information for HG277

THERMAL METRIC ⁽¹⁾		HG277			UNIT
		N (DIP)	M (SOP)	DQ(DFN)	
		8 PINS			
$R_{\theta JA}$	Junction-to-ambient thermal resistance	49.2	110.1	40.7	°C/W
$R_{\theta JC(top)}$	Junction-to-case (top) thermal resistance	39.4	52.2	41.3	°C/W
$R_{\theta JB}$	Junction-to-board thermal resistance	26.4	52.3	16.7	°C/W
Ψ_{JT}	Junction-to-top characterization parameter	15.4	10.4	0.6	°C/W
Ψ_{JB}	Junction-to-board characterization parameter	26.3	51.5	16.9	°C/W
$R_{\theta JC(bot)}$	Junction-to-case (bottom) thermal resistance	—	—	3.3	°C/W

- For more information about traditional and new thermal metrics, see the Semiconductor and IC Package Thermal Metrics application report, SPRA953.

Thermal Information for HG2277

THERMAL METRIC ⁽¹⁾	HG2277			UNIT
	N (DIP)	M (SOP)	MT (TSSOP)	
	8 PINS			
R _{θJA} Junction-to-ambient thermal resistance	47.2	107.4	39.3	°C/W
R _{θJC(top)} Junction-to-case (top) thermal resistance	36.0	45.8	36.9	°C/W

- For more information about traditional and new thermal metrics, see the Semiconductor and IC Package Thermal Metrics application report, SPRA953.

Thermal Information for HG2277(continued)

THERMAL METRIC ⁽¹⁾	HG2277			UNIT
	N (DIP)	M (SOP)	DQ (DFN)	
	8 PINS			
R _{θJB} Junction-to-board thermal resistance	24.4	47.9	15.4	°C/W
ψ _{JT} Junction-to-top characterization parameter	13.4	5.7	0.4	°C/W
ψ _{JB} Junction-to-board characterization parameter	24.3	47.3	15.6	°C/W
R _{θJC(bot)} Junction-to-case (bottom) thermal resistance	—	—	2.2	°C/W

Thermal Information for HG4277

THERMAL METRIC ⁽¹⁾	HG4277		UNIT
	N (DIP)	M (SOP)	
	14 PINS		
R _{θJA} Junction-to-ambient thermal resistance	67.0	66.3	°C/W
R _{θJC(top)} Junction-to-case (top) thermal resistance	24.1	20.5	°C/W
R _{θJB} Junction-to-board thermal resistance	22.5	26.8	°C/W
ψ _{JT} Junction-to-top characterization parameter	2.2	2.1	°C/W
ψ _{JB} Junction-to-board characterization parameter	22.1	26.2	°C/W
R _{θJC(bot)} Junction-to-case (bottom) thermal resistance	—	—	°C/W

- For more information about traditional and new thermal metrics, see the Semiconductor and IC Package Thermal Metrics application report, SPRA953.

Electrical Characteristics

At $T_A = 25^\circ\text{C}$, and $R_L = 2\text{ k}\Omega$, unless otherwise noted

PARAMETER		TEST CONDITIONS	HG277U,UA HG2277U,UA			HG277 HG2277 HG4277			UNIT
			MIN	TYP	MAX	MIN	TYP	MAX	
OFFSET VOLTAGE									
V_{OS}	Input Offset Voltage		± 10	± 50		± 100	± 250		μV
Input Offset Voltage Over Temperature	HG277U HG2277U	$T_A = -20^\circ\text{C to } 85^\circ\text{C}$	± 20						μV
	HG277UA HG2277UA		± 20	± 50					
	All Versions					± 250			
dV_{OS}/dT	Input Offset Voltage Drift	$T_A = -20^\circ\text{C to } 85^\circ\text{C}$	HG277U (high-grade, single)						$\mu\text{V}/^\circ\text{C}$
	HG2277U (high-grade, dual)			$\pm 0.1 \quad \pm 0.15$					
	All AIDRM Versions			$\pm 0.1 \quad \pm 0.25$					
Input Offset Voltage: (all models)	vs Time		0.2			See(2)			$\mu\text{V}/\text{mo}$
	vs Power Supply (PSRR)	$V_S = \pm 2\text{ V to } \pm 18\text{ V}$	$\pm 0.3 \quad \pm 0.5$			See(2) ± 1			$\mu\text{V}/\text{V}$
		$T_A = -20^\circ\text{C to } 85^\circ\text{C}$	± 0.5			± 1			
Channel Separation (dual, quad)		DC	0.1			See(2)			$\mu\text{V}/\text{V}$

(1) $V_S = \pm 15\text{ V}$

(2) Specifications are the same as HG277U

Electrical Characteristics (continued)

 At $T_A = 25^\circ\text{C}$, and $R_L = 2\text{ k}\Omega$, unless otherwise noted

PARAMETER		TEST CONDITIONS	HG277U,UA HG2277U,UA			HG277 HG2277 HG4277			UNIT
			MIN	TYP	MAX	MIN	TYP	MAX	
INPUT BIAS CURRENT									
I_B	Input Bias Current	$T_A = -20^\circ\text{C}$ to 85°C	± 0.5	± 1		See (2)	± 2.8	nA	
				± 2			± 4		
I_{OS}	Input Offset Current	$T_A = -20^\circ\text{C}$ to 85°C	± 0.5	± 1		See (2)	± 2.8	nA	
				± 2			± 4		
NOISE									
Input Voltage Noise, $f = 0.1$ to 10 Hz			0.22			See (2)		μV_{PP}	
Input Voltage Noise Density	$f = 10\text{ Hz}$		12			See (2)		nV/ $\sqrt{\text{Hz}}$	
	$f = 100\text{ Hz}$		8			See (2)			
	$f = 1\text{ kHz}$		8			See (2)			
	$f = 10\text{ kHz}$		8			See (2)			
I_n	Current Noise Density, $f = 1\text{ kHz}$		0.2			See (2)		pA/ $\sqrt{\text{Hz}}$	
INPUT VOLTAGE RANGE									
V_{CM}	Common-Mode Voltage Range		(V $-$)+2	(V $+$)-2		See (2)	See (2)	V	
CMRR	Common-Mode Rejection	$V_{CM} = (V-) + 2\text{ V to } (V+) - 2\text{ V}$	130	140		115	See (2)	dB	
		$T_A = -20^\circ\text{C}$ to 85°C	128			115			
INPUT IMPEDANCE									
Differential			100 3			See (2)		M Ω pF	
Common-Mode		$V_{CM} = (V-) + 2\text{ V to } (V+) - 2\text{ V}$	250 3			See (2)		G Ω pF	
OPEN-LOOP GAIN									
A_{OL}	Open-Loop Voltage Gain	$V_O = (V-) + 0.5\text{ V to } (V+) - 1.2\text{ V}, R_L = 10\text{ k}\Omega$	140			See (2)		dB	
		$V_O = (V-) + 1.5\text{ V to } (V+) - 1.5\text{ V}, R_L = 2\text{ k}\Omega$	126	134		See (2)	See (2)		
		$V_O = (V-) + 1.5\text{ V to } (V+) - 1.5\text{ V}, R_L = 2\text{ k}\Omega$	126			See (2)		dB	
		$T_A = -20^\circ\text{C}$ to 85°C							
FREQUENCY RESPONSE									
GBW	Gain-Bandwidth Product		1			See (2)		MHz	
SR	Slew Rate		0.8			See (2)		V/ μs	
Settling Time	0.1%	$V_S = \pm 15\text{ V}, G = 1,$ 10-V Step	14			See (2)		μs	
	0.01%		16			See (2)			
Overload Recovery Time		$V_{IN} \times G = V_S$	3			See (2)		μs	
THD+N	Total Harmonic Distortion+Noise	1 kHz, $G = 1,$ $V_O = 3.5\text{ V}_{rms}$	0.002%			See (2)			

Electrical Characteristics (continued)

 At $T_A = 25^\circ\text{C}$, and $R_L = 2\text{ k}\Omega$, unless otherwise noted

PARAMETER	TEST CONDITIONS	HG277U,UA HG2277U,UA			HG277 HG2277 HG4277			UNIT
		MIN	TYP(1)	MAX	MIN	TYP	MAX	
OUTPUT								
V_O Voltage Output	$R_L = 10\text{ k}\Omega$	(V-)+2		(V+)-2	See(2)		See(2)	V
	$T_A = -20^\circ\text{C}$ to $+85^\circ\text{C}$	(V-)+2		(V+)-2	See(2)		See(2)	
	$R_L = 2\text{ k}\Omega$	(V-)+3		(V+)-3	See(2)		See(2)	
	$T_A = -20^\circ\text{C}$ to $+85^\circ\text{C}$	(V-)+3		(V+)-3	See(2)		See(2)	
I_{SC} Short-Circuit Current		± 35			See (2)			mA
C_{LOAD} Capacitive Load Drive		See (3)						
Z_O Open-loop output impedance	$f = 1\text{ MHz}$	40			See (2)			Ω
POWER SUPPLY								
V_S Specified Voltage Range		± 5		± 15	See(2)		See(2)	V
Operating Voltage Range		± 2		± 18	See(2)		See(2)	V
I_Q Quiescent Current (per amplifier)	$I_o = 0$			± 3.5			See(2)	mA
	$T_A = -20^\circ\text{C}$ to 85°C	± 1			See(2)			
TEMPERATURE RANGE								
Specified Range		-20		85	See(2)		See(2)	$^\circ\text{C}$
Operating Range		-20		125	See(2)		See(2)	$^\circ\text{C}$

(3) See Typical Characteristics

Typical Characteristics

At TA = 25°C, VS = ±15 V, and RL = 2 kΩ, unless otherwise noted.

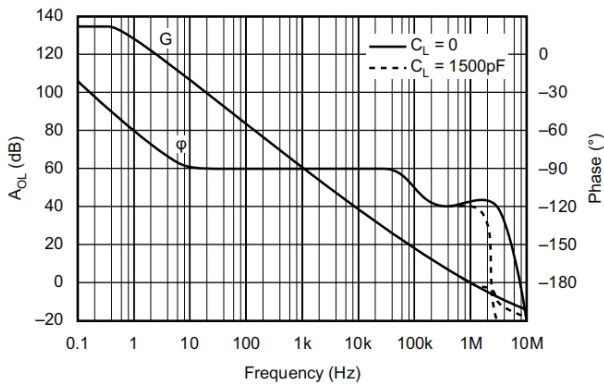

Figure 1. Open-Loop Gain and Phase vs Frequency

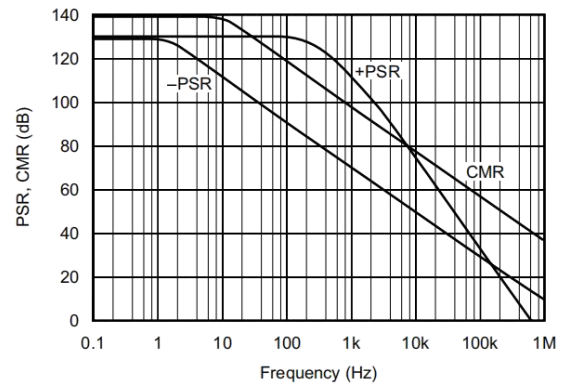

Figure 2. Power Supply and Common-Mod Rejection vs Frequency

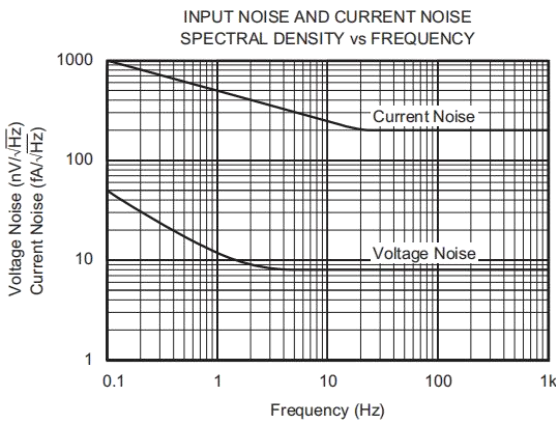

Figure 3. Input Noise and Current Noise Spectral Density vs Frequency

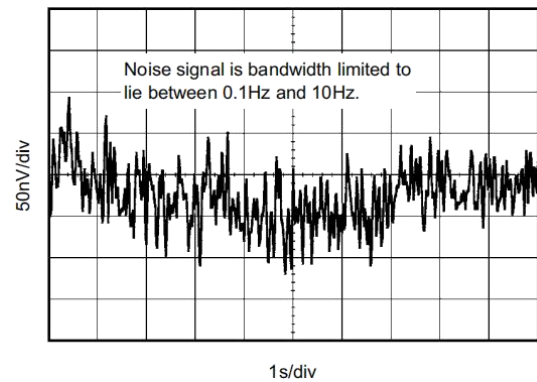

Figure 4. Input Noise Voltage vs Time

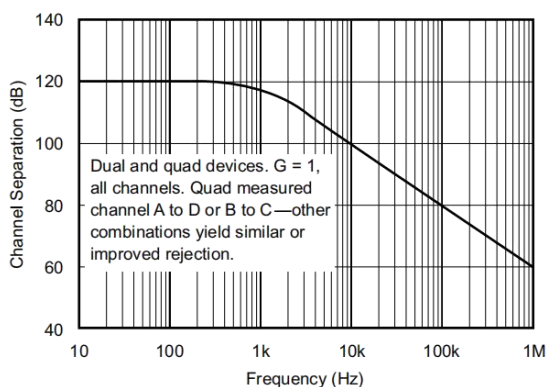

Figure 5. Channel Separation vs Frequency

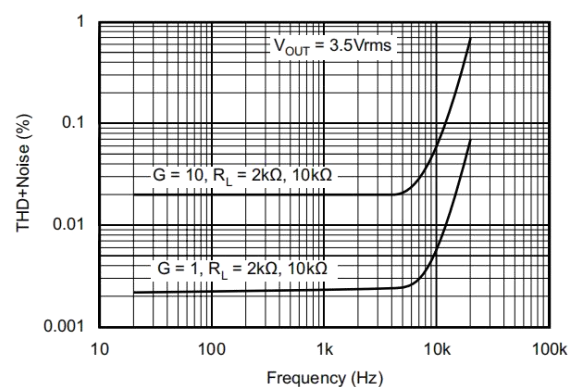

Figure 6. Total Harmonic Distortion + Noise vs Frequency

Typical Characteristics (continued)

At $T_A = 25^\circ\text{C}$, $V_S = \pm 15\text{ V}$, and $R_L = 2\text{ k}\Omega$, unless otherwise noted.

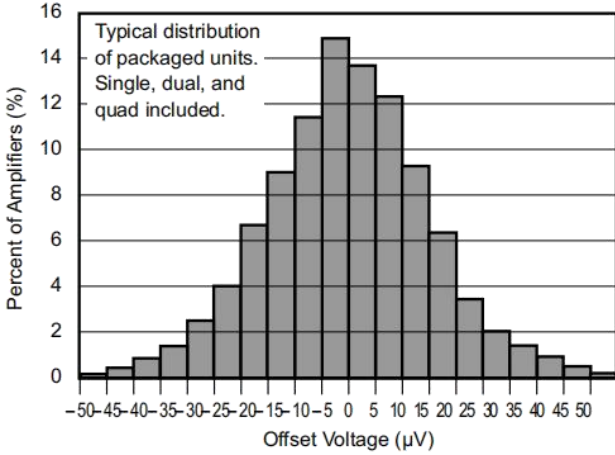

Figure 7. Offset Voltage Production Distribution

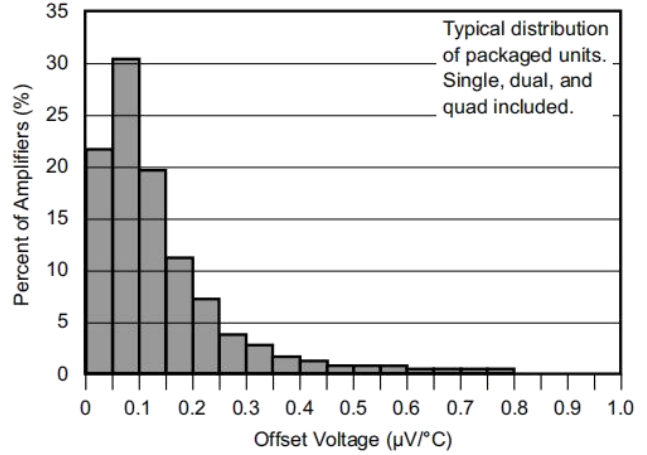

Figure 8. Offset Voltage Drift Production Distribution

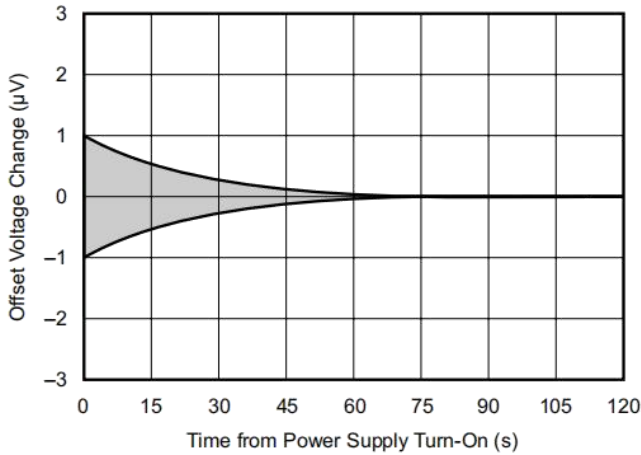

Figure 9. Warm-Up Offset Voltage Drift

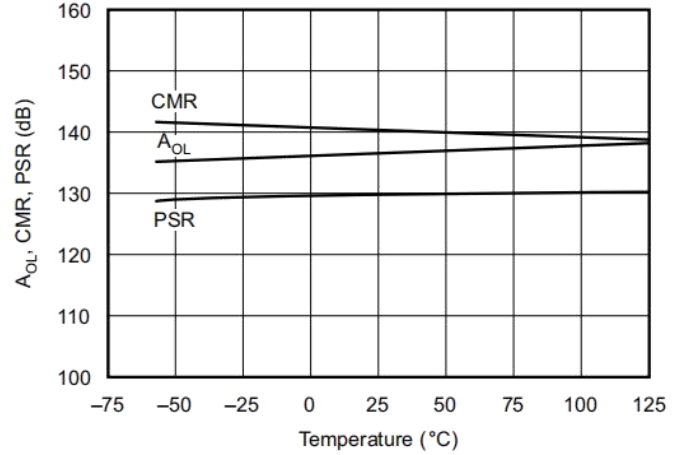

Figure 10. AOL, CMR, PSR vs Temperature

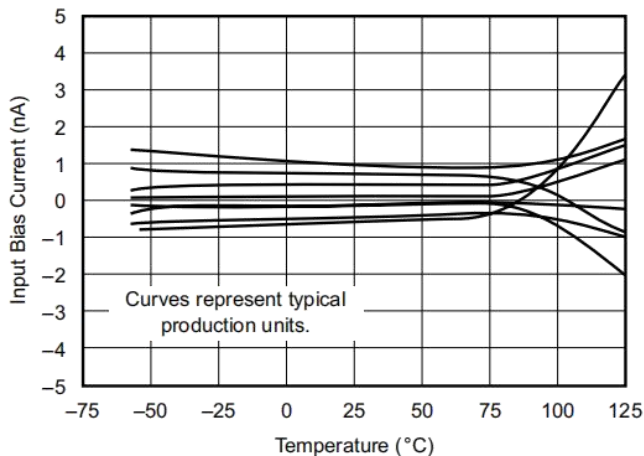

Figure 11. Input Bias Current vs Temperature

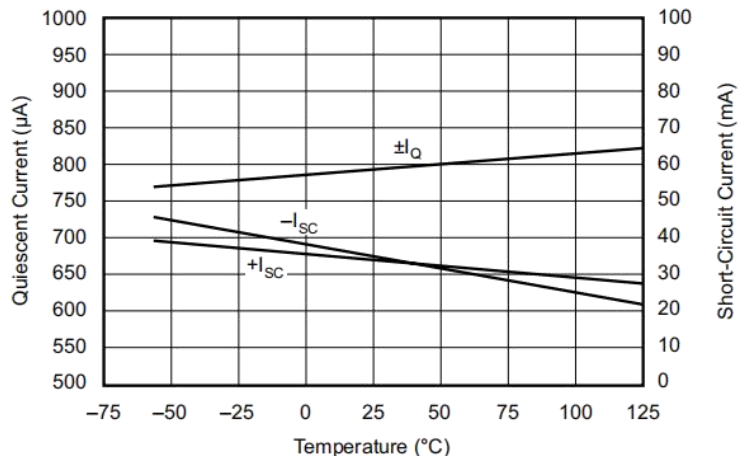

Figure 12. Quiescent Current and Short-Circuit Current vs Temperature

Typical Characteristics (continued)

At TA = 25°C, VS = ±15 V, and RL = 2 kΩ, unless otherwise noted.

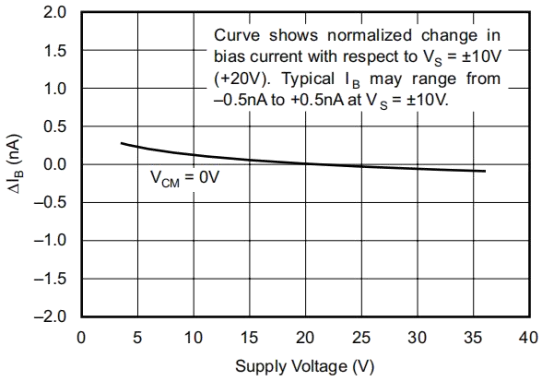

Figure 13. Change in Input Bias Current vs Power Supply Voltage

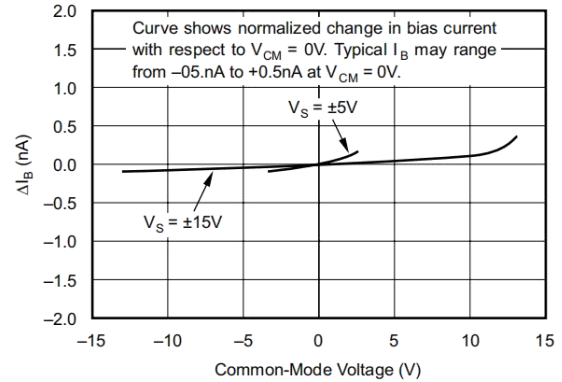

Figure 14. Change in Input Bias Current vs Common-Mode Voltage

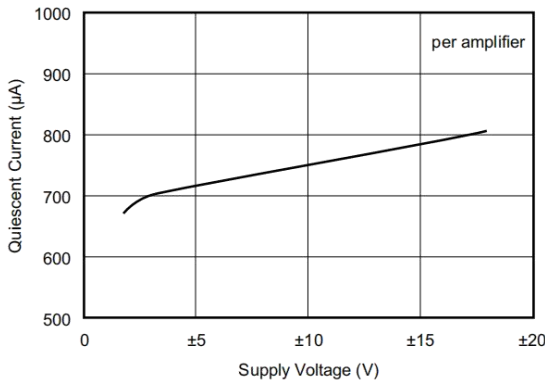

Figure 15. Quiescent Current vs Supply Voltage

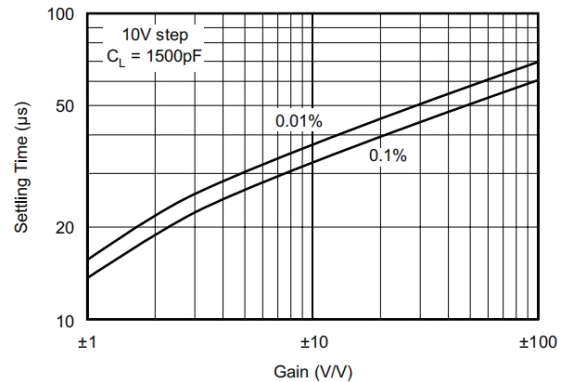

Figure 16. Settling Time vs Closed-Loop Gain

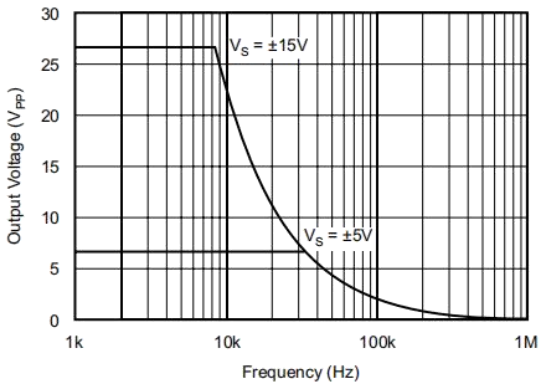

Figure 17. Maximum Output Voltage vs Frequency

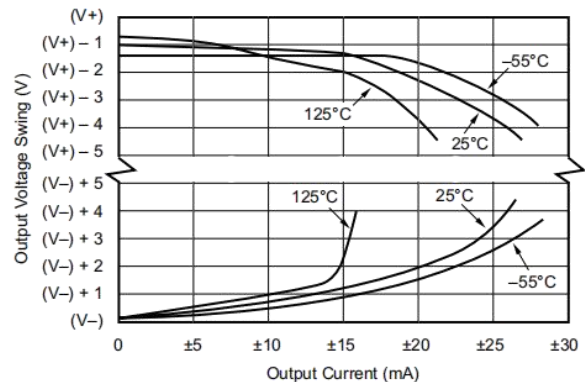

Figure 18. Output Voltage Swing vs Output Current

Typical Characteristics (continued)

At TA = 25°C, VS = ±15 V, and RL = 2 kΩ, unless otherwise noted.

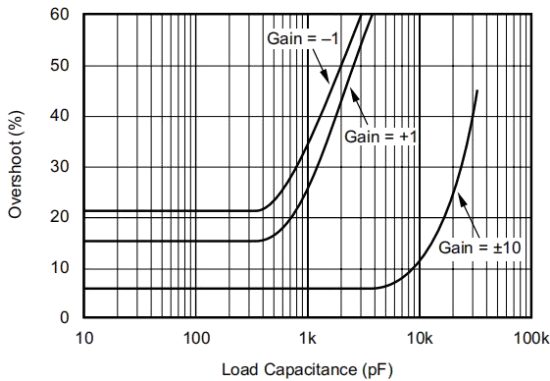

Figure 19. Small-Signal Overshoot vs Load Capacitance

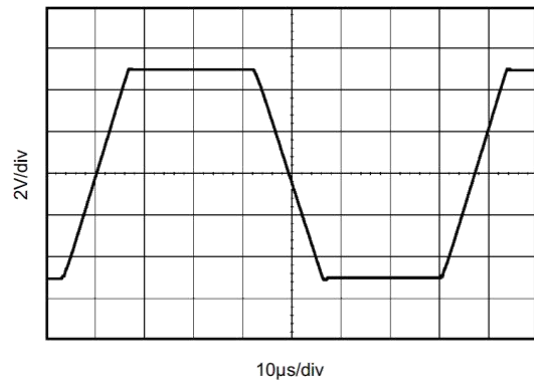

Figure 20. Large-Signal Step Response
G = 1, CL = 1500 pF, VS = ±15 V

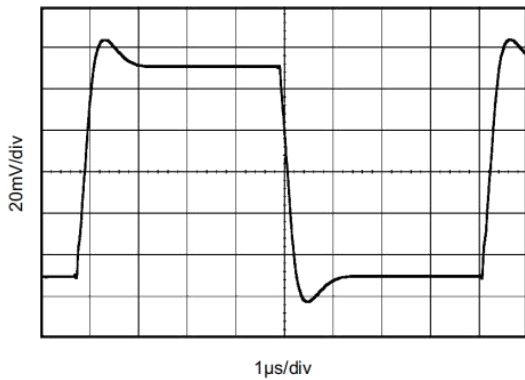

Figure 21. Small-Signal Step Response
G = +1, CL = 0, VS = ±15 V

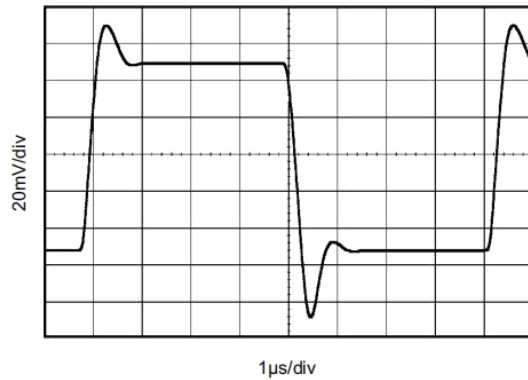

Figure 22. Small-Signal Step Response
G = 1, CL = 1500 pF, VS = ±15 V

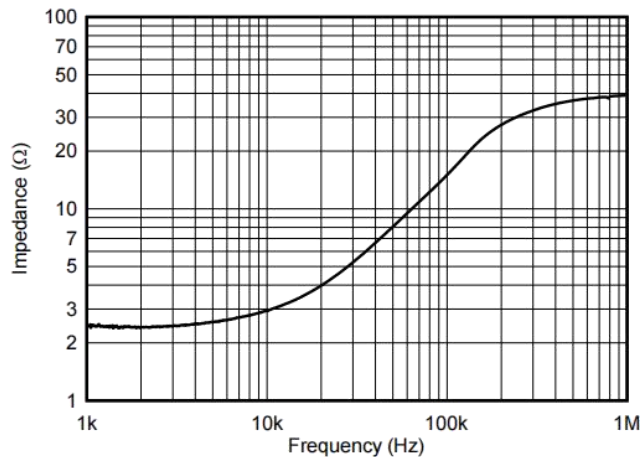

Figure 23. Open-Loop Output Impedance VS = ±15 V

Detailed Description

Overview

The HGx277 series precision operational amplifiers replace the industry standard HGA177. They offer improved noise, wider output voltage swing, and are twice as fast with half the quiescent current. Features include ultralow offset voltage and drift, low bias current, high common-mode rejection, and high power supply rejection. Single, dual, and quad versions have identical specifications, for maximum design flexibility.

Functional Block Diagram

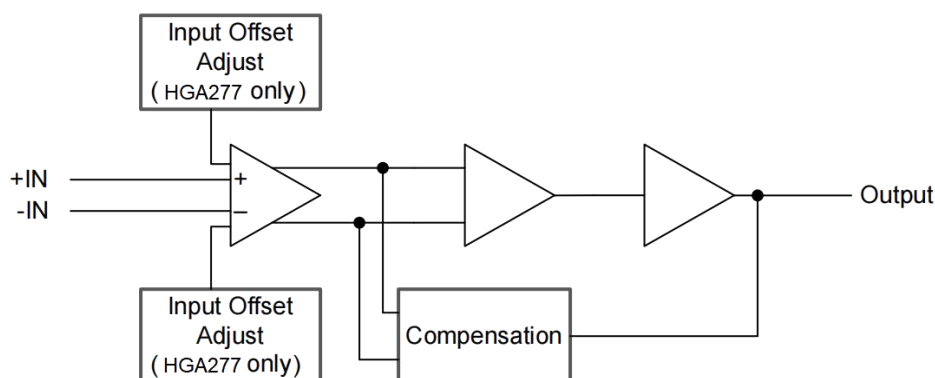

Feature Description

The HGx277 series is unity-gain stable and free from unexpected output phase reversal, making it easy to use in a wide range of applications. Applications with noisy or high-impedance power supplies may require decoupling capacitors close to the device pins. In most cases 0.1- μ F capacitors are adequate.

The HGx277 series has low offset voltage and drift. To achieve highest performance, the circuit layout and mechanical conditions should be optimized. Offset voltage and drift can be degraded by small thermoelectric potentials at the operational amplifier inputs. Connections of dissimilar metals generate thermal potential, which can degrade the ultimate performance of the HGx277 series. These thermal potentials can be made to cancel by assuring that they are equal in both input terminals.

- Keep the thermal mass of the connections to the two input terminals similar
- Locate heat sources as far as possible from the critical input circuitry
- Shield operational amplifier and input circuitry from air currents, such as cooling fans

Operating Voltage

HGx277 series operational amplifiers operate from ± 2 -V to ± 18 -V supplies with excellent performance. Unlike most operational amplifiers, which are specified at only one supply voltage, the HG277 series is specified for real-world applications; a single limit applies over the ± 5 -V to ± 15 -V supply range. This allows a customer operating at $V_S = \pm 10$ V to have the same assured performance as a customer using ± 15 -V supplies. In addition, key parameters are assured over the specified temperature range, -20°C to 85°C . Most behavior remains unchanged through the full operating voltage range (± 2 V to ± 18 V). Parameters which vary significantly with operating voltage or temperature are shown in Typical Characteristics.

Offset Voltage Adjustment

The HGx277 series is laser-trimmed for low offset voltage and drift, so most circuits do not require external adjustment. However, offset voltage trim connections are provided on pins 1 and 8. Offset voltage can be adjusted by connecting a potentiometer, as shown in Figure 24. Only use this adjustment to null the offset of the operational amplifier. This adjustment should not be used to compensate for offsets created elsewhere in a system, because this can introduce additional temperature drift.

Feature Description (continued)

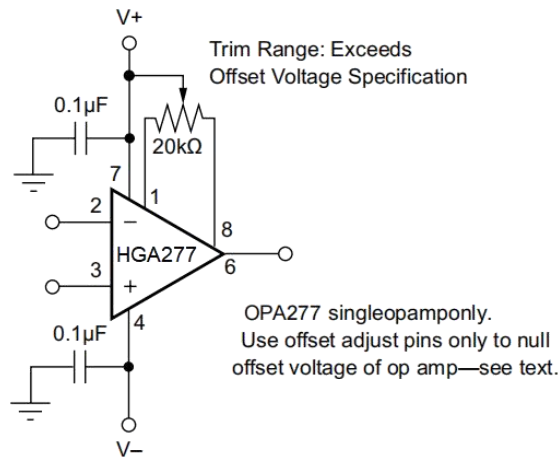

Figure 24. HG277 Offset Voltage Trim Circuit

Input Protection

The inputs of the HGx277series are protected with 1-kΩ series input resistors and diode clamps. The inputs can withstand ±30-V differential inputs without damage. The protection diodes conduct current when the inputs are over-driven. This may disturb the slewing behavior of unity-gain follower applications, but will not damage the operational amplifier.

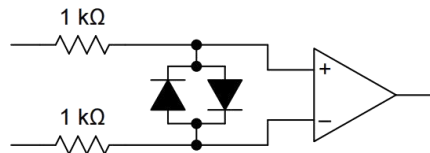

Figure 25. HGx277Input Protection

Input Bias Current Cancellation

The input stage base current of the HGA x277series is internally compensated with an equal and opposite cancellation circuit. The resulting input bias current is the difference between the input stage base current and the cancellation current. This residual input bias current can be positive or negative.

When the bias current is canceled in this manner, the input bias current and input offset current are approximately the same magnitude. As a result, it is not necessary to use a bias current cancellation resistor, as is often done with other operational amplifiers (see Figure 26). A resistor added to cancel input bias current errors may actually increase offset voltage and noise.

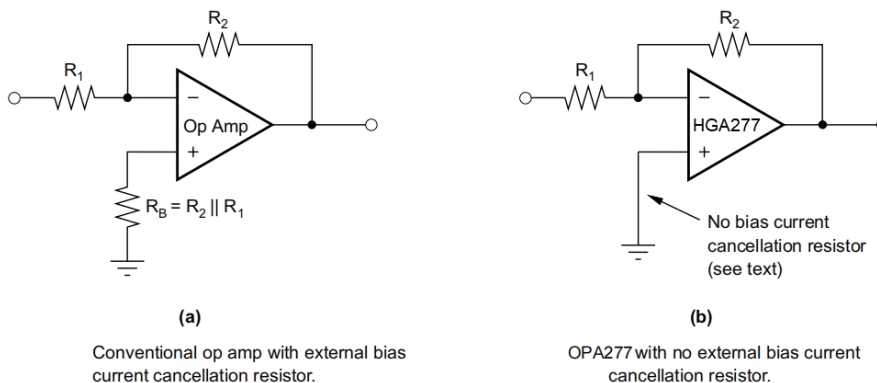

Figure 26. Input Bias Current Cancellation

EMI Rejection Ratio (EMIRR)

The electromagnetic interference (EMI) rejection ratio, or EMIRR, describes the EMI immunity of operational amplifiers. An adverse effect that is common to many operational amplifiers is a change in the offset voltage as a result of RF signal rectification. An operational amplifier that is more efficient at rejecting this change in offset as a result of EMI has a higher EMIRR and is quantified by a decibel value. Measuring EMIRR can be performed in many ways, but this report provides the EMIRR IN+, which specifically describes the EMIRR performance when the RF signal is applied to the noninverting input pin of the operational amplifier. In general, only the noninverting input is tested for EMIRR for the following three reasons:

1. Operational amplifier input pins are known to be the most sensitive to EMI, and typically rectify RF signals better than the supply or output pins.
2. The noninverting and inverting operational amplifier inputs have symmetrical physical layouts and exhibit nearly matching EMIRR performance.
3. EMIRR is easier to measure on noninverting pins than on other pins because the noninverting input terminal can be isolated on a printed circuit board (PCB). This isolation allows the RF signal to be applied directly to the noninverting input terminal with no complex interactions from other components or connecting PCB traces.

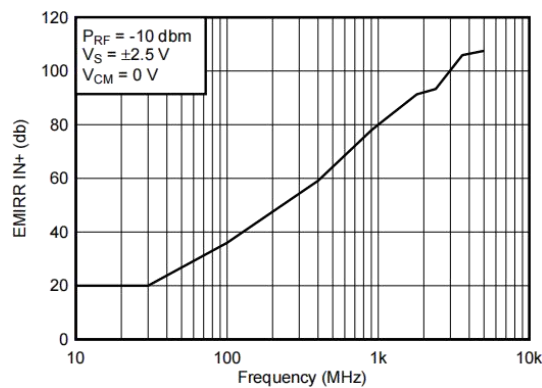

Figure 27. HG277 EMIRR IN+ vs Frequency

If available, any dual and quad operational amplifier device versions have nearly similar EMIRR IN+ performance. The HG277 unity-gain bandwidth is 1 MHz. EMIRR performance below this frequency denotes interfering signals that fall within the operational amplifier bandwidth.

Feature Description (continued)

Table 1 shows the EMIRR IN+ values for the HG277 at particular frequencies commonly encountered in real world applications. Applications listed in Table 1 may be centered on or operated near the particular frequency shown. This information may be of special interest to designers working with these types of applications, or working in other fields likely to encounter RF interference from broad sources, such as the industrial, scientific, and medical (ISM) radio band.

Table 1. HG277 EMIRR IN+ for Frequencies of Interest

FREQUENCY	APPLICATION/ALLOCATION	EMIRR IN+
400 MHz	Mobile radio, mobile satellite/space operation, weather, radar, UHF	59.1 dB
900 MHz	GSM, radio com/nav./GPS (to 1.6 GHz), ISM, aeronautical mobile, UHF	77.9 dB
1.8 GHz	GSM, mobile personal comm. broadband, satellite, L-band	91.3 dB
2.4 GHz	802.11b/g/n, Bluetooth™, mobile personal comm., ISM, amateur radio/satellite, S-band	93.3 dB
3.6 GHz	Radiolocation, aero comm./nav., satellite, mobile, S-band	105.9 dB
5.0 GHz	802.11a/n, aero comm./nav., mobile comm., space/satellite operation, C-band	107.5 dB

EMIRR IN+ Test Configuration

Figure 28 shows the circuit configuration for testing the EMIRR IN+. An RF source is connected to the operational amplifier noninverting input terminal using a transmission line. The operational amplifier is configured in a unity gain buffer topology with the output connected to a low-pass filter (LPF) and a digital multimeter (DMM). Note that a large impedance mismatch at the operational amplifier input causes a voltage reflection; however, this effect is characterized and accounted for when determining the EMIRR IN+. The resulting dc offset voltage is sampled and measured by the multimeter. The LPF isolates the multimeter from residual RF signals that may interfere with multimeter accuracy. Refer to SBOA128 for more details.

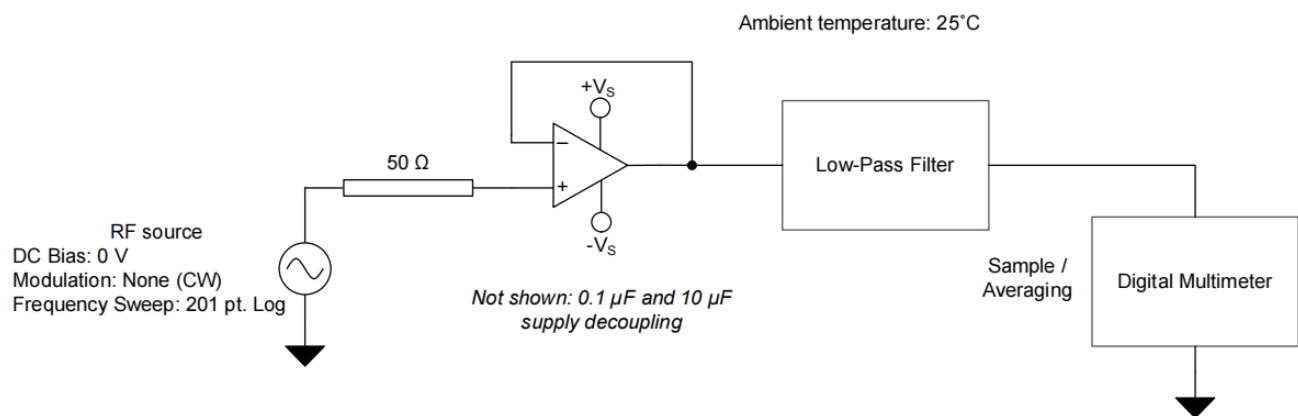

Figure 28. EMIRR IN+ Test Configuration Schematic

Device Functional Modes

The HGx277 has a single functional mode and is operational when the power-supply voltage is greater than 4V (± 2 V). The maximum power supply voltage for the HGx277 is 36 V (± 18 V).

Physical Dimensions

SOP-8

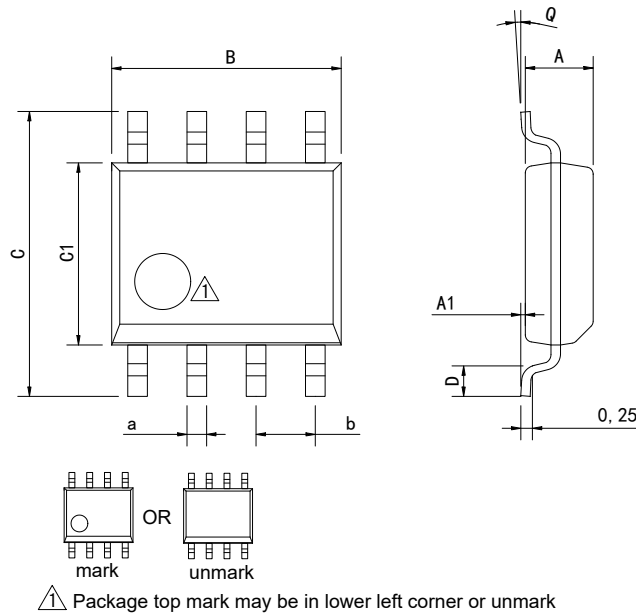

Dimensions In Millimeters(SOP-8)									
Symbol:	A	A1	B	C	C1	D	Q	a	b
Min:	1.35	0.05	4.90	5.80	3.80	0.40	0°	0.35	1.27 BSC
Max:	1.55	0.20	5.10	6.20	4.00	0.80	8°	0.45	

DIP-8

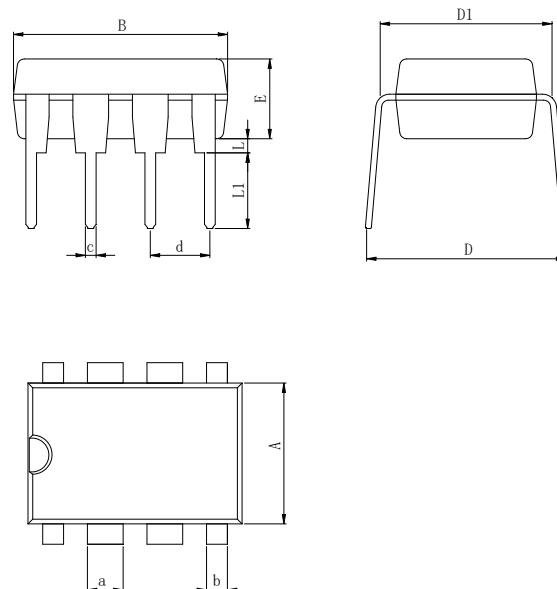

Dimensions In Millimeters(DIP-8)											
Symbol:	A	B	D	D1	E	L	L1	a	b	c	d
Min:	6.10	9.00	8.10	7.42	3.10	0.50	3.00	1.50	0.85	0.40	2.54 BSC
Max:	6.68	9.50	10.9	7.82	3.55	0.70	3.60	1.55	0.90	0.50	

Physical Dimensions

SOP-14

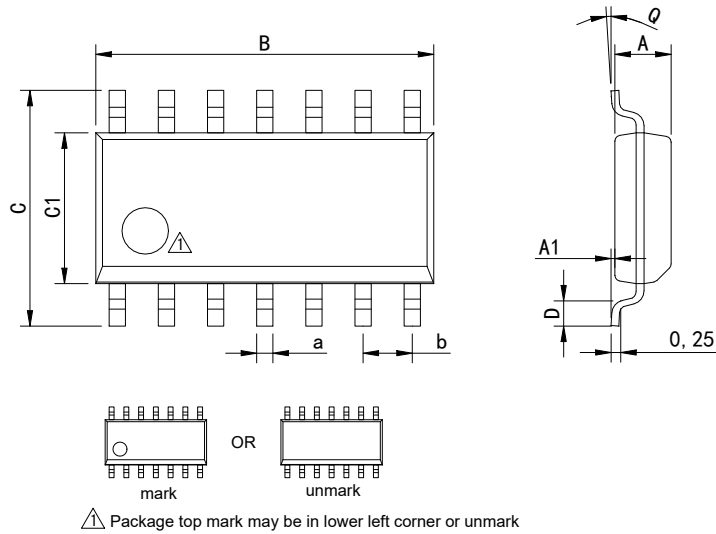

Dimensions In Millimeters(SOP-14)									
Symbol:	A	A1	B	C	C1	D	Q	a	b
Min:	1.35	0.05	8.55	5.80	3.80	0.40	0°	0.35	1.27 BSC
Max:	1.55	0.20	8.75	6.20	4.00	0.80	8°	0.45	

DIP-14

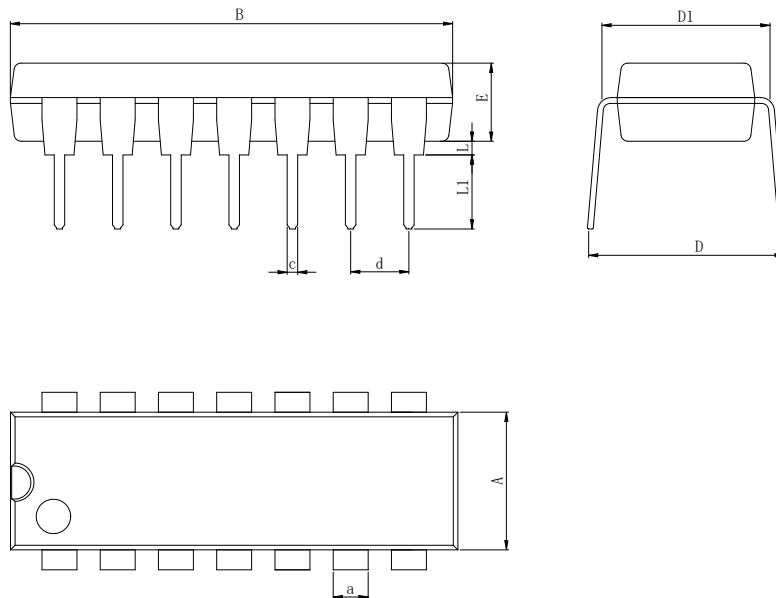

Dimensions In Millimeters(DIP-14)										
Symbol:	A	B	D	D1	E	L	L1	a	c	d
Min:	6.10	18.94	8.10	7.42	3.10	0.50	3.00	1.50	0.40	2.54 BSC
Max:	6.68	19.56	10.9	7.82	3.55	0.70	3.60	1.55	0.50	

Physical Dimensions

DFN-8 2*2

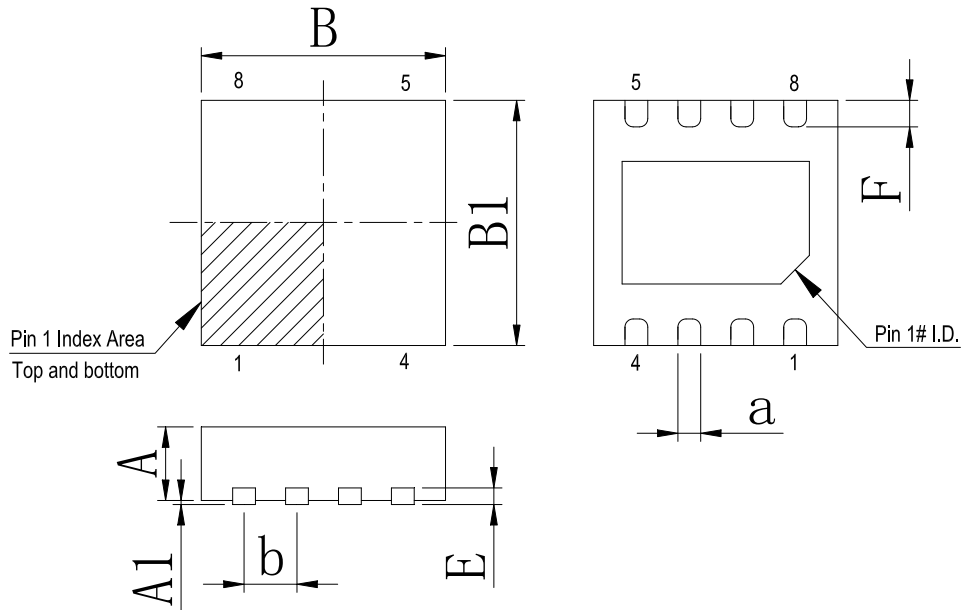

Dimensions In Millimeters(DFN-8 2*2)

Symbol:	A	A1	B	B1	E	F	a	b
Min:	0.85	0	1.90	1.90	0.15	0.25	0.18	0.50TYP
Max:	0.95	0.05	2.10	2.10	0.25	0.45	0.30	

TSSOP-14

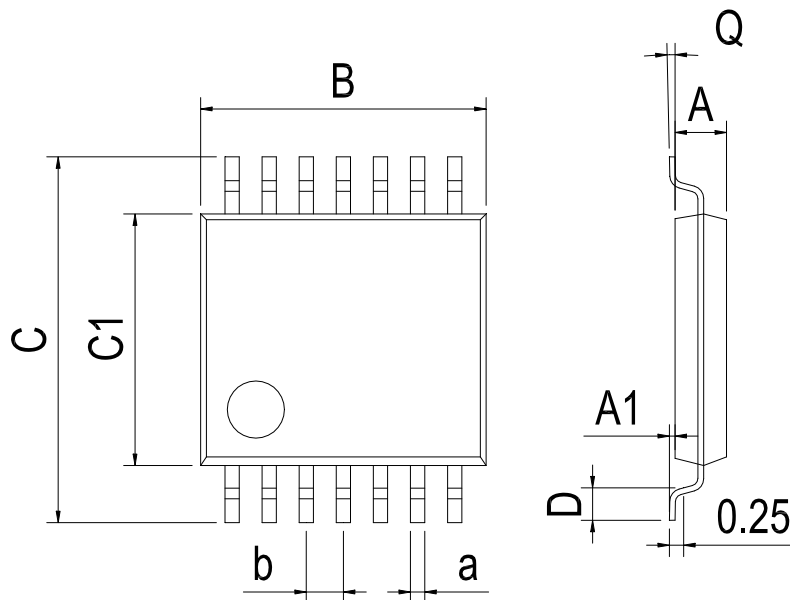

Dimensions In Millimeters(TSSOP-14)

Symbol:	A	A1	B	C	C1	D	Q	a	b
Min:	0.85	0.05	4.90	6.20	4.30	0.40	0°	0.20	0.65 BSC
Max:	0.95	0.20	5.10	6.60	4.50	0.80	8°	0.25	

Revision History

REVISION NUMBER	DATE	REVISION	PAGE
V1.0	2017-8	New	1-23
V1.1	2021-8	Update encapsulation type、 Update DIP-8 dimension	1、 19
V1.2	2024-11	Update Supply voltage range is $\pm 16V$ 、 Update Lead Temperature	6
V1.3	2025-6	Update the voltage output value and Quiescent Current value.	10
V1.4	2025-8	Change the maximum value of static current from 2.5mA to 3.5mA	10
V1.5	2025-11	Update important statements 、 Update SOP-8 and SOP-14 Dimension drawing	19、 20、 23

IMPORTANT STATEMENT:

Huaguan Semiconductor reserves the right to change products and services offered without prior notice. Customers should obtain the latest relevant information before placing orders and verify that such information is current and complete. Huaguan Semiconductor assumes no responsibility or liability for altered documents.

Customers are responsible for complying with safety standards and implementing safety measures when using Huaguan Semiconductor products in system design and end-product manufacturing. You assume full responsibility for: selecting the appropriate Huaguan Semiconductor products for your application; designing, validating, and testing your application; and ensuring that your application complies with applicable standards and all other safety, security, or other requirements. This is to prevent potential risks that may lead to personal injury or property damage.

Huaguan Semiconductor products are not approved for use in life support, military, aerospace, or other high-risk applications. Huaguan products are neither intended nor warranted for use in such systems or equipment. Any failure or malfunction may lead to personal injury or severe property damage. Such applications are deemed "Unsafe Use." Unsafe Use includes, but is not limited to: surgical and medical equipment, nuclear energy control equipment, aircraft or spacecraft instruments, control or operation of vehicle power, braking, or safety systems, traffic signal instruments, all types of safety devices, and any other applications intended to support or sustain life. Huaguan Semiconductor shall not be liable for consequences resulting from Unsafe Use in these fields. Users must independently evaluate and assume all risks. Any issues, liabilities, or losses arising from the use of products beyond their approved applications shall be solely borne by the user. Users may not claim any compensation from Huaguan Semiconductor based on these terms. If any third party claims against Huaguan Semiconductor due to such Unsafe Use, the user shall compensate Huaguan Semiconductor for all resulting damages and liabilities.

Huaguan Semiconductor provides technical and reliability data (including datasheets), design resources (including reference designs), application or other design advice, web tools, safety information, and other resources for its semiconductor products. However, no guarantee is made that these resources are free from defects, and no express or implied warranties are provided. The use of testing and other quality control techniques is limited to Huaguan Semiconductor's quality assurance scope. Not all parameters of each device are tested.

Huaguan Semiconductor's documentation authorizes you to use these resources only for developing applications related to the products described herein. You are not granted rights to any other intellectual property of Huaguan Semiconductor or any third party. Any other reproduction or display of these resources is strictly prohibited. You shall fully indemnify Huaguan Semiconductor and its agents against any claims, damages, costs, losses, and liabilities arising from your use of these resources. Huaguan Semiconductor shall not be held responsible.