

由 Autodesk 教育版产品制作

修订	标记	修改摘要	签名	日期
REV	MARK	REVISION DESCRIPTION	SIGNATURE	DATE
AO		NEW DRG		2016-03-12

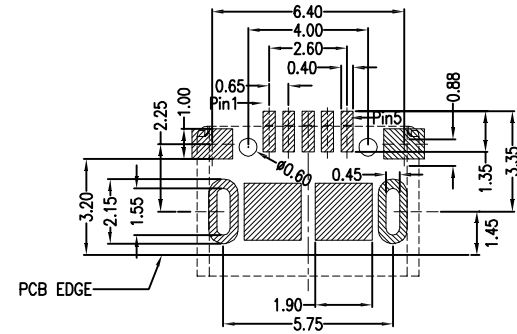
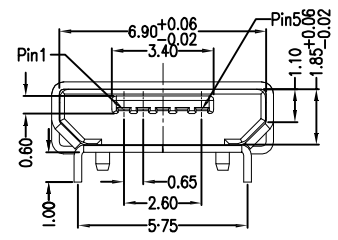
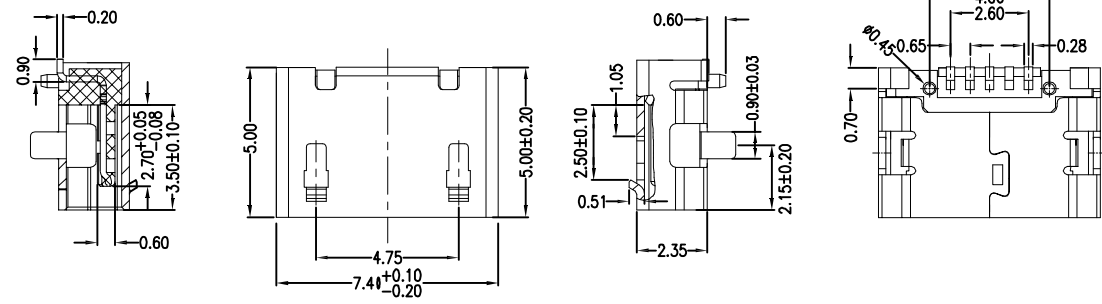

RECOMMENDED PCB LAYOUT
PCB图仅供参考

备注Note:

原材料Material:

1. 塑胶Housing: High temperature thermoplastic with g.f, UL94v-0
2. 端子Contact: copper alloy, t=0.15mm
3. 外壳Shell: copper alloy, t=0.25mm

规格说明Specification:

1. 额定电流Current rating: 1, 5PIN 1.8A Max/2, 3, 4PIN 1A Max.
2. 耐电压Dielectric withstanding voltage: 100 V(ac) for 1 min.
3. 接触阻抗Contact resistance: 30 mΩ Max.
4. 绝缘阻抗Insulation resistance: 100 MΩ Min.
5. 插入力Total mating force: 3.57 Kgf Max.
6. 拔出力Total unmating force: 1.0 Kgf Min.
7. 工作温度Temperature range: -30° C~80° C

端子电镀 01: Au1u"; 02: Au1.5u"; 03: Au3u"
05: Au5u"; 10: Au10u"; 15: Au15u"; 30: Au30u"

主体颜色 : 黑色

主体材质 : LCP

端子材质 : C5191R-EH

外壳电镀 1: N50u" 2: 雾T50u" 3: N+Au1u" (脚) 4: Au1u"

外壳材质: C2680R-H SUS304R-1/2H



深圳市华德共创科技有限公司
Shenzhen Huade co-create Technology Co., LTD
电话: 0755-27111216 传真: 0755-29940187

-TOLERANCES- UNLESS OTHERWISE SPECIFIED 公差参数表		TITLE: 产品名称: MICRO5.9 (5.0长) 平口铜壳滚镀 产品编号: 有柱针长1.0	
X.X ±0.30	X.X* ±3°	APPD: 核准:	PART NO: 产品编号: MICRO-ZL-115PWB
X.XX ±0.20	X.XX* ±2°	CHECK: 校对: 王建业	DATE SCALE UNIT CODE NUMBER
X.XXX ±0.10	X.XXX* ±1°	DRAW: 绘图: 黄艳兰	2016-03-12 1:1 mm A001

由 Autodesk 教育版产品制作