



钰地半导体
Tudi Semiconductor

Product Specification

TUDI-SP3232

True 3.0V to 5.5V RS-232 Transceivers

网址 www.sztdbdt.com 🔍

用芯智造 · 卓越品质

**semiconductor device
manufacturer**

- Design
- research and development
- production
- and sales



Features

- Powered by 3V to 5.5V VCC power supply
- Data rates up to 120kbps
- Low power current...300 μ A (typical)
- External capacitors ...4 \times 0.1 μ
- Accepts 5V logic inputs and 3.3V power
- Latch-up performance exceeds 100mA, compliant with JD 78 Class II specification requirements
- Provides ESD protection for RS-232 pins
 - \pm 15kV Human Body Model (BM)
 - \pm 15kV IEC 61000-4-2 Air Gap Discharge
 - \pm 8kV IEC61000-4-2 Contact Discharge

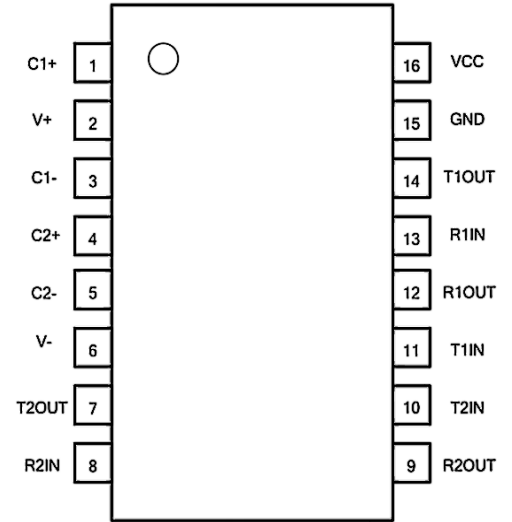

Figure 1. Pin Diagram

Explanation

The SP3232 series are RS-232 transceiver solutions intended for portable or hand-held applications such as notebook or palmtop computers. The SP3222E / SP3232E series has a highefficiency, charge-pump power supply that requires only 0.1 μ F capacitors in 3.3V operation. This charge pump allows the SP3232 series to deliver true RS-232 performance from a single power supply ranging from 3.0V to 5.5V. The SP3232 is 2-driver / 2-receiver devices. This series is ideal for portable or hand-held applications such as notebook or palmtop computers. The ESD tolerance of the SP3232 devices are over \pm 15kV for both Human Body Model and IEC61000-4-2 Air discharge test methods.

Applications

- Industrial PC
- Wired network
- Data center and enterprise-level computing
- Battery-powered system
- PDA
- Notebook
- PALM
- Handheld device



Pin description

PIN	SYMBOL	DESCRIPTION
1	C1+	Positive Terminal for the first Charge Pump Capacitor
2	V+	Doubled Voltage Terminal
3	C1-	Negative Terminal for the first Charge Pump Capacitor
4	C2+	Positive Terminal for the second Charge Pump Capacitor
5	C2-	Negative Terminal for the second Charge Pump Capacitor
6	V-	Inverted Voltage Terminal
7	T2OUT	Second Transmitter Output Voltage
8	R2IN	Second Receiver Input Voltage
9	R2OUT	Second Receiver Output Voltage
10	T2IN	Second Transmitter Input Voltage
11	T1IN	First Transmitter Input Voltage
12	R10UT	First Receiver Output Voltage
13	R1IN	First Receiver Input Voltage
14	T1OUT	First Transmitter Output Voltage
15	GND	Ground
16	VCC	Supply Voltage



Parameter limit

PARAMETER	SYMBOL	VALUE	UNIT
Supply voltage	VCC	-0.3~+6	V
Doubled Voltage Terminal	V+	VCC-0.3~+7	V
Inverted Voltage Terminal	V-	+0.3~-7	V
V++ V-		+13	V
Transmitter Input Voltage Range	T1IN,T2IN	-0.3~+6	V
Receiver Input Voltage Range	R1IN,R2IN	±25	V
Transmitter Output Voltage Range	T1OUT,T2OUT	±13.2	V
Receiver Output Voltage Range	R1OUT,R2OUT	-0.3~VCC+0.3	V
Operating Temperature		-40~85	°C
Storage Temperature		-60~150	°C
Soldering Temperature		300	°C
Continuous Power	SOP16	760	mW
	DIP16	840	mW

The maximum limit parameters means that exceeding these values may cause irreversible damage to the device. Under these conditions, it is not conducive to the normal operation of the device. The continuous operation of the device at the maximum allowable rating may affect the reliability of the device. The reference point for all voltages is ground.



PARAMETER	SYMBOL	CONDITION	MIN.	TYP.	MAX.	UNIT
ESD protection						
R1IN、R2IN T1OUT、T2OUT		HBM		±15		KV
		Air Discharge		±15		KV
		Contact Discharge		±8		KV
Switching Characteristics Parameter						
Rate	Speed	RL=3kΩ, CL=1000pF		120		kbps
Receiver Propagation delay	tRPHL	CL=150pF		300		ns
	tRPLH			300		ns
tRPHL-tRPLH				150		ns
tPHL-tPLH				150		ns
Transmitter Slew Rate	SR	RL=3kΩ~7kΩ, CL=150pF~1000pF	4		30	V/μs
Transmitter Output Electrical Characteristics						
Transmitter Output Swing	VTOUT	All output ports of	±4		±5	V
Transmitter Output Impedance	RTOUT	VCC=0V, Transmitter	300			Ω
Transmitter Short-Circuit Current	Itsc				60	mA
Receiver Output Electrical Characteristics						
Receiver Output Logic-Low Voltage	VROL	IOUT=1.6mA, VCC=5V or 3.3V			0.4	V
Receiver Output Logic-High Voltage	VROH	IOUT=-0.5mA, VCC=5V or 3.3V	VCC-0.6	VCC-0.1		V
Receiver Input Electrical Characteristics						
Receiver Input Range	VRIN		-25		+25	V
Receiver Input Low Threshold	VRIL	VCC=3.3V	0.6	1.1		V
		VCC=5V	0.8	1.5		V
Receiver Input High Threshold	VRIH	VCC=3.3V		1.5	2.4	V
		VCC=5V		1.9	2.4	V
Receiver Input Hysteresis				0.4		V
Receiver Input Impedance	RRIN		3	5	7	kΩ

(If there is no additional explanation,typical value is tested when VCC=+3.3V,Temp=25,C1-C4=1μF)

Circuit test

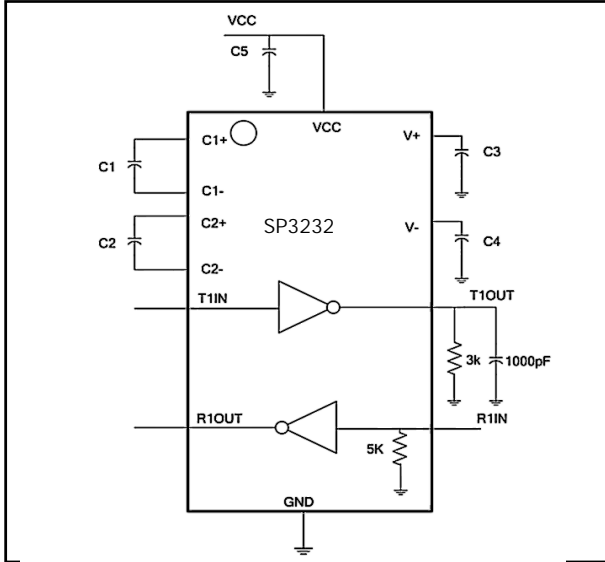

Figure 2 minimum swing rate test circuit

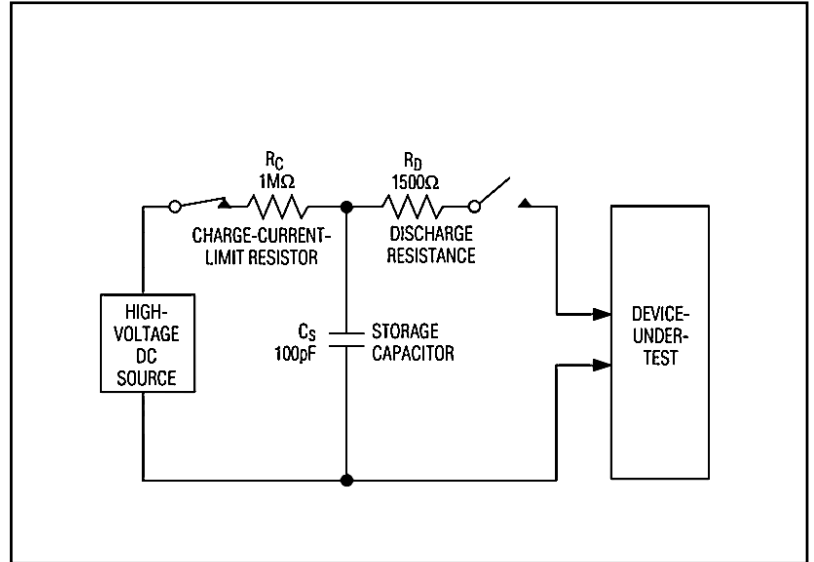

Figure 4 ESD test model of human body mode

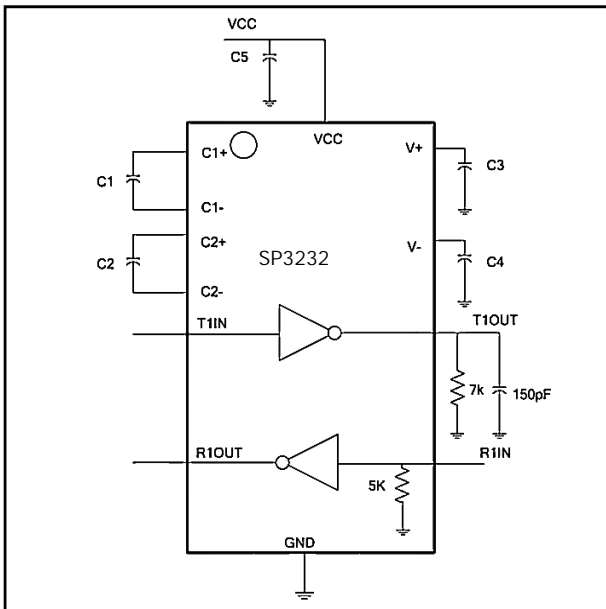

Figure 3 maximum swing rate test circuit

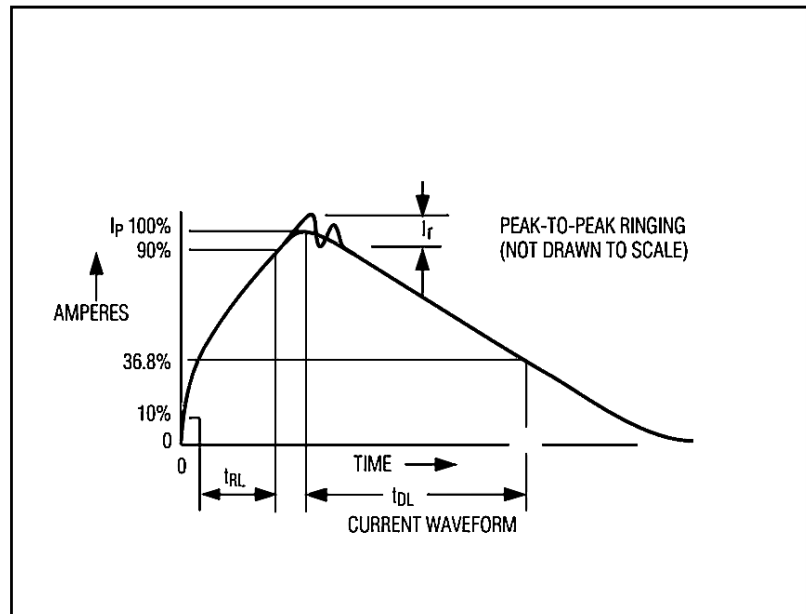

Figure 5 human body mode current waveform

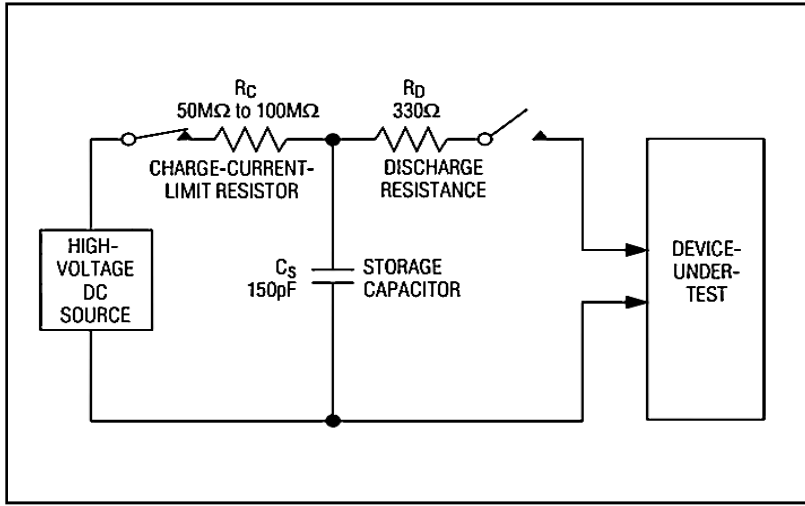

Figure 6 ESD test model of IEC 1000-4-2

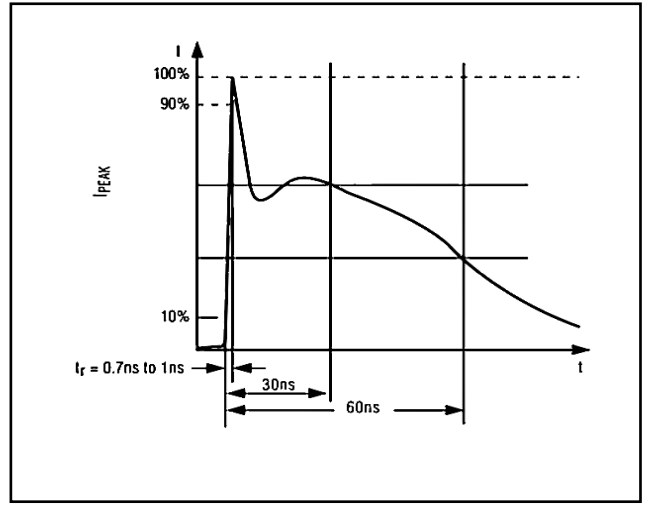

Figure 7 current waveform of IEC 1000-4-2 ESD

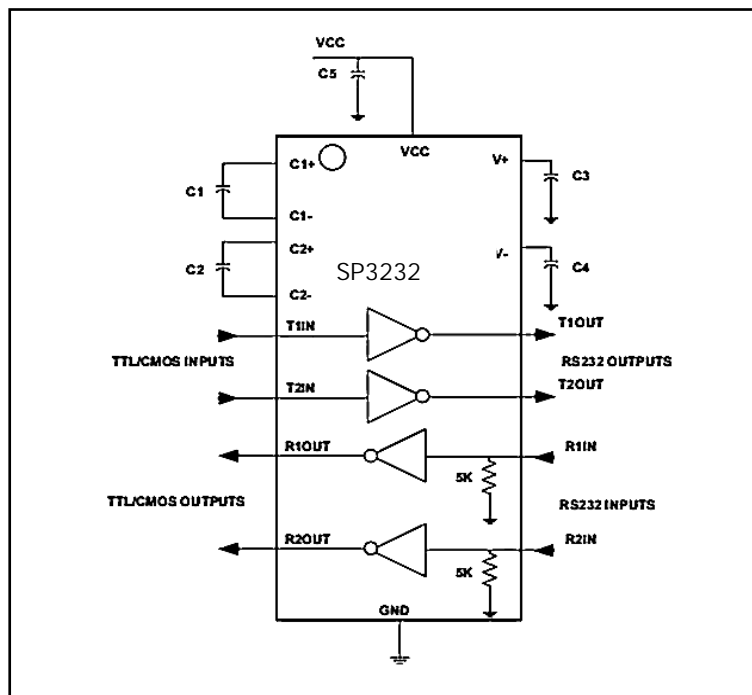

Figure 8 Typical dual-Path application scenarios



Additional description

ESD Protection

All pins of SP3232 adopt ESD protection structure, and all driver outputs and receiver inputs have additional electrostatic protection capability. It can withstand $\pm 15\text{kV}$ ESD (HBM) discharge, contact discharge above $\pm 8\text{kV}$ and air gap discharge above $\pm 15\text{kV}$. The ESD protection structure can withstand the impact of high voltage ESD under all conditions, including standard working mode and power -off mode.

Typical Application

Typical dual-Path application scenarios are shown in Figure 8, where the C1-C5 typical capacitance value is $0.1\mu\text{F}$

Dual Charge-Pump Operation

SP3232 has a two-way charge pump inside to support the chip's voltage conversion work. Dual-electric pump provides $+5.5\text{V}$ and -5.5V output voltage in the range of $3.0 \sim 5.5\text{V}$. Each charge pump requires a capacitor (C1, C2) and an energy storage capacitor (C3, C4) to generate $V+$ and $V-$ power supplies, as shown in Fig 8.

RS232 Transmitter

Convert the TTL/CMOS logic voltage to a voltage compatible with the EIA/TIA-232 standard. SP3232 Transmitter can guarantee 120kbps data rate under the worst operating conditions (Parallel load of $3\text{k}\Omega$ resistor and 1000pF capacitor). Transmitter can drive multiple receivers in parallel. There is no pull-up resistance inside the input terminals T1IN and T2IN of SP3232 transmitter. If the transmitter is not used, the unused input terminals T1IN and T2IN can be connected to GND or VCC.

RS232 Receiver

The SP3232 has two separate receivers that convert the RS-232 signal to the CMOS logic output level.



Package TSSOP16

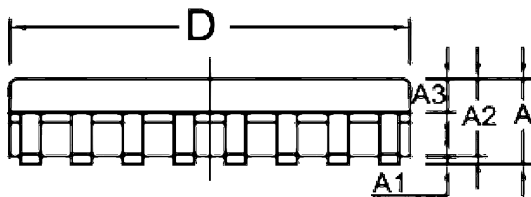
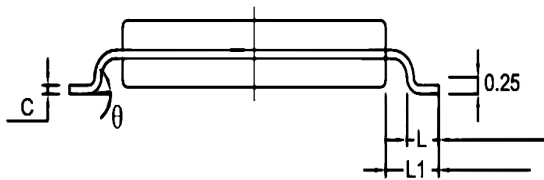
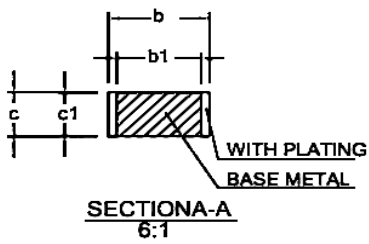
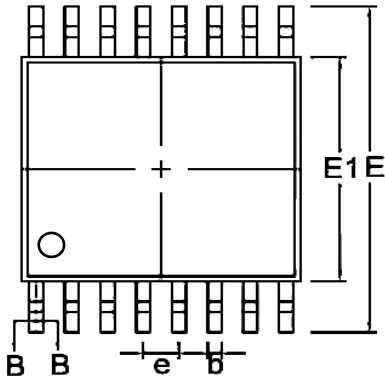

SIZE SYMBOL	MIN./mm	TYP./mm	MAX./mm
A	--	--	1.20
A1	0.05		0.15
A2	0.90	1.00	1.05
b	0.20	--	0.30
b1	0.19	0.22	0.25
C	0.110	0.127	0.145
cl	0.12	0.13	0.14
D	4.86	4.96	5.06
E	6.20	6.40	6.60
E1	4.30	4.40	4.50
e	0.65BSC		
L	0.45	0.60	0.75
L1	1.00BSC		
	0°	--	8°



Package SSOP16

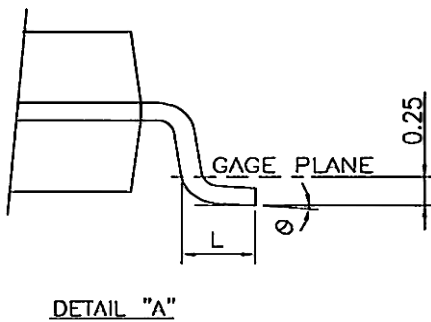
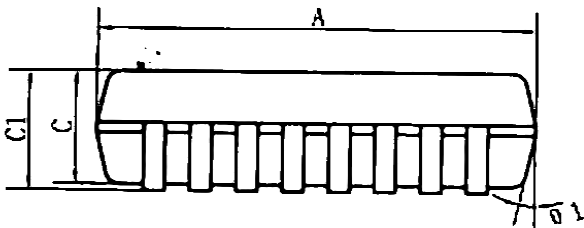
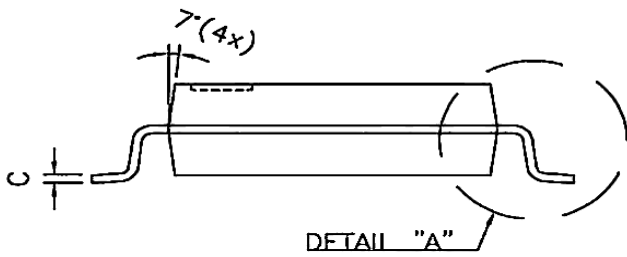
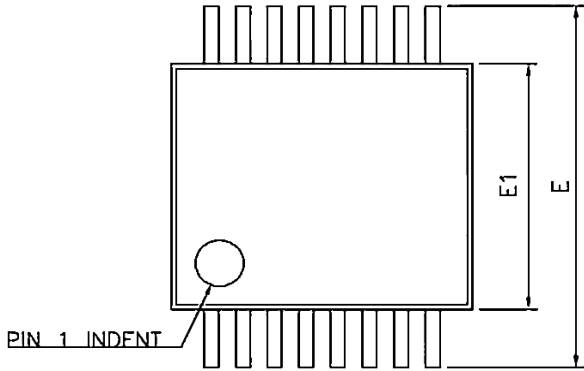

SIZE SYMBOL	MIN/mm	MAX/mm
A	6.15	6.25
A1	0.30TYP	
A2	0.65TYP	
A3	0.675TYP	
B	5.25	5.35
B1	7.65	7.95
B2	0.60	0.80
C	1.70	1.80
C1	1.75	1.95
C2	0.799	
C3	0.152	
C4	0.172	
H	0.05	0.15
θ	12°TYP4	
O1	12°TYP4	
O2	10°TYP	
O3	0°~8°	
R	0.20°TYP	
R	0.15°TYP	



Package SOP16

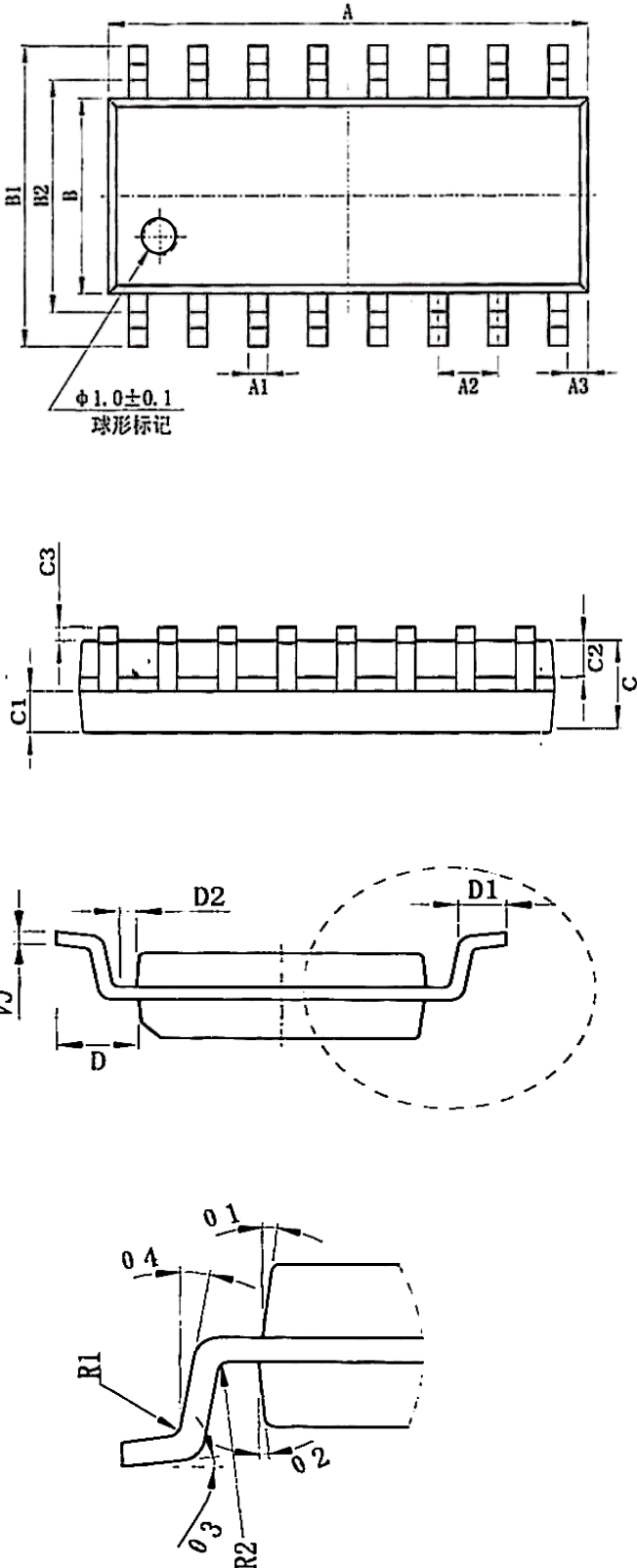

SIZE	MIN./mm	MAX./mm
SYMBOL		
A	9.80	10.00
A1	0.356	0.456
A2	1.27TYP	
A3	0.302TYP	
B	3.85	3.95
B1	5.84	6.24
B2	5.00 TYP	
C	1.40	1.60
C1	0.61	0.71
C2	0.54	0.64
C3	0.05	0.25
C4	0.203	0.233
D	1.05 TYP	
D1	0.40	0.70
D2	0.15	0.25
R1	0.20TYP	
R2	0.20TYP	
O1	8°~12°TYP4	
O2	8°~12°TYP4	
O3	0°~8°	
O4	4°~12°	



Package SMD16

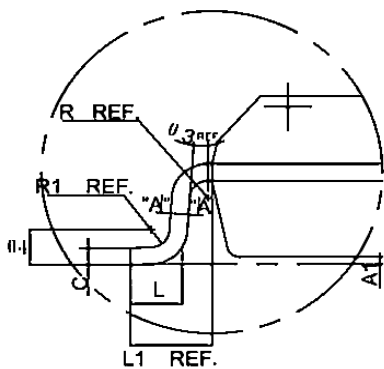
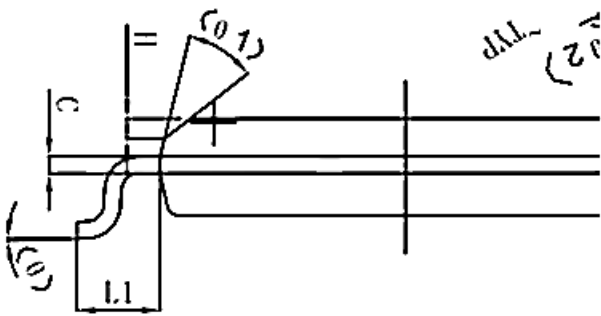
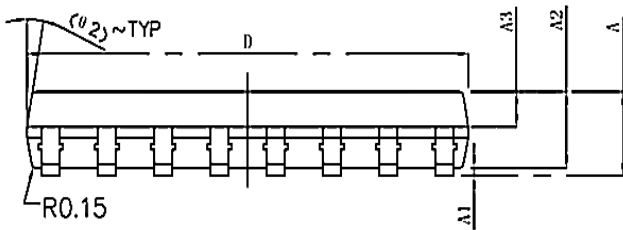
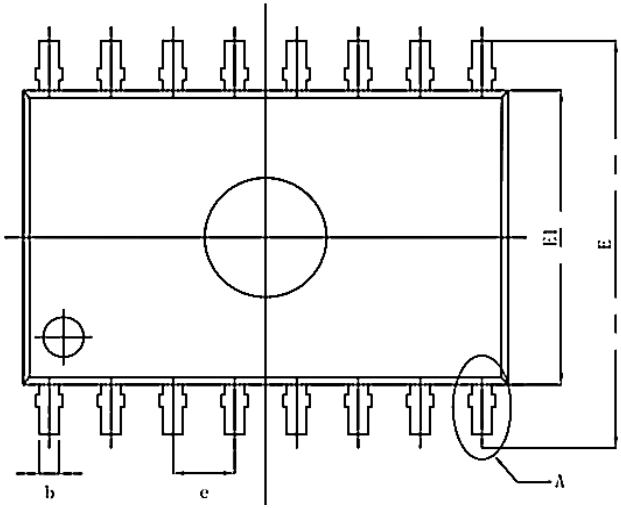

SIZE SYMBOL	MIN./mm	MAX./mm
A	-	2.65
A1	0.10	0.30
A2	2.25	2.35
A3	0.97	1.07
D	10.10	10.50
E	10.26	10.60
E1	7.30	7.70
e	1.27BSC	
L	0.55	0.85
L1	1.4BSC	
H	0.345	0.365
R	0.20TYP	
R1	0.30TYP	
θ	0°	8°
$\theta 1$	45° TYP	
02	12° TYP	
03	0°	8°
04	0°	10°



Package DIP16

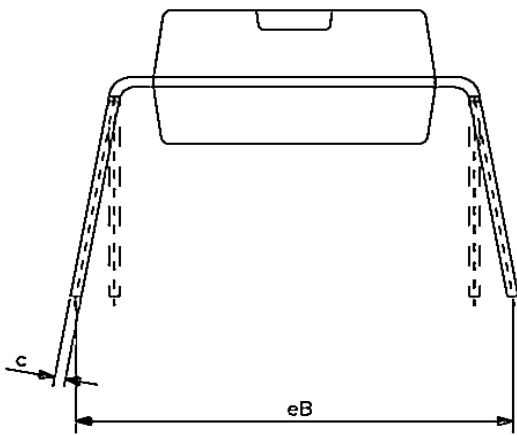
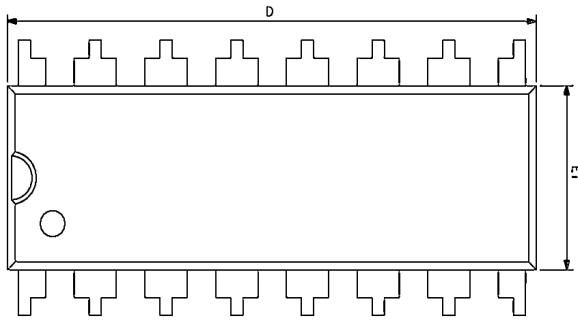
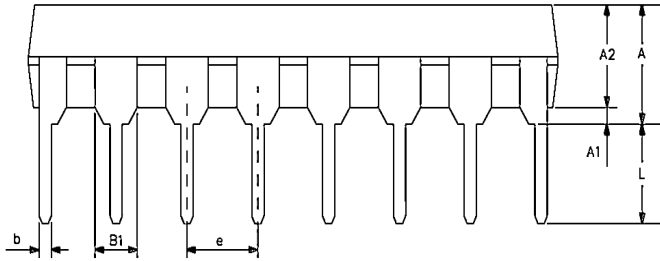

SIZE SYMBOL	MIN./mm	MAX./mm
A2	3.20	3.60
A1	0.51	—
A	3.60	5.33
L	3.00	3.60
b	0.36	0.56
B1	1.52	
D	18.80	19.94
E1	6.20	6.60
e	2.54	
C	0.20	0.36
eB	7.62	9.30
R	0.20TYP	
R1	0.30TYP	
θ	0°	8°
θ_1	45°TYP	
θ_2	12°TYP	
θ_3	0°	8°
θ_4	0°	10°



Order information

Order Number	Package	Package Quantity	Marking On The park	Temperature
SP3232ECA-L/TR-TUDI	SSOP16	Tape,Reel,2000	SP3232ECA	0°C to +70°C
SP3232ECN-L/TR-TUDI	SOP16	Tape,Reel,2500	SP3232ECN	
SP3232ECT-L/TR-TUDI	SMD16	Tape,Reel,1000	SP3232ECT	
SP3232ECY-L/TR-TUDI	TSSOP16	Tape,Reel,2500	3232EC	
SP3232ECP-TUDI	DIP16	Tube,25,A box of 1000	SP3232ECP	
SP3232EEA-L/TR-TUDI	SSOP16	Tape,Reel,2000	SP3232EEA	-40°C to +85°C
SP3232EEN-L/TR-TUDI	SOP16	Tape,Reel,2500	SP3232EEN	
SP3232EET-L/TR-TUDI	SMD16	Tape,Reel,1000	SP3232EET	
SP3232EEY-L/TR-TUDI	TSSOP16	Tape,Reel,2500	3232EE	
SP3232EEP-TUDI	DIP16	Tube,25,A box of 1000	SP3232EEP	



Important statement:

- TUDI Semiconductor reserves the right to modify the product manual without prior notice! Before placing an order, customers need to confirm whether the obtained information is the latest version and verify the completeness of the relevant information.
- Any semi-guide product is subject to failure or malfunction under specified conditions. It is the buyer's responsibility to comply with safety standards when using TUDI Semiconductor products for system design and whole machine manufacturing. And take the appropriate safety measures to avoid the potential in the risk of loss of personal injury or loss of property situation!
- TUDI Semiconductor products have not been licensed for life support, military, and aerospace applications, and therefore TUDI Semiconductor is not responsible for any consequences arising from the use of this product in these areas.
- If any or all TUDI Semiconductor products (including technical data, services) described or contained in this document are subject to any applicable local export control laws and regulations, they may not be exported without an export license from the relevant authorities in accordance with such laws.
- The specifications of any and all TUDI Semiconductor products described or contained in this document specify the performance, characteristics, and functionality of said products in their standalone state, but do not guarantee the performance, characteristics, and functionality of said products installed in Customer's products or equipment. In order to verify symptoms and conditions that cannot be evaluated in a standalone device, the Customer should ultimately evaluate and test the device installed in the Customer's product device.
- TUDI Semiconductor documentation is only allowed to be copied without any alteration of the content and with the relevant authorization. TUDI Semiconductor assumes no responsibility or liability for altered documents.
- TUDI Semiconductor is committed to becoming the preferred semiconductor brand for customers, and TUDI Semiconductor will strive to provide customers with better performance and better quality products.