

由 Autodesk 教育版产品制作

修 订	标 记	修 改 描 要	签 名	日 期
REV	NO	DESCRIPTION	SIGNATURE	DATE
		NEW DRG		2016-03-12

- SPECIFICATIONS:**
- ELECTRICAL CHARACTERISTICS:**
    - CONTACT RESISTANCE: 30mΩ MAX.
    - DIELECTRIC WITHSTANDING VOLTAGE: 100V AC FOR ONE MINUTE.
    - INSULATION RESISTANCE: 100MΩ MIN. MEASURED BY 500 VDC
  - MECHANICAL CHARACTERISTICS:**
    - INSERTION FORCE :0.5-2.0KgF(REF.)
    - WITHDRAWAL FORCE :0.8-2.0KgF(REF.)
  - LIFE TEST: 10,000 CYCLES.
  - TO CONFORM TO THE KRCONN HAZARDOUS SUBSTANCE FREE SPEC.

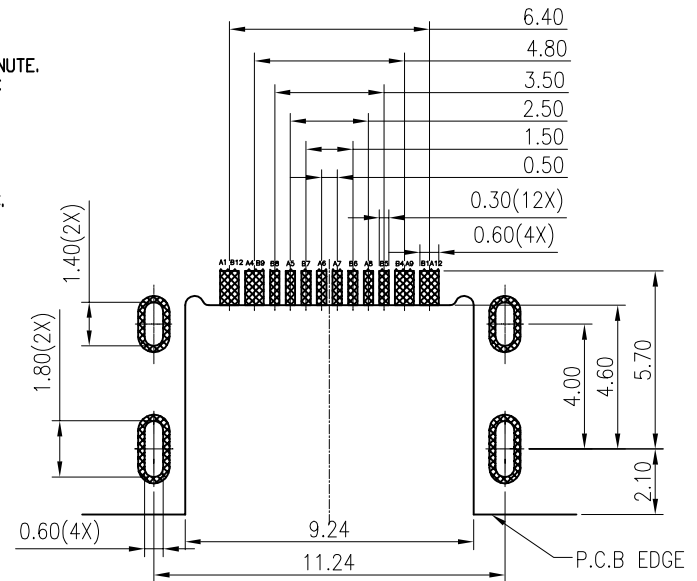
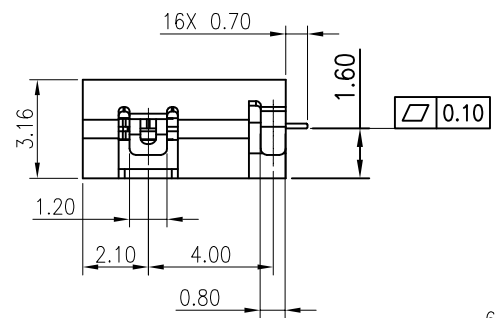
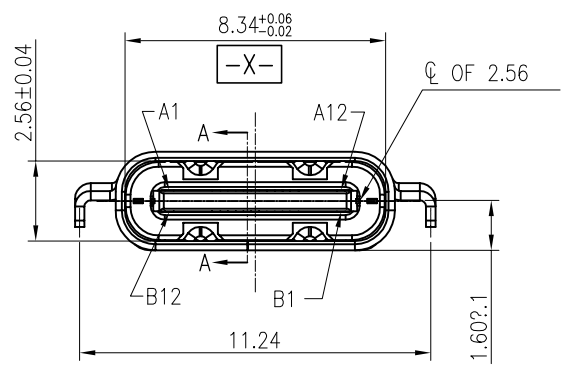
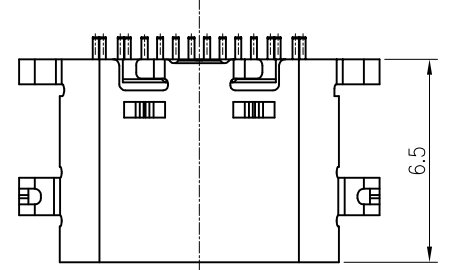

RECOMMENDED PCB LAYOUT(TOP VIEW)  
THICKNESS 0.80MM;DEFAULT TOLERANCE:±0.05

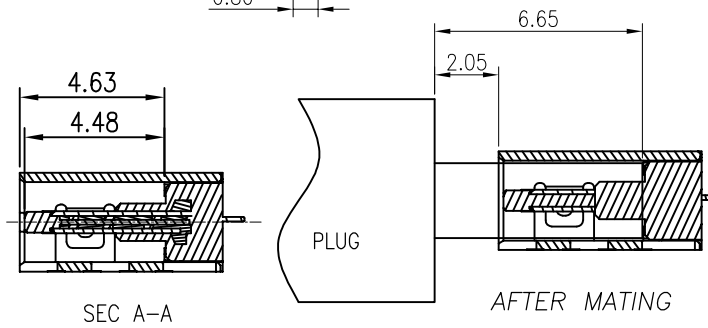
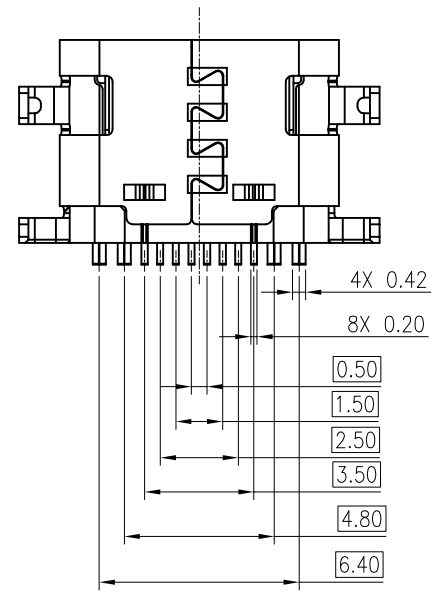
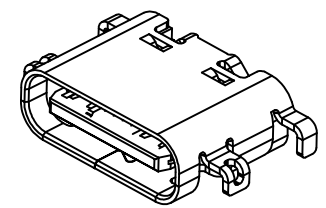

NO.	DESCRIPTION	MATERIAL	REMARKS	QTY
6	SHELL	STAINLESS STEEL	Ni Plated	1PCS
5	SHIELDING PLATE	STAINLESS STEEL	---	1PCS
4	MD	HIGH TEMPERATURE PLASTIC		1PCS
3	CONTACT	COPPER ALLOY	Au/Ni Plated	1SET
2	CONTACT	COPPER ALLOY	Au/Ni Plated	1SET
1	HOUSING	HIGH TEMPERATURE PLASTIC		1PCS

PIN	SIGNAL NAME	PIN	SIGNAL NAME
A1	GND	B12	GND
A4	VBUS	B9	VBUS
A5	CC1	B8	SBU2
A6	DP1	B7	DN2
A7	DN1	B6	DP2
A8	SBU1	B5	CC2
A9	VBUS	B4	VBUS
A12	GND	B1	GND

深圳市华德共创科技有限公司  
Shenzhen Huade co-create Technology Co.,LTD  
电话: 0755-27111216 传真: 0755-29940187

TITLE: TYPE C 16PIN卧式带钢片沉板1.6 黑色  
产品名称: 黑色

PART NO: TYPE C-ZL-110PWB  
产品编号:

-TOLERANCES- UNLESS OTHERWISE SPECIFIED 公差参数表		APPD: 核准:		DATE			
X.X	±0.30	X.X*	±3°	SCALE			
X.XX	±0.20	X.XX*	±2°	UNIT			
X.XXX	±0.10	X.XXX*	±1°	CODE NUMBER			

王建业

黄艳兰

2016-03-12

1:1

mm

A001

由 Autodesk 教育版产品制作