

LOW DROPOUT POSITIVE VOLTAGE REGULATOR

FEATURES

- Adjustable or Fixed Output 3.3V,5.0V
- Output Current of 3A
- Low Dropout, 1.5V max at 3A Output Current
- 0.04% Line Regulation
- 0.2 % Load Regulation
- 100% Thermal Limit Burn-In
- Fast Transient Response



ORDERING INFORMATION

DEVICE	Package Type	MARKING	Packing	Packing Qty
LM1085T-3.3	TO-220-3	LM1085-3.3	TUBE	1000pcs/Box
LM1085T-5.0	TO-220-3	LM1085-5.0	TUBE	1000pcs/Box
LM1085T-ADJ	TO-220-3	LM1085-ADJ	TUBE	1000pcs/Box
LM1085S-3.3/TR	TO-263-3	LM1085-3.3	REEL	500pcs/Reel
LM1085S-5.0/TR	TO-263-3	LM1085-5.0	REEL	500pcs/Reel
LM1085S-ADJ/TR	TO-263-3	LM1085-ADJ	REEL	500pcs/Reel
LM1085MDT-3.3/TR	TO-252-2	LM1085-3.3	REEL	2500pcs/Reel
LM1085MDT-5.0/TR	TO-252-2	LM1085-5.0	REEL	2500pcs/Reel
LM1085MDT-ADJ/TR	TO-252-2	LM1085-ADJ	REEL	2500pcs/Reel
LM1085S2-3.3/TR	TO-263-2	LM1085-3.3	REEL	500pcs/Reel
LM1085S2-5.0/TR	TO-263-2	LM1085-5.0	REEL	500pcs/Reel
LM1085S2-ADJ/TR	TO-263-2	LM1085-ADJ	REEL	500pcs/Reel

DESCRIPTION

The LM1085 series of positive adjustable and fixed regulators are designed to provide 3A with high efficiency. All internal circuitry is designed to operate down to 1.3V input to output differential. On-chip trimming adjusts the reference voltage to 1%.

APPLICATIONS

- High Efficiency Linear Regulators
- Post Regulators for Switching Supplies
- Adjustable Power Supply

PIN DESCRIPTION

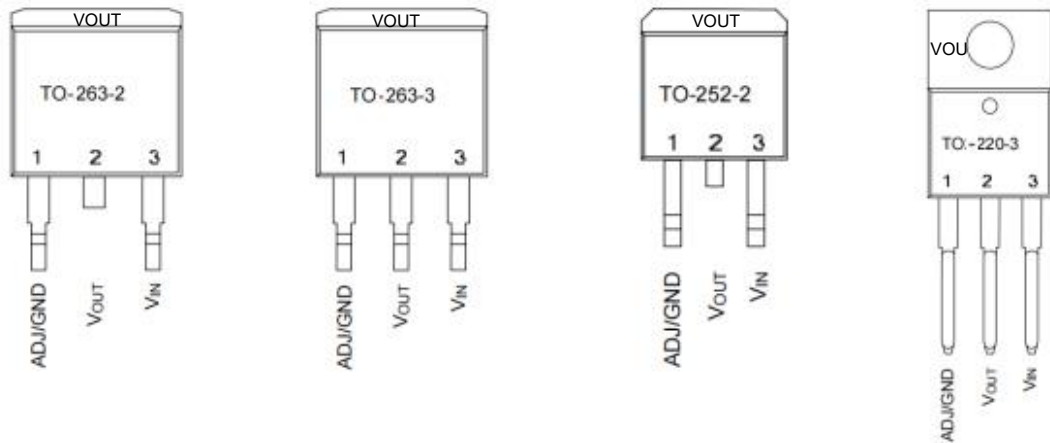

TYPICAL APPLICATION DATA

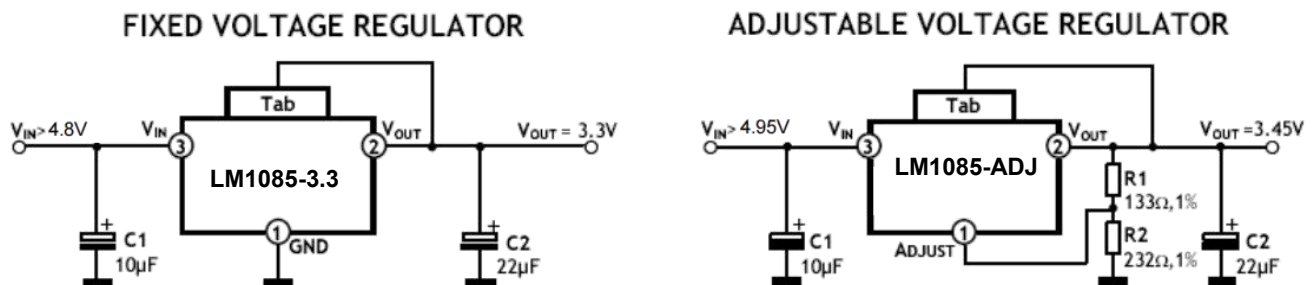

NOTES:

- C1 needed if device far from filter capacitors
- C2 minimum value required for stability

$$V_{OUT} = V_{REF} \times \left(1 + \frac{R2}{R1}\right) + I_{ADJ} \times R2$$

ABSOLUTE MAXIMUM RATINGS

SYMBOL	PARAMETER	VALUE	UNIT
VCC	Power Dissipation	Internally Limited	W
V _{IN}	Input Voltage	15	V
T _J	Operation Junction Temperature Range		°C
		Control Section	
		Power Transistor	-40 to 150
TSTG	Storage Temperature Range	-65 to +150	°C
TLEAD	Lead Temperature (Soldering 10 sec)	TO-220/TO-263	245
		TO-252	260

Note: Absolute Maximum Ratings indicate limits beyond which damage to the device may occur. Operating Ratings indicate conditions for which the device is intended to be functional, but specific performance is not ensured.

ELECTRICAL CHARACTERISTICS
 $I_{LOAD} = 0mA$ and $T_J = -40\sim 125^{\circ}C$ (unless otherwise noted)

PARAMETER	DEVICE	TEST CONDITIONS	MIN.	TYP.	MAX.	UNIT
Reference Voltage ^(Note 1)	LM1085	$V_{IN} - V_{OUT} = 1.5V$ to 10V, $I_{LOAD} = 10mA$ to 3A	1.225	1.250	1.275	V
Output Voltage ^(Note 1)	All fixedversions	$V_{IN} - V_{OUT} = 1.5V$ to 10V $I_{LOAD} = 0mA$ to 3A, Variator from nominal V_{OUT}	-2	-	+2	%
Line Regulation ^(Note 1)	All	$I_{LOAD} = 10mA$, $V_{IN} - V_{OUT} = 1.5V$ to 10V	-	0.04	0.20	%
Load Regulation ^(Note 1)	All	$V_{IN} - V_{OUT} = 1.5V$ $I_{LOAD} = 10mA$ to 3A	-	0.2	0.40	
Minimum Load Current	LM1085	$V_{IN} = 5V$, $V_{ADJ} = 0V$	-	3	7	mA
Ground Pin Current	All fixedversions	$V_{IN} - V_{OUT} = 1.5V$ $I_{LOAD} = 10mA$ to 3A	-	7	10	mA
Adjust Pin Current	LM1085	$V_{IN} - V_{OUT} = 1.5V$ to 10V $I_{LOAD} = 10mA$	-	40	90	μA
Current Limit	All	$V_{IN} - V_{OUT} = 1.5V$	3	4.5	-	A
Ripple Rejection ^(Note 2)	All	$V_{IN} - V_{OUT} = 3V$ $I_{LOAD} = 3A$	60	65	-	dB
Dropout Voltage ^(Note 1, 3)	All	$I_{LOAD} = 3A$	-	1.3	1.5	V
Temperature Coefficient	All	$V_{IN} - V_{OUT} = 1.5V$, $I_{LOAD} = 10mA$	-	0.005	-	%/ $^{\circ}C$

NOTES:

1. Low duty pulse testing with Kelvin connections required.
2. 120Hz input ripple (C_{ADJ} for ADJ = 25 μF , $C_{OUT} = 25\mu F$)
3. ΔV_{OUT} , $\Delta V_{REF} = 2\%$

APPLICATION INFORMATION

The LM1085 series of adjustable and fixed regulators are easy to use and have all the protection features expected in high performance voltage regulators: short circuit protection and thermal shut-down.

Pin compatible with older three terminal adjustable regulators, these devices offer the advantage of a lower dropout voltage, more precise reference tolerance and improved reference stability with temperature.

STABILITY

The circuit design used in the LM1085 series requires the use of an output capacitor as part of the device frequency compensation.

The addition of 150 μ F aluminum electrolytic or a 22 μ F solid tantalum on the output will ensure stability for all operating conditions.

When the adjustment terminal is bypassed with a capacitor to improve the ripple rejection, the requirement for an output capacitor increases. The value of 22 μ F tantalum or 150 μ F aluminum covers all cases of bypassing the adjustment terminal. Without bypassing the adjustment terminal smaller capacitors can be used with equally good results. To ensure good transient response with heavy load current changes capacitor values on the order of 100 μ F are used in the output of many regulators. To further improve stability and transient response of these devices larger values of output capacitor can be used.

PROTECTION DIODES

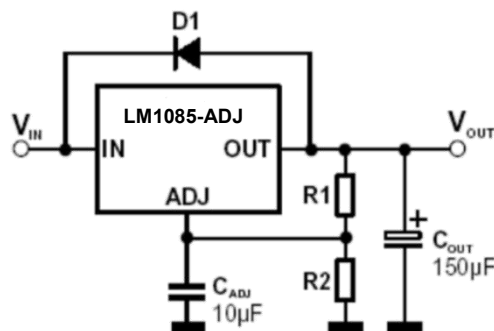

Unlike older regulators, the LM1085 family does not need any protection diodes between the adjustment pin and the output and from the output to the input to prevent over-stressing the die.

Internal resistors are limiting the internal current paths on the LM1085 adjustment pin, therefore even with capacitors on the adjustment pin no protection diode is needed to ensure device safety under short-circuit conditions.

Diodes between the input and output are not usually needed.

Microsecond surge currents of 50A to 100A can be handled by the internal diode between the input and output pins of the device. In normal operations it is difficult to get those values of surge currents even with the use of large output capacitances. If high value output capacitors are used, such as 1000 μ F to 5000 μ F and the input pin is instantaneously shorted to ground, damage can occur. A diode from output to input is recommended, when a crowbar circuit at the input of the LM1085 is used. Normal power supply cycling or even plugging and unplugging in the system will not generate current large enough to do any damage.

The adjustment pin can be driven on a transient basis ± 25 V, with respect to the output without any device degradation. As with any IC regulator, none the protection circuitry will be functional and the internal transistors will break down if the maximum input to output voltage differential is exceeded.

RIPPLE REJECTION

The ripple rejection values are measured with the adjustment pin bypassed. The impedance of the adjust pin capacitor at the ripple frequency should be less than the value of R1 (normally 100 Ω to 120 Ω) for a proper bypassing and ripple rejection approaching the values shown. The size of the required adjust pin capacitor is a function of the input ripple frequency. If R1=100 Ω at 120Hz the adjust pin capacitor should be 25 μ F. At 10 kHz only 0.22 μ F is needed.

The ripple rejection will be a function of output voltage, in circuits without an adjust pin bypass capacitor. The output ripple will increase directly as a ratio of the output voltage to the reference voltage (V_{OUT} / V_{REF}).

OUTPUT VOLTAGE

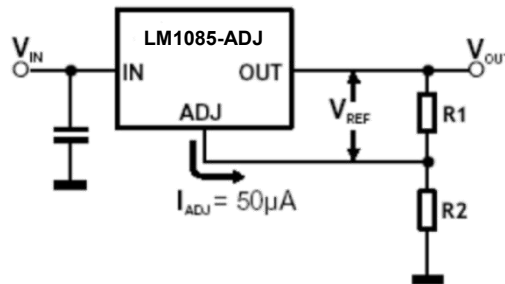

The LM1085 series develops a 1.25V reference voltage between the output and the adjust terminal. Placing a resistor between these two terminals causes a constant current to flow through R_1 and down through R_2 to set the overall output voltage.

This current is normally the specified minimum load current of 10mA. Because I_{ADJ} is very small and constant it represents a small error and it can usually be ignored.

LOAD REGULATION

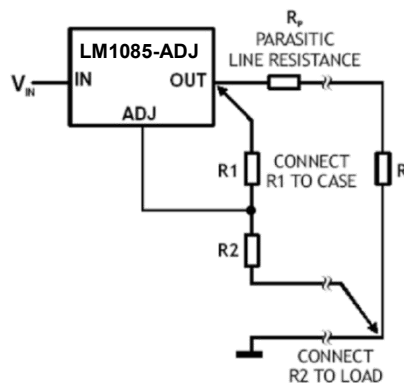

True remote load sensing it is not possible to provide, because the LM1085 is a three terminal device. The resistance of the wire connecting the regulator to the load will limit the load regulation.

The data sheet specification for load regulation is measured at the bottom of the package. Negative side sensing is a true Kelvin connection, with the bottom of the output divider returned to the negative side of the load.

The best load regulation is obtained when the top of the resistor divider R_1 is connected directly to the case not to the load. If R_1 were connected to the load, the effective resistance between the regulator and the load would be:

$$\frac{R_p \times (R_2 + R_1)}{R_1}, R_p = \text{Parasitic Line Resistance}$$

Connected as shown Fig.3, R_p is not multiplied by the divider ratio. Using 16-gauge wire the parasitic line resistance is about 0.004Ω per foot, translating to 4mV/ft at 1A load current. It is important to keep the positive lead between regulator and load as short as possible and use large wire or PC board traces.

THERMAL CONSIDERATIONS

The LM1085 series have internal power and thermal limiting circuitry designed to protect the device under overload conditions. However maximum junction temperature ratings should not be exceeded under continuous normal load conditions.

Careful consideration must be given to all sources of thermal resistance from junction to ambient, including junction-to-case, case-to-heat sink interface and heat sink resistance itself. To ensure safe operating temperatures and reflect more accurately the device temperature, new thermal resistance specifications have been developed. Unlike older regulators with a single junction-to-case thermal resistance specification, the data section for these new regulators provides a separate thermal resistance and maximum junction temperature for both the Control Section and the Power Transistor. Calculations for both temperatures under certain conditions of ambient temperature and heat sink resistance and to ensure that both thermal limits are met.

Junction-to-case thermal resistance is specified from the IC junction to the bottom of the case directly below the die. This is the lowest resistance path for the heat flow. In order to ensure the best possible thermal flow from this area of the package to the heat sink proper mounting is required. Thermal compound at the case-to-heat sink interface is recommended. A thermally conductive spacer can be used, if the case of the device must be electrically isolated, but its added contribution to thermal resistance has to be considered.

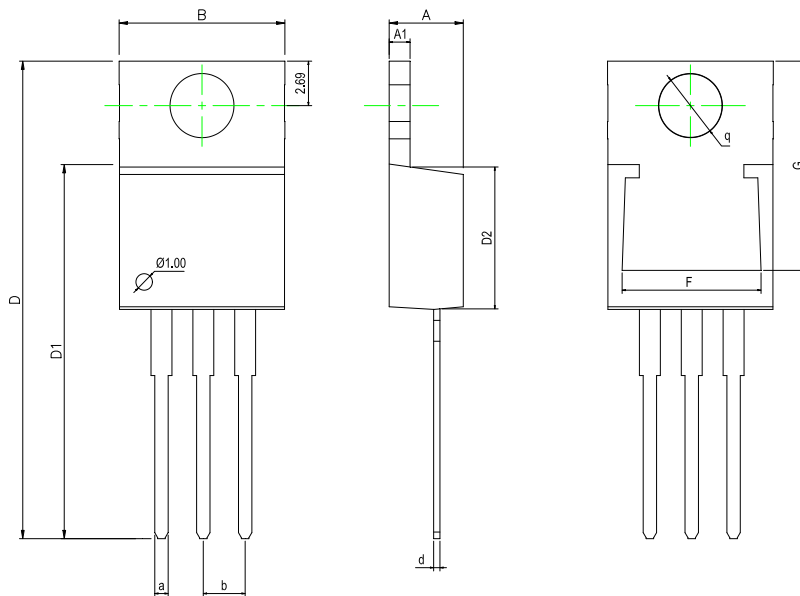
PHYSICAL DIMENSIONS
TO-220-3

Dimensions In Millimeters(TO-220-3)

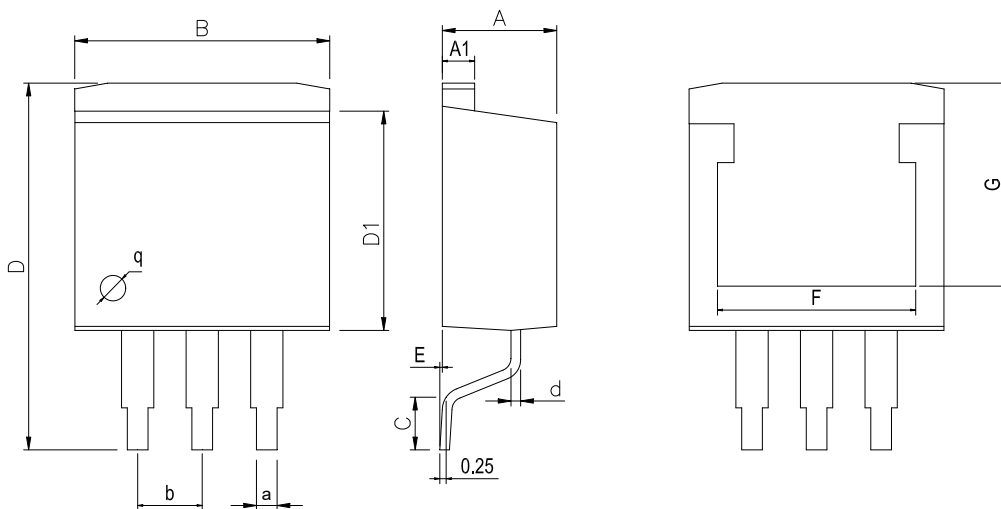
Symbol:	A	A1	B	D	D1	D2	F	G	a	d	b	q
Min:	4.45	1.22	10	28.2	22.22	8.50	8.30	12.55	0.71	0.33	2.54	3.80
Max:	4.62	1.32	10.4	28.9	22.62	9.10	8.55	12.75	0.97	0.42	BSC	TYP

TO-263-3

Dimensions In Millimeters(TO-263-3)

Symbol:	A	A1	B	C	D	D1	E	F	G	a	b
Min:	4.45	1.22	10	1.89	14.1	8.38	0	7.20	7.20	0.71	2.54BSC
Max:	4.62	1.32	10.4	2.19	15.3	8.89	0.305	8.10	8.10	0.97	

PHYSICAL DIMENSIONS

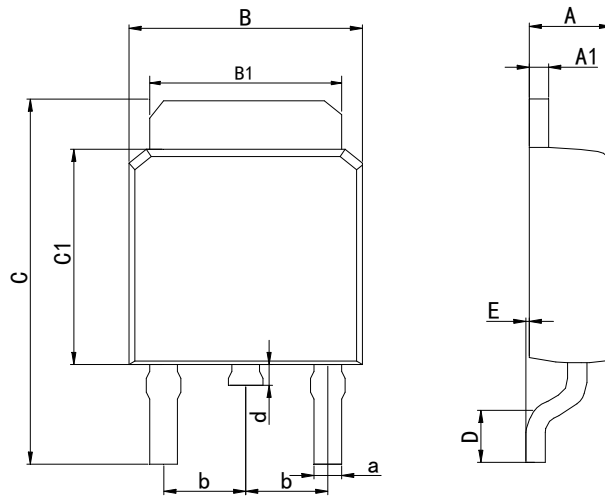
TO-252-2



Dimensions In Millimeters(TO-252-2)

Symbol:	A	A1	B	B1	C	C1	D	E	a	d	b
Min:	2.10	0.45	6.40	5.10	9.20	5.30	0.90	0	0.50	0.60	2.28
Max:	2.50	0.70	6.80	5.50	10.6	6.30	1.75	0.23	0.80	1.20	BSC

TO-263-2

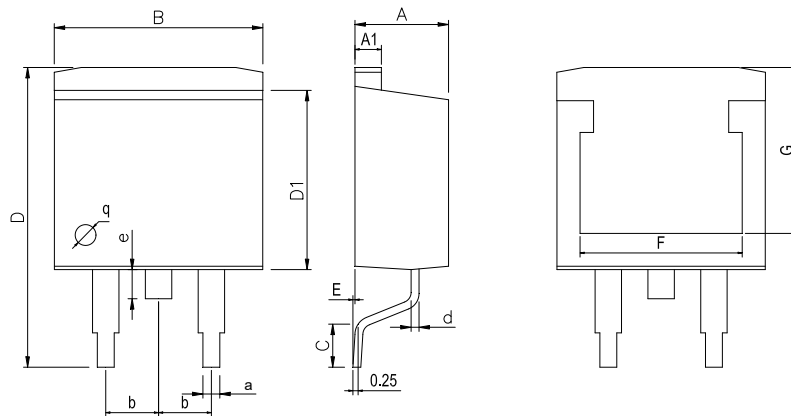

Dimensions In Millimeters(TO-263-2)

Symbol:	A	A1	B	C	D	D1	E	F	G	a	e	b
Min:	4.45	1.22	10	2.25	14.5	8.45	0	7.20	7.20	0.71	1.10	2.54BSC
Max:	4.62	1.32	10.4	2.85	15.4	9.10	0.305	8.10	8.10	0.97	1.70	

REVISION HISTORY

REVISION NUMBER	DATE	REVISION	PAGE
V1.0	2019-6	New	1-10
V1.1	2023-9	Update encapsulation type、 Update Pin Description	1、 2
V1.2	2024-11	Update TO263-2 packaging dimension diagram、 Update Lead Temperature	2、 8
V1.3	2025-12	Update important statements、 Update sop-8 Dimension drawing	7、 10
V1.4	2026-5	Update Electrical Characteristics	3

IMPORTANT STATEMENT:

Huaguan Semiconductor reserves the right to change products and services offered without prior notice. Customers should obtain the latest relevant information before placing orders and verify that such information is current and complete. Huaguan Semiconductor assumes no responsibility or liability for altered documents.

Customers are responsible for complying with safety standards and implementing safety measures when using Huaguan Semiconductor products in system design and end-product manufacturing. You assume full responsibility for: selecting the appropriate Huaguan Semiconductor products for your application; designing, validating, and testing your application; and ensuring that your application complies with applicable standards and all other safety, security, or other requirements. This is to prevent potential risks that may lead to personal injury or property damage.

Huaguan Semiconductor products are not approved for use in life support, military, aerospace, or other high-risk applications. Huaguan products are neither intended nor warranted for use in such systems or equipment. Any failure or malfunction may lead to personal injury or severe property damage. Such applications are deemed "Unsafe Use." Unsafe Use includes, but is not limited to: surgical and medical equipment, nuclear energy control equipment, aircraft or spacecraft instruments, control or operation of vehicle power, braking, or safety systems, traffic signal instruments, all types of safety devices, and any other applications intended to support or sustain life. Huaguan Semiconductor shall not be liable for consequences resulting from Unsafe Use in these fields. Users must independently evaluate and assume all risks. Any issues, liabilities, or losses arising from the use of products beyond their approved applications shall be solely borne by the user. Users may not claim any compensation from Huaguan Semiconductor based on these terms. If any third party claims against Huaguan Semiconductor due to such Unsafe Use, the user shall compensate Huaguan Semiconductor for all resulting damages and liabilities.

Huaguan Semiconductor provides technical and reliability data (including datasheets), design resources (including reference designs), application or other design advice, web tools, safety information, and other resources for its semiconductor products. However, no guarantee is made that these resources are free from defects, and no express or implied warranties are provided. The use of testing and other quality control techniques is limited to Huaguan Semiconductor's quality assurance scope. Not all parameters of each device are tested.

Huaguan Semiconductor's documentation authorizes you to use these resources only for developing applications related to the products described herein. You are not granted rights to any other intellectual property of Huaguan Semiconductor or any third party. Any other reproduction or display of these resources is strictly prohibited. You shall fully indemnify Huaguan Semiconductor and its agents against any claims, damages, costs, losses, and liabilities arising from your use of these resources. Huaguan Semiconductor shall not be held responsible.