

E		F	
修 订 REV NO	标 记 MARK	修 改 描 要 REVISION DESCRIPTION	签 名 SIGNATURE
		NEW DWG	
			日期 DATE 2016-03-12

NOTE:

- MATERIAL SPECIFICATION:
 - HOUSING: HIGH TEMPERATURE RESISTANT PLASTIC, UL94 V-0.
 - CONTACTS: COPPER ALLOY
- PLATING SPECIFICATION:
 - CONTACTS:
 - Ni 50u" MIN. UNDER PLATED OVER ALL.
 - Au PLATED ON THE FUNCTIONAL AREA OF CONTACT. (GOLD PLATING THICKNESS FOLLOW THE P/N)
 - GOLD FLASH PLATING ON SOLDER AREA
 - FRONT SHELL:
 - Ni 30u" MIN. UNDER PLATED OVER ALL.
- MECHANICAL PERFORMANCE,
 - INSERTION FORCE: 0.5~2.0kgf.
 - REMOVAL FORCE: 0.8kgf~2.0kgf.
 - DURABILITY: 3000 CYCLES.
- ELECTRICAL PERFORMANCE,
 - CURRENT RATING: 5.0A
VOLTAGE RATING: 20V
 - INSULATION RESISTANCE: 100MΩ MIN
 - DIELECTRIC WITHSTAND VOLTAGE, AC 100V FOR 1 MINUTE.
 - LOW CONTACT RESISTANCE: INITIAL 40MΩ / AFTER 50MΩ
- ENVIRONMENTAL PERFORMANCE:
 - OPERATING TEMPERATURE: -30°C~+80°C.
- IR REFLOW:
 - THE PEAK TEMPERATURE ON THE BOARD SHALL BE MAINTAINED FOR 10 SECONDS AT 260°C.

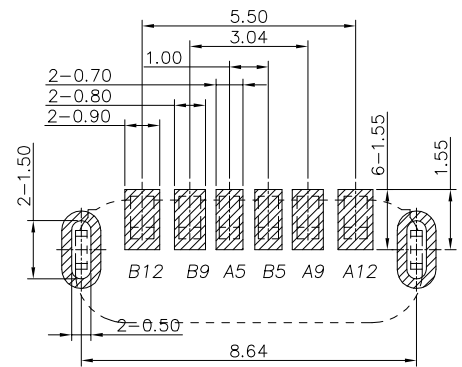
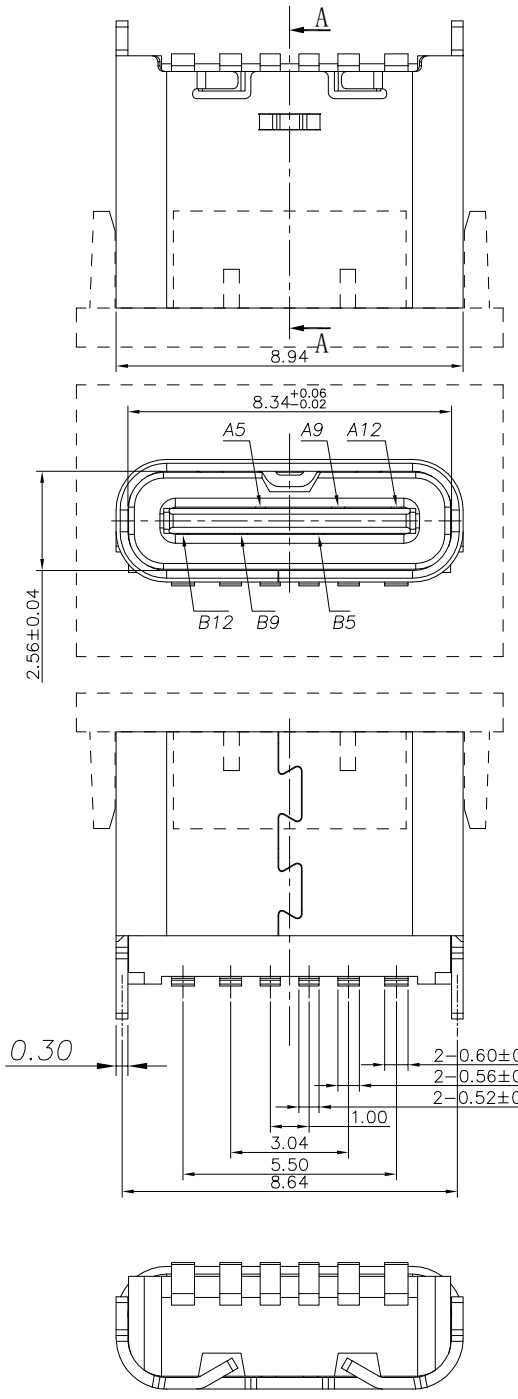
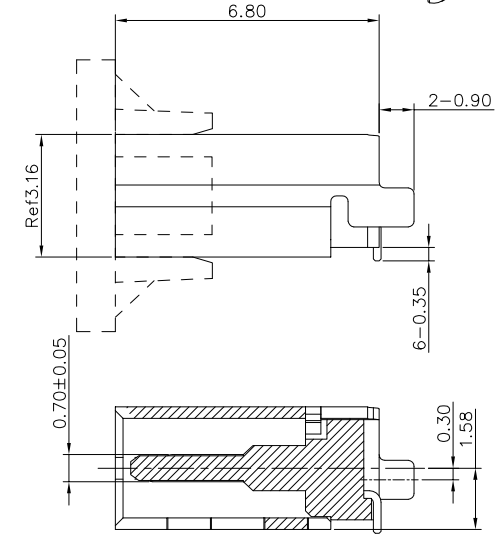
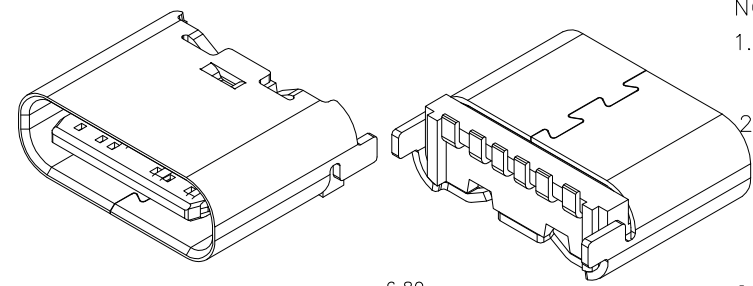

RECOMMEND P.C.B LAYOUT (COMPONENT SIDE)
TOLERANCE FOR PCB LAYOUT IS ± 0.05

USB TYPE-C PIN ASSIGNMENTS

PIN NUMBER	SIGNAL NAME
A5	CC1
A9	VBUS
A12	GND
B12	GND
B9	VBUS
B5	CC2



深圳市华德共创科技有限公司
Shenzhen Huade co-create Technology Co., LTD
电话: 0755-27111216 传真: 0755-29940187

-TOLERANCES- UNLESS OTHERWISE SPECIFIED 公差参数表		TITLE: 产品名称: TYPE C 6 PIN 立式SMT型H=6.8	
X.X ±0.30	X.X* ±3°	APPD: 核准:	PART NO: 产品编号: TYPE C-DB-105PWB
X.XX ±0.20	X.XX* ±2°	CHECK: 校对: 王建业	DATE
X.XXX ±0.10	X.XXX* ±1°	DRAW: 绘图: 黄艳兰	SCALE
			UNIT
		2016-03-12	CODE NUMBER
		1:1	A001
		mm	

修订 REV NO	标记 MARK	修改摘要 REVISION DESCRIPTION	签名 SIGNATURE	日期 DATE
		NEW DWG		2016-03-12

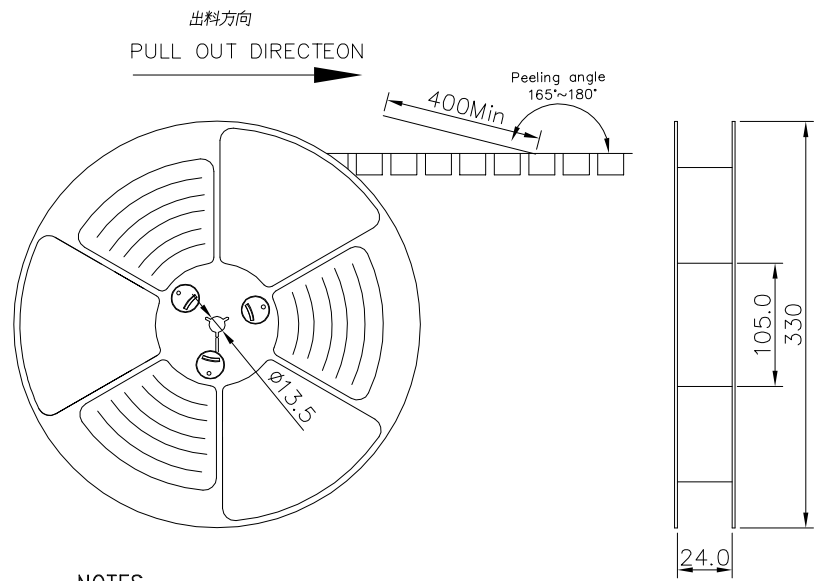

NOTES

1. 帶子引導長度
LEAD TAPE LENGTH
出料方向
PULL OUT DIRECTEON

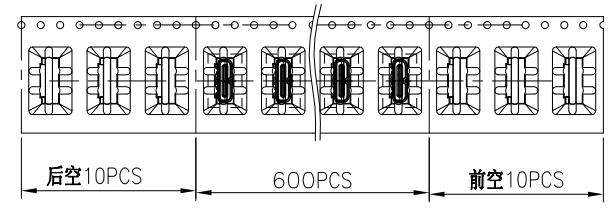

2. 上帶 剝力力為: 0.1~1.3N(10.2gf~130gf)
PEELING OFF FORCE OF TOP TAPE: 0.1~1.3N(10.2gf~130gf)
出貨運輸過程中一定注意:
THIS REQUIREMENT SHOULD BE APPLIED AT SHIPMENT:
卷帶在運輸過程中不能散開
PEELING OFF SHOULD NOT BE ALLOWED DURING TRANSPORTATION

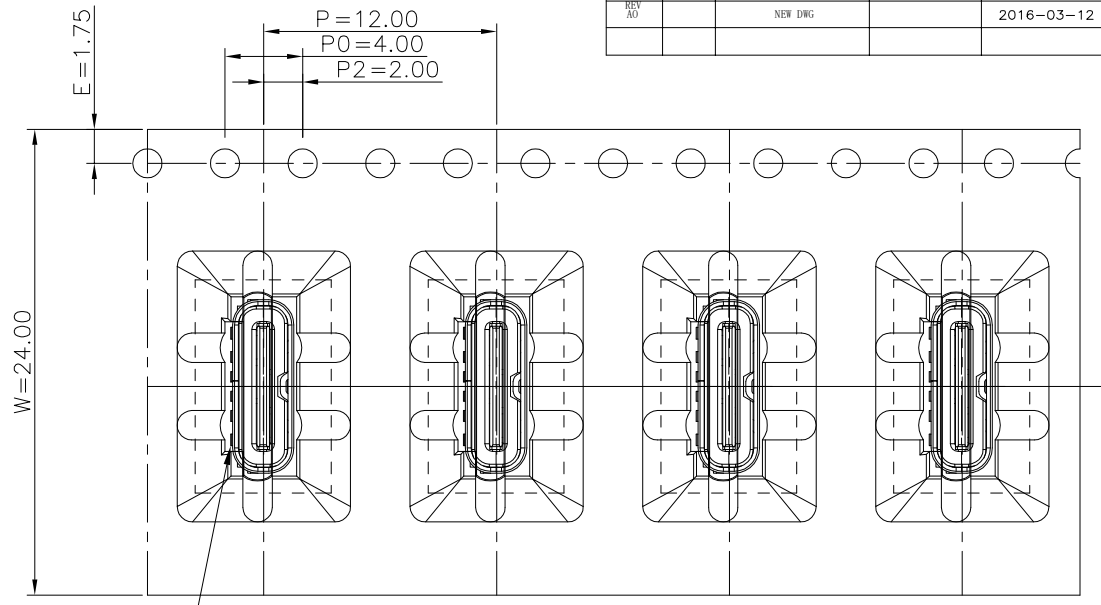

焊脚插左

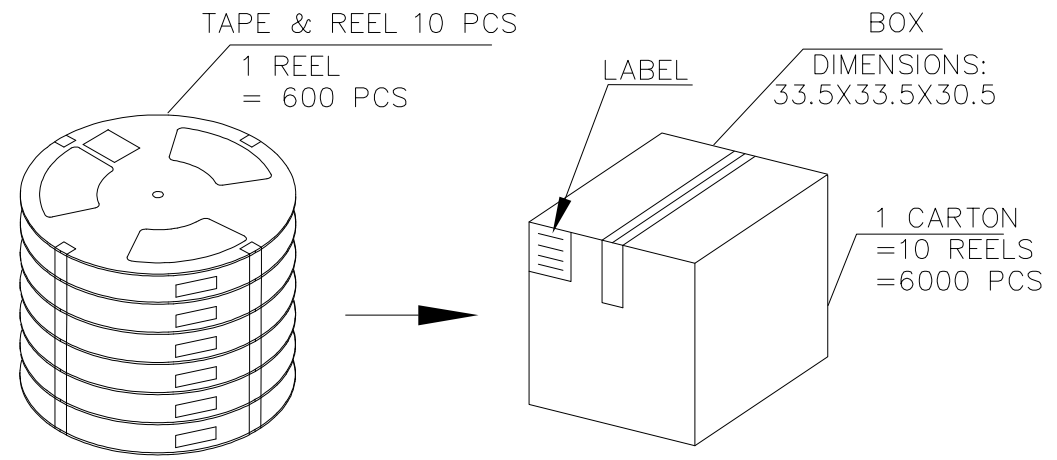

包裝明細表 (The detail of the packing) Carton						
產品料號 (Product No.)	包裝容量 (Packing Capacity)			重量 Weight (Kg)		
	pcs/box	boxs/Carton	Pcs/Box	N.W./Pcs	N.W./Box	G.W./Box
UCR04-X063X-10XR	600	10	6000	---	---	---

HDC 深圳市华德共创科技有限公司
Shenzhen Huade co-create Technology Co., LTD
电话: 0755-27111216 传真: 0755-29940187

-TOLERANCES- UNLESS OTHERWISE SPECIFIED 公差参数表		APPD: 核准:	TITLE: 产品名称: TYPE C 6 PIN 立式SMT型H=6.8			
X.X ±0.30	X.X* ±3°	CHECK: 校对: 王建业	PART NO: 产品编号: TYPE C-DB-105PWB			
X.XX ±0.20	X.XX* ±2°	DRAW: 绘图: 黄艳兰	DATE	SCALE	UNIT	CODE NUMBER
X.XXX ±0.10	X.XXX* ±1°		2016-03-12	1:1	mm	A001