

REVISIONS					
REV.	ECN NO.	LOCATION	DESCRIPTION	DATE	DESIGN
A1	N/A		图面升级整理图面	2025.1.17	阿树
A2	N/A		产品料号变更	2026.01.16	阿树

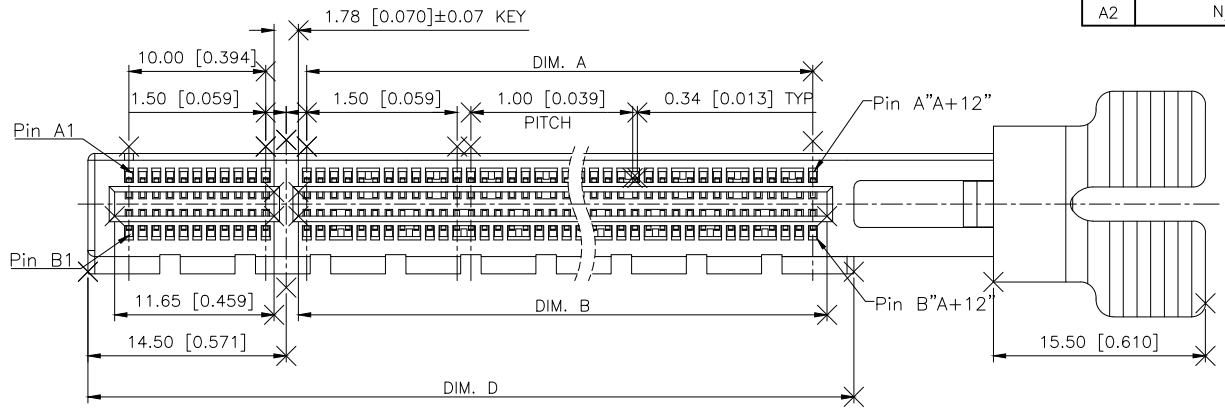

NOTES 备注:

- MATERIAL 材料:
  - HOUSING 胶壳: THERMOPLASTIC, HIGH TEMP, UL94V-0, COLOR: SEE PART NO.
  - LATCH 锁存器: THERMOPLASTIC, HIGH TEMP, UL94V-0, COLOR: SEE PART NO.
  - CONTACTS 端子: COPPER ALLOY.
  - DUMMY CARD 卡: THERMOPLASTIC, HIGH TEMP, UL94 V-0, COLOR: BLACK.
- FINISH 电镀:
  - CONTACT 端子: SELECTIVE GOLD PLATING ON THE CONTACT AREA. 100μ" MIN. MATTE-TIN PLATING ON THE SOLDER TAILS, 50μ" MIN. NICKEL UNDERPLATING OVERALL.

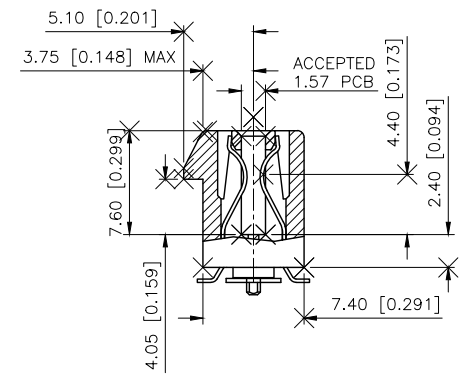
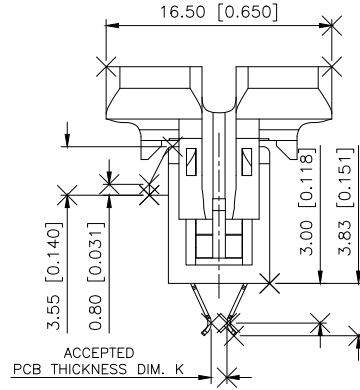
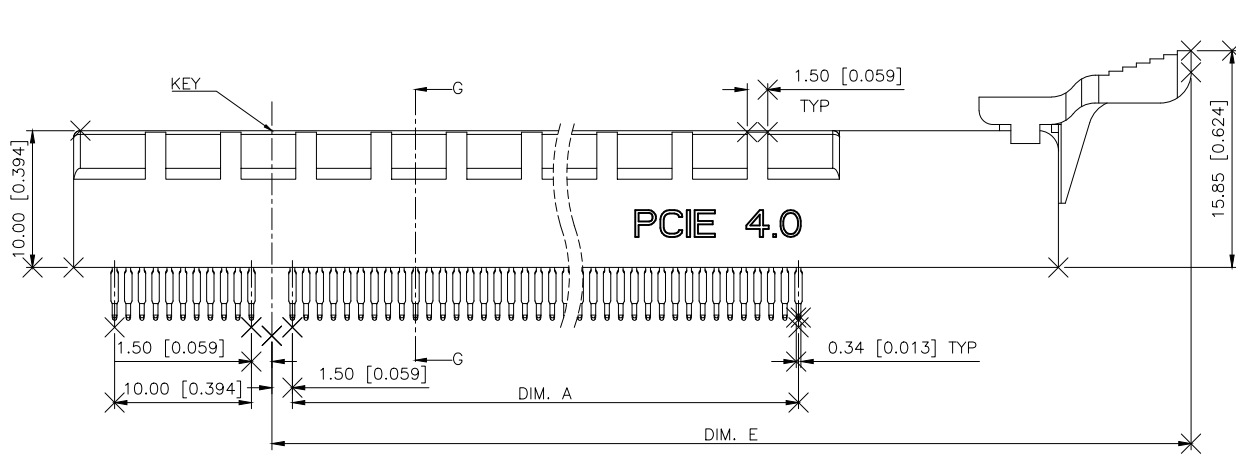

PART NO.:  
 X1622 W S-64 D-9T V01  
 ① ② ③ ④ ⑤ ⑥ ⑦

- ①Series No
- ②Category:W-Wafer
- ③Welding Board Angle : Straddle
- ④No.of Pins: 36~164 Pin
- ⑤DIM.M:A=2.08; B=2.30; C=1.80;D=1.57;
- ⑥lastic material: PA9T /PA46 UL94V-0
- ⑦Contact Plating:V15-Gold 15u"  
V30-Gold 30u"

PCB Thickness "DIM. K"	DIMENSIONS				
	POSITION	A±0.20	B±0.20	D±0.25	E±0.55
A	36	6	7.65	25	36.2
B	64	20	21.65	39	50.2
C	98	37	38.65	56	67.2
D	164	70	71.65	89	100.2

AuGLAR	±5°
X.	±0.40
X.x	±0.30
X.xx	±0.20
X.xxx	±0.15
UNSPECIFIED TOLERANCES	



DESIGN	阿树	VIEW:	MODEL TYPE:
CHECKED		UNIT: mm/in	PART NO.:
APPROVED		SIZE: A4	X1622WS-64D-9TV15
			DWG NO.:
			X-X1622WS-64D-9TV15

XKB INDUSTRIAL PRECISION CO.,LIMITED

SCALE	PAGE	REVISION
N/A	1/3	A2

REVISIONS					
REV.	ECN NO.	LOCATION	DESCRIPTION	DATE	DESIGN
A1	N/A		图面升级整理图面	2025.1.17	阿树
A2	N/A		产品料号变更	2026.01.16	阿树

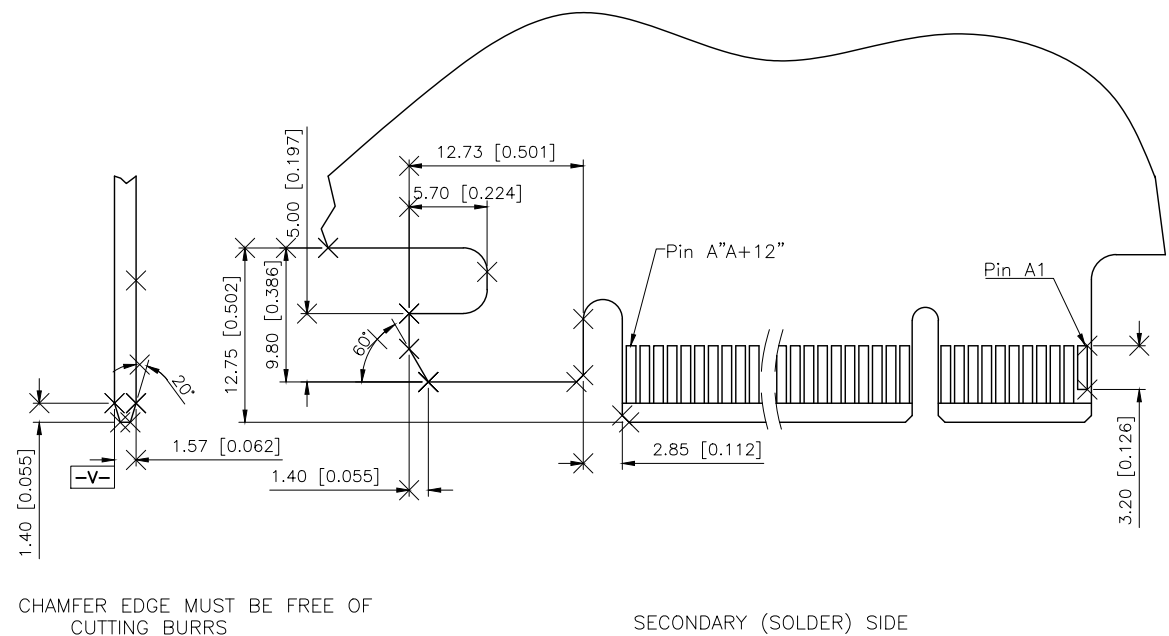
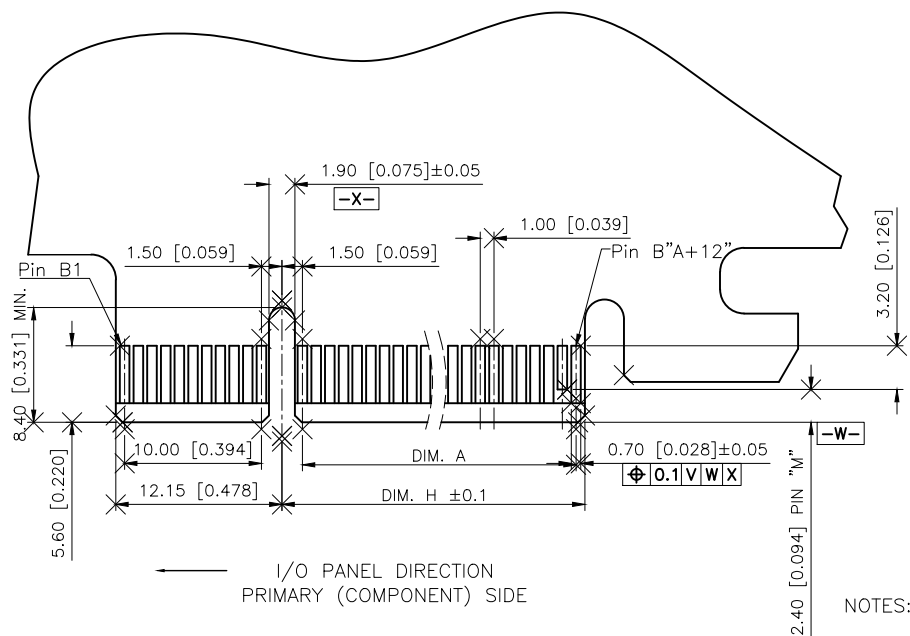

NOTES: CHAMFER EDGE MUST BE FREE OF CUTTING BURRS

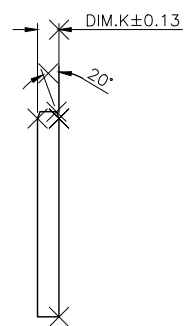
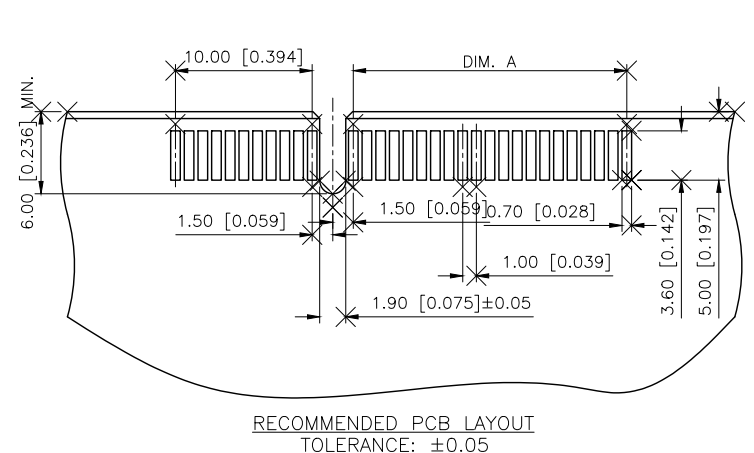

POS	DIM. A	DIM. H	"M"
36	6	8.15	B17
64	20	22.15	B31
98	37	39.15	B48
164	70	72.15	B81

AuGLAR	±5°
X.	±0.40
X.x	±0.30
X.xx	±0.20
X.xxx	±0.15
UNSPECIFIED TOLERANCES	



DESIGN	阿树	VIEW:		MODEL TYPE:	/
CHECKED		UNIT:	mm/in	PART NO.:	X1622WS-64D-9TV15
APPROVED		SIZE:	A4	DWG NO.:	X-X1622WS-64D-9TV15

XKB INDUSTRIAL PRECISION CO., LIMITED

SCALE	PAGE	REVISION
N/A	2/3	A2

REVISIONS					
REV.	ECN NO.	LOCATION	DESCRIPTION	DATE	DESIGN
A1	N/A		图面升级整理图面	2025.1.17	阿树
A2	N/A		产品料号变更	2026.01.16	阿树

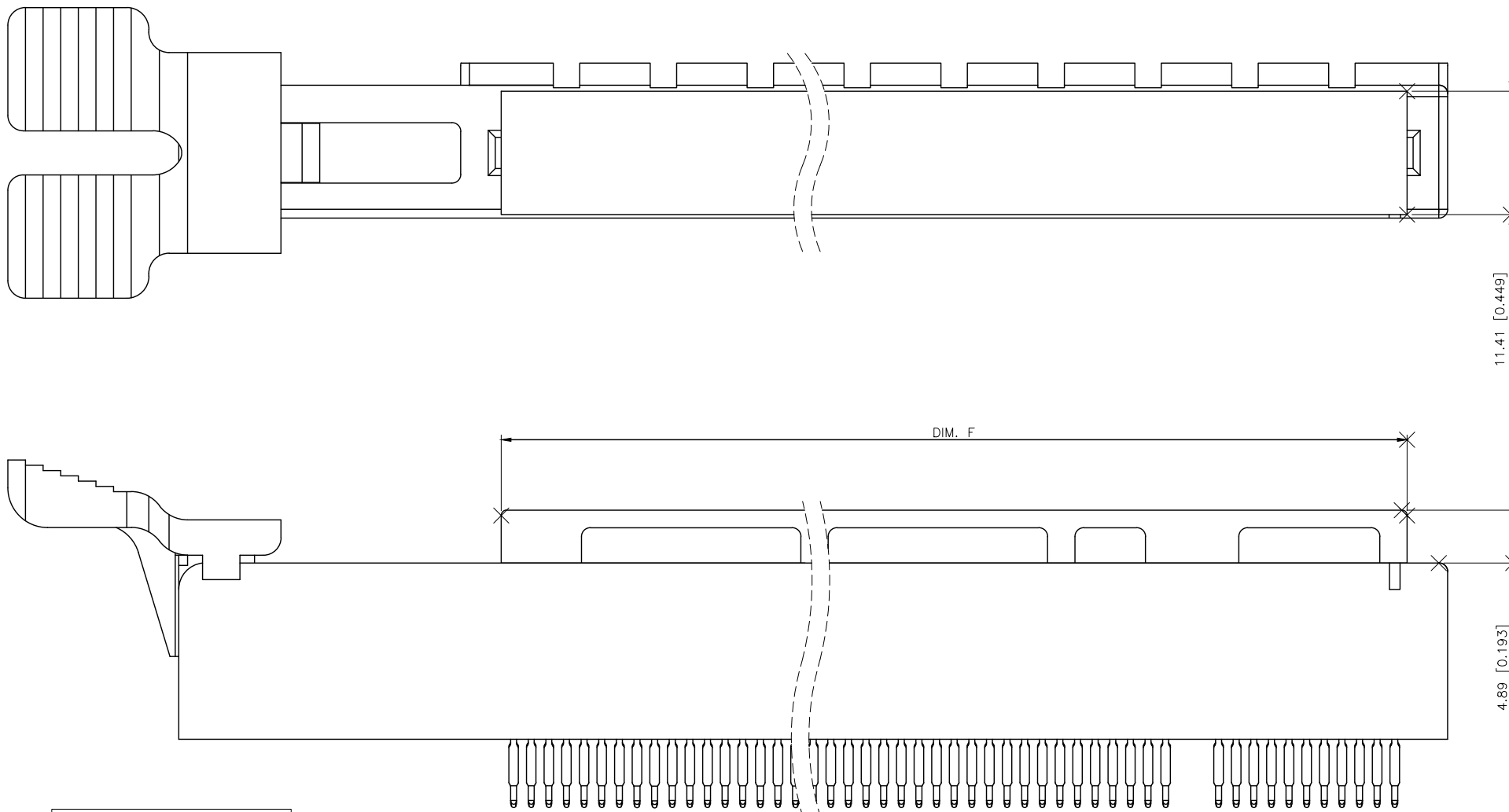

DIMENSIONS	
POSITION	DIM. F
36	20.4
64	34.4
98	51.4
164	84.4

WITH Dummy Card

AuGLAR	±5°
X.	±0.40
X.x	±0.30
X.xx	±0.20
X.xxx	±0.15
UNSPECIFIED TOLERANCES	



DESIGN	阿树	VIEW:	MODEL TYPE: /
CHECKED		UNIT: mm/in	PART NO.: X1622WS-64D-9TV15
APPROVED		SIZE: A4	DWG NO.: X-X1622WS-64D-9TV15