



样品承认书

Specification For Approval

| | |
|---------------------------|----------------|
| 客户名称 Customer Name | |
| 品 名 Variety | 有源电磁式贴片蜂鸣器 |
| 型 号 Part No | SMD-0955-05-27 |
| 客户型号 The customer Part No | |
| 样品日期 Model Date | |

客户承认签署

| | | |
|----------------------|---------------------|----------------------|
| 签定结果: | | |
| 核准/ <i>Approved:</i> | 审核/ <i>Checked:</i> | 经办/ <i>Designed:</i> |
| | | |

海旭确认签署

| | | |
|----------------------|---------------------|----------------------|
| 核准/ <i>Approved:</i> | 审核/ <i>Checked:</i> | 经办/ <i>Designed:</i> |
| 丁爱勇 | 黄锡梅 | 梁嘉敏 |

承认后请签回一份! *Thank you very much!*

公司地址: 广东省佛山市顺德区容桂社区细滘路 81 号中建创科园 C2 栋 7 楼

TEL: 0757-22907220

Email: ZShaixu@163.com Web: <http://www.haixucn.com/>

型号 part No: SMD-0955-05-27

性能参数 Electrical Characteristics

| | | | |
|----|--|--|-------|
| 1 | 额定电压 Rated Voltage (V0-p) |  | 5 |
| 2 | 工作电压 Operating Voltage (V0-p) | | 3~6 |
| 3 | *在 10cm 处测试声压值 *Sound Output at 10cm (dB) | ≥85(取最小值) | |
| 4 | *消耗电流 Current Consumption (mA) | ≤30 | |
| 5 | 共振频率 Resonant Frequency (Hz) | 2700 | |
| 6 | 线圈电阻 Coil Resistance (Ω) | 65±5 | |
| 7 | 工作温度 Operating Temperature (°C) | -20~+80 | |
| 8 | 储存温度 Storage Temperature (°C) | -30~+80 | |
| 9 | 单品重量 Weight (g) | 0.8 | |
| 10 | 外壳材料 Housing Material | 绿色-LCP 材料 Green-LCP material | |
| 11 | 环保要求 Environmental Protection Regulation | RoHS | |
| 12 | 封装形式 Package potting(SOP) | 贴片 Patch | (SMD) |
| 13 | 产品尺寸 product size | 9.0×9.0×5.5mm (参见附图) | |
| 14 | 焊接方式 Welding method | 回流焊接 Reflow soldering | |

外形图 DIMENSIONS (UNIT: mm) 未标注公差按±0.05mm 计算 Tolerance: ±0.05mm Except Specified

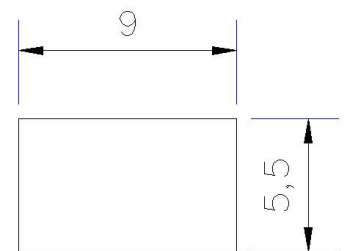
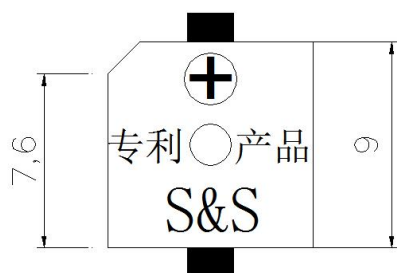
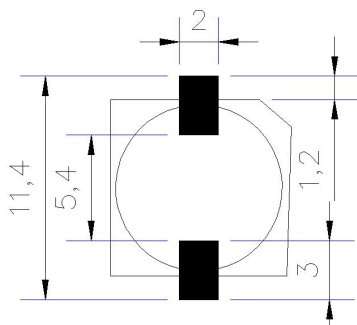

型号 part No: SMD-0955-05-27

可靠性测试 RELIABLY TEST

| 项目 ITEM | 测试条件 TESTING CONDITION | 试验后要求 VARIANCE AFTER TEST |
|----------------------------------|---|--|
| 高温试验 High Temperature Test | 放置 85±2℃ 96 小时，再室温放置 2 小时。 After being placed in a chamber with 85±2℃ for 96 hours and then being placed in natural condition for 2 hours. | 声压变化±10dB。 Allowable variation of SPL after test: ±10dB. |
| 低温试验 Low Temperature Test | 放置 -30±2℃ 96 小时，再室温放置 2 小时。 After being Placed in a chamber with -30±2℃ for 96 hours and then being placed in natural condition for 2 hours. | 声压变化±10dB。 Allowable variation of SPL after test: ±10dB. |
| 恒湿试验 Humidity Test | 存放在温度：60±5℃湿度：90%--95%的环境里 96 小时，然后放置到室温下放置 2 小时后测试。 Stored in the temperature humidity: 60±5℃ 90%--95% environment for 96 hours, and then placed into storage at room temperature for 2 hours after the test. | 声压变化±10dB。 Allowable variation of SPL after test: ±10dB. |
| Temperature Cycle Test 温度循环试验 | 放置 -30±2℃ 30 分钟、25℃±10℃放置 15 分钟，15 分钟后再将产品放入+85±2℃30 分钟、常温 25℃±10℃放置 15 分钟，20 个循环后放置常温下 2 小时。 After being placed in a chamber with -30±2℃ for 30 minutes, products shall be placed at room temperature(25℃±10℃).After 15 minutes at this temperature, products shall be placed in a chamber at +85±2℃.After 30 minutes at this temperature, products shall be return to room temperature (25℃±10℃) for15 minutes. After 20 above cycles, products shall be measured after being placed in natural condition for 2 hours. | 声压变化±10dB。 Allowable variation of SPL after test: ±10dB. |
| Drop Test 跌落试验 | 正面和侧面从 100mm 高度只有跌落在 4cm 厚度的木板上 3 次。 The front and side from a height of 100mm only drop in the 4cm thickness of theboard 3 times each. | 声压变化±10dB。 Allowable variation of SPL after test: ±10dB. |
| Vibration Test 振动试验 | After being applied vibration of amplitude of 1.5mm with 10 to 55 Hz band of vibration frequency to each of 3 perpendicular directions for 2 hours. 频率 10~55Hz, 振幅 1.5mm, 3 个方向, 振动 2 小时。 | 声压变化±10dB。 Allowable variation of SPL after test: ±10dB. |
| Solderability Test 可焊性试验 | Lead terminals are immersed in rosin for 5 seconds and then immersed in solder bath of 250±5℃ for 3±0.5 seconds (Except the edge of terminals). 端子在松香中浸入 5 秒并在 250±5℃锡中浸 3±0.5 秒 | 95% min. lead terminals shall be wet with solder 有 95%吃锡效果。 |

型号 part No: SMD-0955-05-27

交流状态下可靠性测试 RELIABLY TEST

| 项目 ITEM | 测试条件 TESTING CONDITION | 试验后要求 VARIANCE AFTER TEST |
|---------------------------------------|---|---|
| Continuous electricity test 连续通电试验 | Temperature: room temperature 25 °C Voltage: rated voltage 5 V Frequency: the rated frequency for 2.7 KHZ Time: 500 hours 温度: 室温 25°C 电压: 额定电压 5V, 频率: 额定频率 2.7KHz 时间: 500 小时 | 声压变化±10dB。 Allowable variation of SPL after test: ±10dB. |

Typical Frequency Response Curve (音频曲线图)

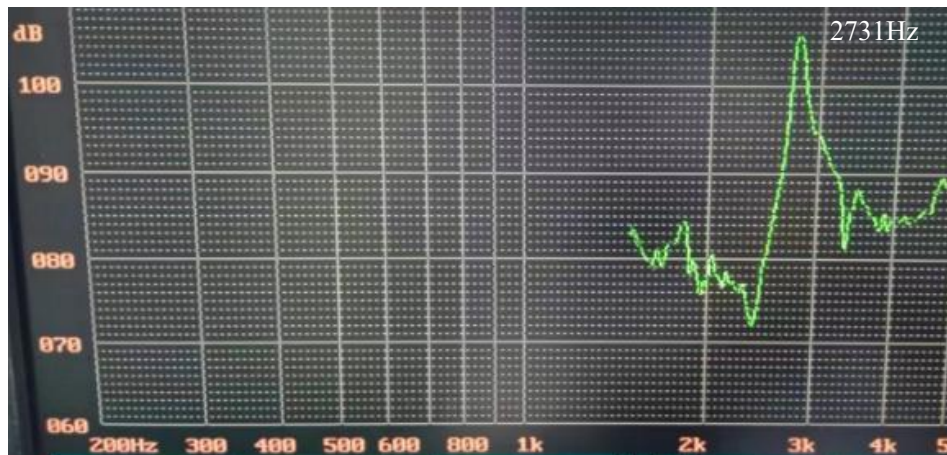

CRY6125 电声器件测试仪

型号 part No: SMD-0955-05-27

(测试方法) 直流状态下可靠性测试 TESTING METHOD



Standard Measurement conditions

Temperature: $25 \pm 2^\circ\text{C}$ Humidity: 45-65%

Acoustic Characteristics:

The oscillation frequency, current consumption and sound pressure are measured by the measuring instruments shown below

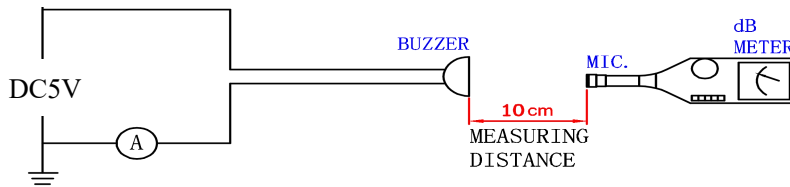

In the measuring test, buzzer is placed as follows:



图一



图二



图三



图四



XL-8 电声器件测试仪

型号 part No: SMD-0955-05-27

结构 structure

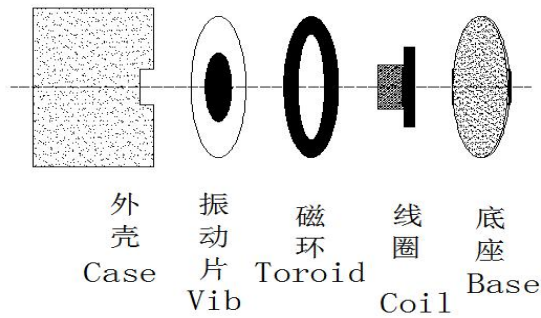

建议回焊炉温度

Recommended reflow temperature

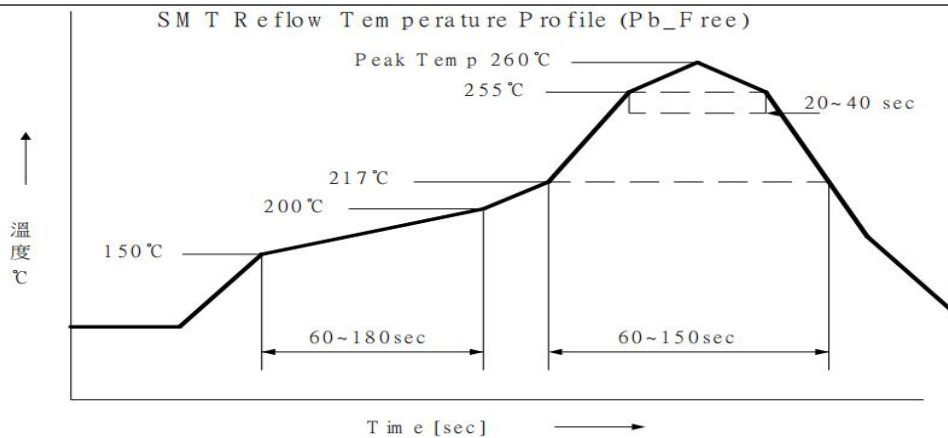

包装规格 packing specifications

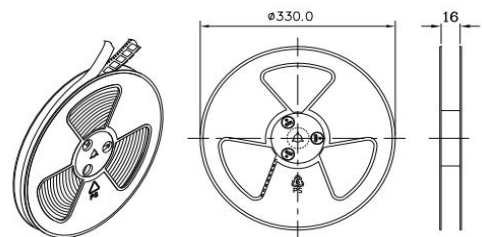

包装要求:

- 1、产品装袋前干燥处理后,再用防潮防静电真空包装袋(MBB)(真空包装)
- 2、包装数量:每箱10盒,每盒1盘,每盘500Pcs
- 3、内盒放检验报告和出货标签
- 4、包装应符合J-STD-033国际标准定义要求

Packaging Requirements:

- 1、The product shall undergo drying treatment prior to bagging, followed by vacuum packaging in moisture-proof and anti-static vacuum packaging bags (MBB).
- 2、Quantity: 10 boxes per carton, 1 tray per box, 500 pieces per tray.
- 3、Inspection reports and shipping labels shall be placed inside the inner boxes.
- 4、The packaging shall comply with the requirements defined in the international standard J-STD-033.

