

## 1. Description

These devices are precision timing circuits capable of producing accurate time delays or oscillation. In the time-delay or mono-stable mode of operation, the timed interval is controlled by a single external resistor and capacitor network. In the a-stable mode of operation, the frequency and duty cycle can be controlled independently with two external resistors and a single external capacitor.

## 3. Applications

- Fingerprint Biometrics
- Iris Biometrics

## 2. Features

- Timing From Microseconds to Hours
- Astable or Monostable Operation
- Adjustable Duty Cycle
- TTL-Compatible Output Can Sink or Source Up to 200 mA

- RFID Reader

## 4. Simplified Schematic

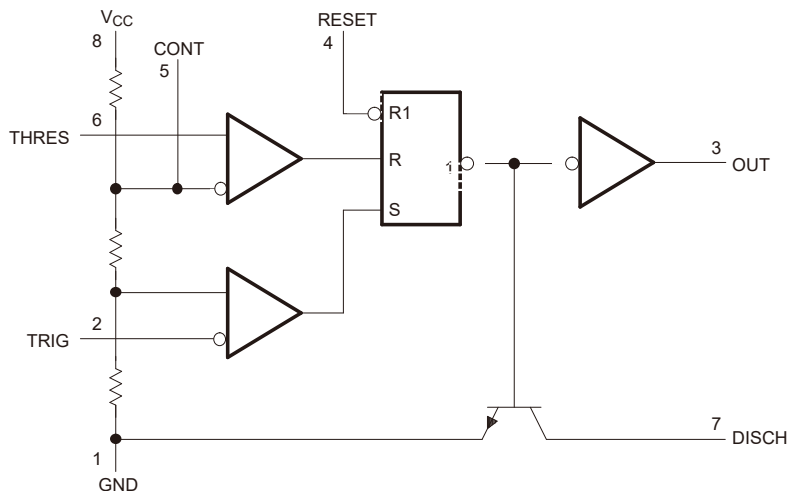



## 5. Device Information

Device Model	Working Temperature	Package
NE555	$T_A=0^{\circ}\text{C}$ to $70^{\circ}\text{C}$	DR (SOP-8)
		P (DIP-8)
SA555	$T_A=-40^{\circ}\text{C}$ to $85^{\circ}\text{C}$	DR (SOP-8)
		P (DIP-8)

## 6. Pinning Information

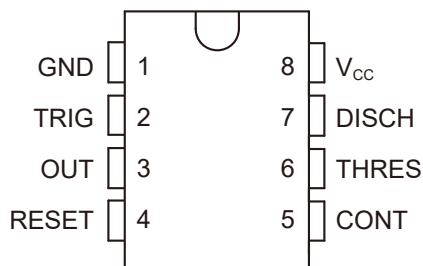

NE555... DR PACKAGE

SA555...P PACKAGE

### Pin Functions

Pin		I/O	Description
Name	DR/P		
CONT	5	I/O	Controls comparator thresholds, Outputs 2/3 VCC, allows bypass capacitor connection
DISCH	7	O	Open collector output to discharge timing capacitor
GND	1	-	Ground
OUT	3	O	High current timer output signal
RESET	4	I	Active low reset input forces output and discharge low
THRES	6	I	End of timing input. THRES > CONT sets output low and discharge low
TRIG	2	I	Start of timing input. TRIG < 1/2 CONT sets output high and discharge open
V <sub>CC</sub>	8	-	Input supply voltage, 4.5V to 16V.(SA555 maximum is 18V)



## 7. Absolute Maximum Ratings

Over operating free-air temperature range (unless otherwise noted)

Condition	Symbol	Min	Max	Unit
Supply voltage <sup>(2)</sup>	V <sub>CC</sub>		18	V
Input voltage (CONT, RESET, THRES, TRIG)	V <sub>I</sub>		V <sub>CC</sub>	V
Output current	I <sub>O</sub>		±225	mA
Package thermal impedance <sup>(3)(4)</sup>	DR package		97	°C
	P package		85	°C
Operating virtual junction temperature	T <sub>J</sub>		150	°C

(1) Stresses beyond those listed under Absolute Maximum Ratings may cause permanent damage to the device. These are stress ratings only, and functional operation of the device at these or any other conditions beyond those indicated under Recommended Operating Conditions is not implied. Exposure to absolute-maximum-rated conditions for extended periods may affect device reliability.

(2) All voltage values are with respect to GND.

(3) Maximum power dissipation is a function of T<sub>J(max)</sub>, θ<sub>JA</sub>, and T<sub>A</sub>. The maximum allowable power dissipation at any allowable ambient temperature is P<sub>D</sub> = (T<sub>J(max)</sub> - T<sub>A</sub>) / θ<sub>JA</sub>. Operating at the absolute maximum T<sub>J</sub> of 150°C can affect reliability.

(4) The package thermal impedance is calculated in accordance with JESD 51-7.

(5) Maximum power dissipation is a function of T<sub>J(max)</sub>, θ<sub>JC</sub>, and T<sub>C</sub>. The maximum allowable power dissipation at any allowable case temperature is P<sub>D</sub> = (T<sub>J(max)</sub> - T<sub>C</sub>) / θ<sub>JC</sub>. Operating at the absolute maximum T<sub>J</sub> of 150°C can affect reliability.

(6) The package thermal impedance is calculated in accordance with MIL-STD-883.



## 8. Handling Ratings

Parameter	Symbol	Min	Max	Units
Storage temperature range	$T_{STG}$	-65	150	°C

## 9. Recommended Operating Conditions

Over operating free-air temperature range (unless otherwise noted)

Condition		Symbol	Min	Max	Unit
Supply voltage	NE555, SA555	$V_{CC}$	4.5	16	V
Input voltage	CONT, RESET, THRES, and TRIG	$V_i$		$V_{CC}$	V
Output current		$I_o$		±200	mA
Operating free-air temperature	NE555	$T_A$	0	70	°C
	SA555		-40	85	°C



## 10. Electrical Characteristics

$V_{CC}=5V$  to  $15V$ ,  $T_A=25^{\circ}C$  (unless otherwise noted)

Parameter	Conditions	NE/SA555			Units
		Min	Typ	Max	
THRES voltage level	$V_{CC}=15V$	8.8	10	11.2	V
	$V_{CC}=5V$	2.4	3.3	4.2	V
THRES current <sup>(1)</sup>			30	250	nA
TRIG voltage level	$V_{CC}=15V$	4.5	5	5.6	V
	$V_{CC}=5V$	1.1	1.67	2.2	V
TRIG current	TRIG at 0V		0.5	2	$\mu A$
RESET voltage level		0.3	0.7	1	V
	$T_A=-55^{\circ}C$ to $125^{\circ}C$				V
RESET current	RESET at $V_{CC}$		0.1	0.4	mA
	RESET at 0 V		-0.4	-1.5	mA
DISCH switch off-state current			20	100	nA
DISCH switch on-state voltage	$V_{CC}=5V$ , $I_O=8mA$		0.15	0.4	V
CONT voltage (open circuit)	$V_{CC}=15V$	9	10	11	V
	$V_{CC}=5V$	2.6	3.3	4	V
High-level output voltage	$V_{CC}=15V$ , $I_{OH}=-100mA$	12.75	13.3		V
	$V_{CC}=15V$ , $I_{OH}=-200mA$		12.5		V
	$V_{CC}=5V$ , $I_{OH}=-100mA$	2.75	3.3		V
Low-level output voltage	$V_{CC}=15V$ , $I_{OL}=10mA$		0.1	0.25	V
	$V_{CC}=15V$ , $I_{OL}=50mA$		0.4	0.75	V
	$V_{CC}=15V$ , $I_{OL}=100mA$		2	2.5	V
	$V_{CC}=15V$ , $I_{OL}=200mA$		2.5		V
	$V_{CC}=5V$ , $I_{OL}=3.5mA$				V
	$V_{CC}=5V$ , $I_{OL}=5mA$		0.1	0.35	V
	$V_{CC}=5V$ , $I_{OL}=8mA$		0.15	0.4	V



Parameter	Conditions		NE/SA555			Units
			Min	Typ	Max	
Supply current	Output low, No load	$V_{CC}=15V$		10	15	mA
		$V_{CC}=5V$		3	6	mA
	Output high, No load	$V_{CC}=15V$		9	13	mA
		$V_{CC}=5V$		2	5	mA

(1) This parameter influences the maximum value of the timing resistors  $R_A$  and  $R_B$  in the circuit of Figure 12. For example, when  $V_{CC}=5V$ , the maximum value is  $R = R_A + R_B \neq 3.4M\Omega$ , and for  $V_{CC}=15V$ , the maximum value is  $10M\Omega$ .



## 11. Operating Characteristics

$V_{CC}=5V$  to  $15V$ ,  $T_A=25^\circ C$  (unless otherwise noted)

Parameter		Conditions <sup>(1)</sup>	NE/SA555			Units
			Min	Typ	Max	
Initial error of timing interval <sup>(2)</sup>	Each timer, monostable <sup>(3)</sup>	$T_A=25^\circ C$		1	3	%
	Each timer, astable <sup>(5)</sup>			2.25		%
Temperature coefficient of timing interval	Each timer, monostable <sup>(3)</sup>	$T_A=MIN$ to $MAX$		50		ppm/
	Each timer, astable <sup>(5)</sup>			150		$^\circ C$
Supply-voltage sensitivity of timing interval	Each timer, monostable <sup>(3)</sup>	$T_A=25^\circ C$		0.1	0.5	%/V
	Each timer, astable <sup>(5)</sup>			0.3		%/V
Output-pulse rise time		$C_L=15pF$ , $T_A=25^\circ C$		100	300	ns
Output-pulse fall time		$C_L=15pF$ , $T_A=25^\circ C$		100	300	ns

(1) For conditions shown as MIN or MAX, use the appropriate value specified under recommended operating conditions.

(2) Timing interval error is defined as the difference between the measured value and the average value of a random sample from each process run.

(3) Values specified are for a device in a monostable circuit similar to Figure 9, with the following component values:  $R_A=2k\Omega$  to  $100k\Omega$ ,  $C=0.1\mu F$ .

(4) On products compliant to MIL-PRF-38535, this parameter is not production tested.

(5) Values specified are for a device in an astable circuit similar to Figure 12, with the following component values:  $R_A=1k\Omega$  to  $100k\Omega$ ,  $C=0.1\mu F$ .



## 12.1 Typical Characteristic

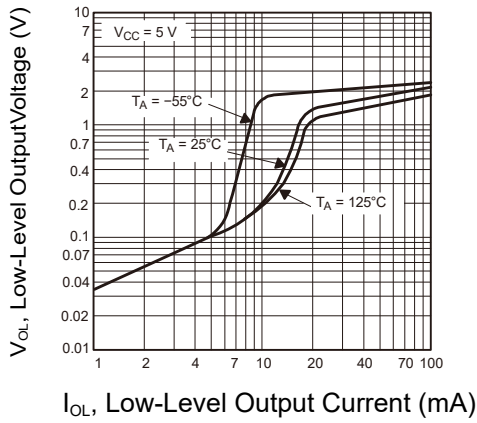

Figure 1: Low-Level Output Voltage vs Low-Level Output Current

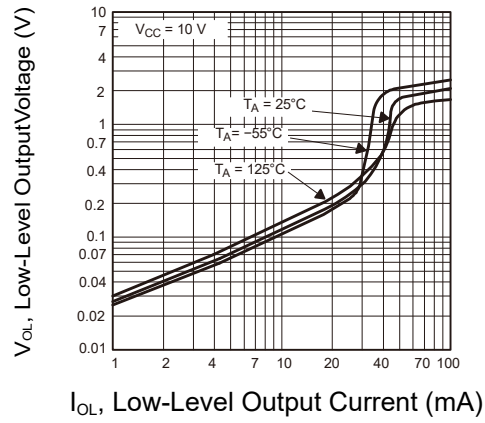

Figure 2: Low-Level Output Voltage vs Low-Level Output Current

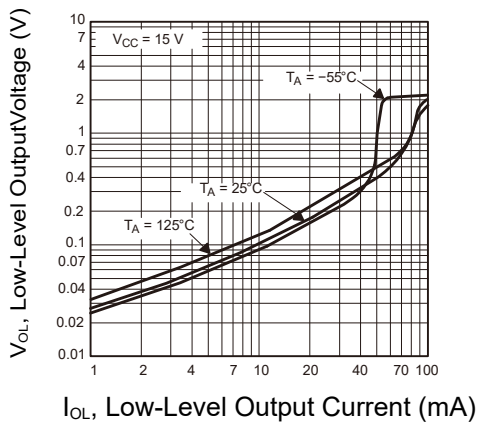

Figure 3: Low-Level Output Voltage vs Low-Level Output Current

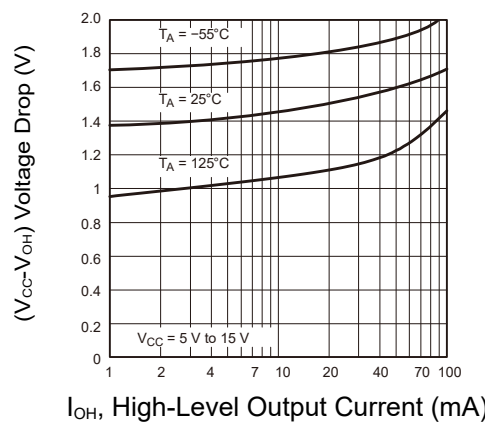

Figure 4: Drop Between Supply Voltage and Output vs High-Level Output Current

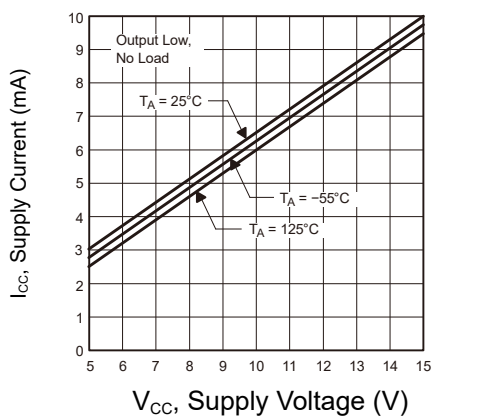

Figure 5: Supply Current vs Supply Voltage

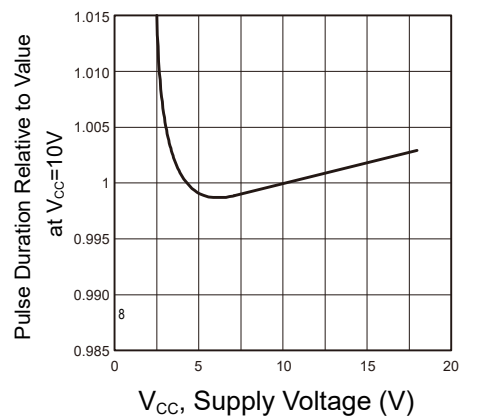
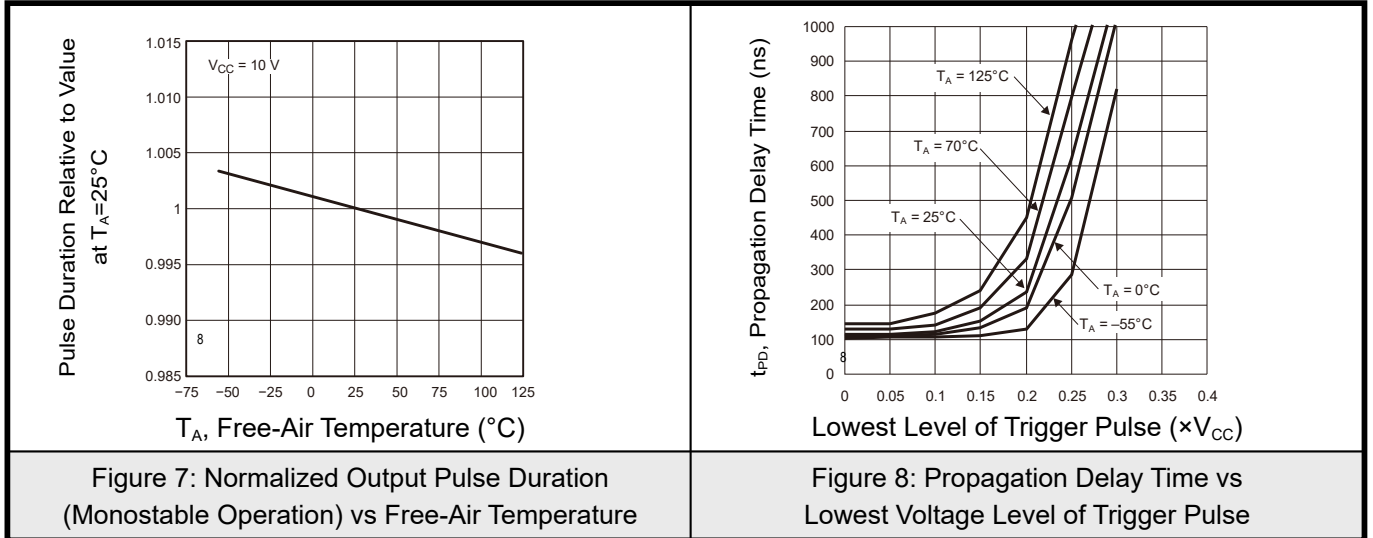

Figure 6: Normalized Output Pulse Duration (Monostable Operation) vs Supply Voltage



## 12.2 Typical Characteristic





## 13.Detailed Description

### Overview

The xx555 timer is a popular and easy to use for general purpose timing applications from 10 $\mu$ s to hours or from <1mHz to 100 kHz. In the time-delay or mono-stable mode of operation, the timed interval is controlled by a single external resistor and capacitor network. In the a-stable mode of operation, the frequency and duty cycle can be controlled independently with two external resistors and a single external capacitor. Maximum output sink and discharge sink current is greater for higher VCC and less for lower VCC.

### Functional Block Diagram

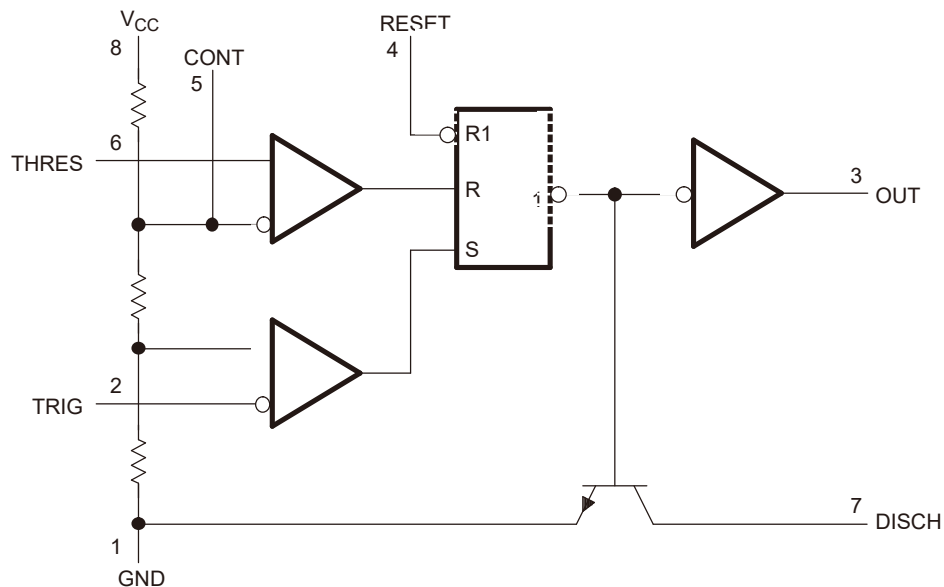

A. Pin numbers shown are for the D, JG, P, PS, and PW packages.

B. RESET can override TRIG, which can override THRES.



## 14. Feature Description

### Mono-stable Operation

For mono-stable operation, any of these timers can be connected as shown in Figure 9. If the output is low, application of a negative-going pulse to the trigger (TRIG) sets the flip-flop (Q goes low), drives the output high, and turns off Q1. Capacitor C then is charged through  $R_A$  until the voltage across the capacitor reaches the threshold voltage of the threshold (THRES) input. If TRIG has returned to a high level, the output of the threshold comparator resets the flip-flop (Q goes high), drives the output low, and discharges C through Q1.

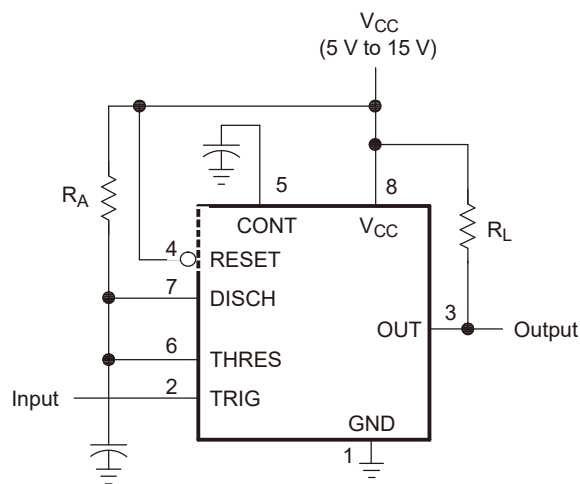

Pin numbers shown are for the D, JG, P, PS, and PW packages.

Figure 9. Circuit for Monostable Operation

Monostable operation is initiated when TRIG voltage falls below the trigger threshold. Once initiated, the sequence ends only if TRIG is high for at least  $10\ \mu\text{s}$  before the end of the timing interval. When the trigger is grounded, the comparator storage time can be as long as  $10\ \mu\text{s}$ , which limits the minimum monostable pulse width to  $10\ \mu\text{s}$ . Because of the threshold level and saturation voltage of Q1, the output pulse duration is approximately  $t_w = 1.1R_A C$ . Figure 11 is a plot of the time constant for various values of  $R_A$  and C. The threshold levels and charge rates both are directly proportional to the supply voltage,  $V_{CC}$ . The timing interval is, therefore, independent of the supply voltage, so long as the supply voltage is constant during the time interval. Applying a negative-going trigger pulse simultaneously to RESET and TRIG during the timing interval discharges C and reinitiates the cycle, commencing on the positive edge of the reset pulse. The output is held low as long as the reset pulse is low. To prevent false triggering, when RESET is not used, it should be connected to  $V_{CC}$ .

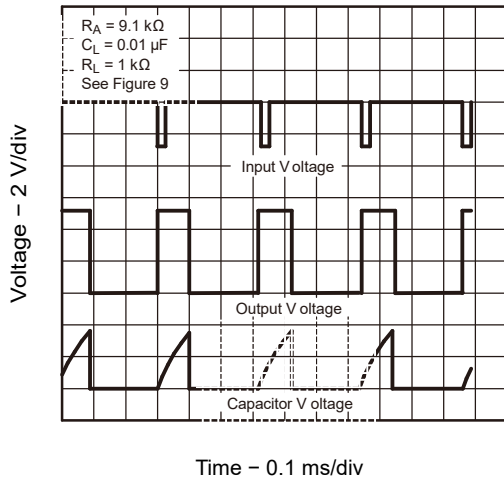

Figure 10: Typical Monostable Waveforms

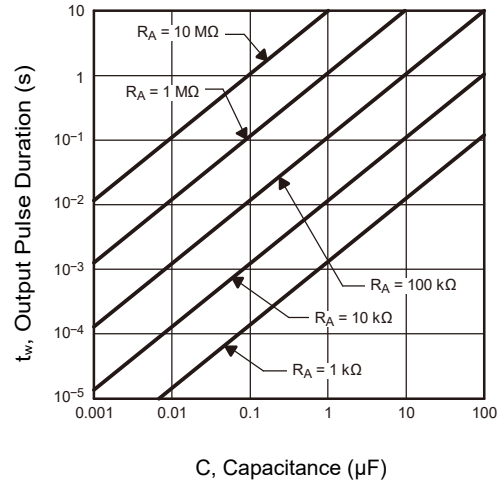
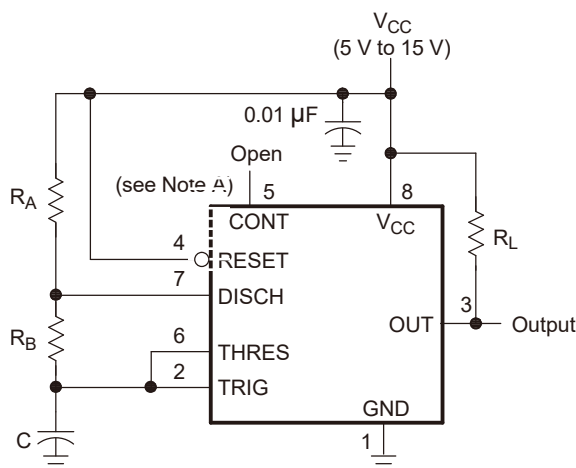

Figure 11: Output Pulse Duration vs Capacitance

### A-stable Operation

As shown in Figure 12, adding a second resistor,  $R_B$ , to the circuit of Figure 9 and connecting the trigger input to the threshold input causes the timer to self-trigger and run as a multi-vibrator. The capacitor  $C$  charges through  $R_A$  and  $R_B$  and then discharges through  $R_B$  only. Therefore, the duty cycle is controlled by the values of  $R_A$  and  $R_B$ . This astable connection results in capacitor  $C$  charging and discharging between the threshold-voltage level ( $\approx 0.67 \times V_{CC}$ ) and the trigger-voltage level ( $\approx 0.33 \times V_{CC}$ ). As in the mono-stable circuit, charge and discharge times (and, therefore, the frequency and duty cycle) are independent of the supply voltage.



Pin numbers shown are for the D, JG, P, PS, and PW packages.  
NOTE A: Decoupling CONT voltage to ground with a capacitor can improve operation. This should be evaluated for individual applications.

Figure 12: Circuit for Astable Operation

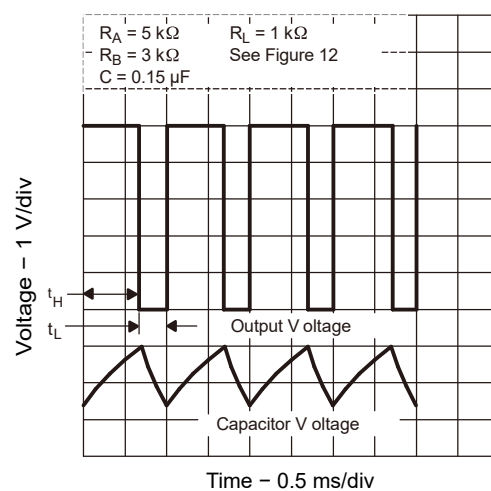

Figure 13: Typical Astable Waveforms



Figure 12 shows typical waveforms generated during astable operation. The output high-level duration  $t_H$  and low-level duration  $t_L$  can be calculated as follows:

$$t_H = 0.693 (R_A + R_B) C \quad (1)$$

$$t_L = 0.693 (R_B) C \quad (2)$$

Other useful relationships are shown below:

$$\text{period } t_H + t_L = 0.693 (R_A + 2R_B) C \quad (3)$$

$$\text{frequency} \approx \frac{1.44}{(R_A + 2R_B)C} \quad (4)$$

$$\text{Output driver duty cycle} = \frac{t_L}{t_H + t_L} = \frac{R_B}{R_A + 2R_B} \quad (5)$$

$$\text{Output waveform duty cycle} = \frac{t_H}{t_H + t_L} = 1 - \frac{R_B}{R_A + 2R_B} \quad (6)$$

$$\text{Low-to-high ratio} = \frac{t_L}{t_H} = \frac{R_B}{R_A + R_B} \quad (7)$$

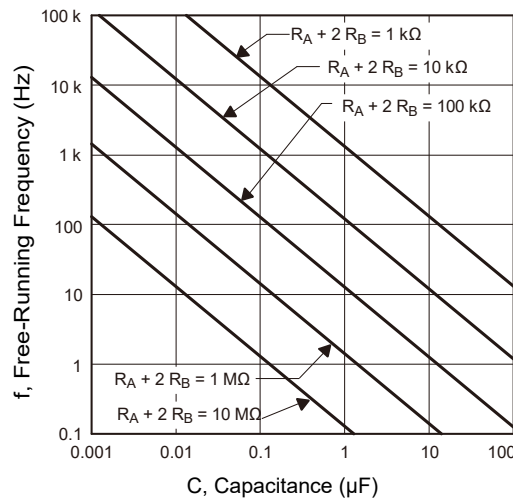

Figure 14: Free-Running Frequency



## Frequency Divider

By adjusting the length of the timing cycle, the basic circuit of Figure 9 can be made to operate as a frequency divider. Figure 15 shows a divide-by-three circuit that makes use of the fact that re-triggering cannot occur during the timing cycle.

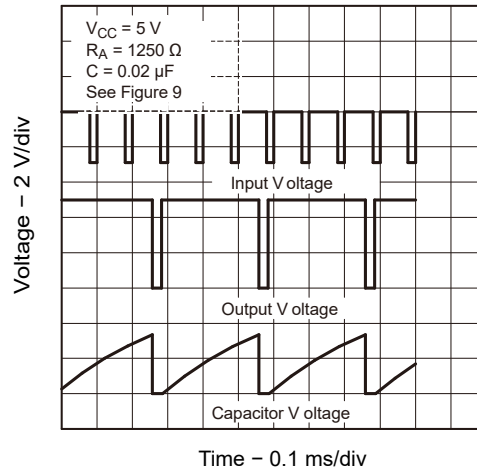

Figure 15: Divide-by-Three Circuit Waveforms

## 15.Device Functional Modes

Table 1. Function Table

Reset	Trigger Voltage <sup>(1)</sup>	Threshold Voltage <sup>(1)</sup>	Output	Discharge Switch
Low	Irrelevant	Irrelevant	Low	On
High	$<1/3 V_{CC}$	Irrelevant	High	Off
High	$>1/3 V_{CC}$	$>1/3 V_{CC}$	Low	On
High	$>1/3 V_{CC}$	$<1/3 V_{CC}$	As previously established	

(1) Voltage levels shown are nominal.



## Application Information

The xx555 timer devices use resistor and capacitor charging delay to provide a programmable time delay or operating frequency. This section presents a simplified discussion of the design process.

## 16. Typical Applications

### Missing-Pulse Detector

The circuit shown in Figure 16 can be used to detect a missing pulse or abnormally long spacing between consecutive pulses in a train of pulses. The timing interval of the monostable circuit is re-triggered continuously by the input pulse train as long as the pulse spacing is less than the timing interval. A longer pulse spacing, missing pulse, or terminated pulse train permits the timing interval to be completed, thereby generating an output pulse as shown in Figure 17.

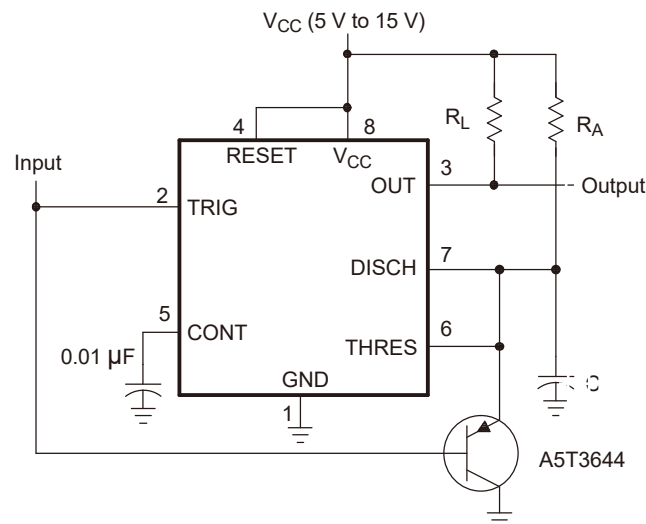

Pin numbers shown are shown for the D, JG, P, PS, and PW packages.

Figure 16: Circuit for Missing-Pulse Detector

### Design Requirements

Input fault (missing pulses) must be input high. Input stuck low will not be detected because timing capacitor "C" will remain discharged.

### Detailed Design Procedure

Choose  $R_A$  and  $C$  so that  $R_A \times C > [\text{maximum normal input high time}]$ .  $R_L$  improves  $V_{OH}$ , but it is not required for TTL compatibility.



## Application Curves

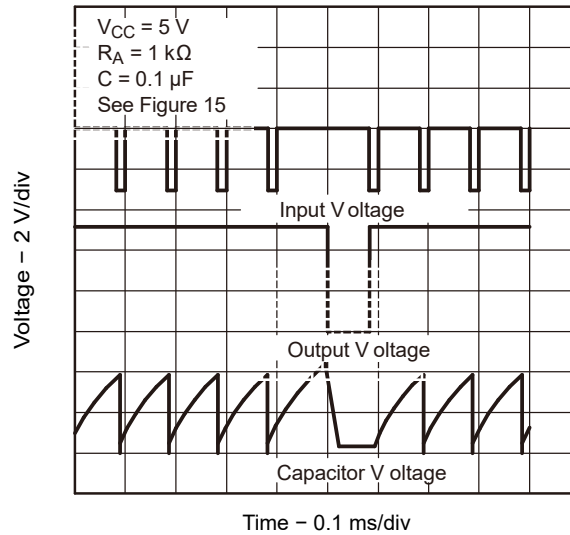
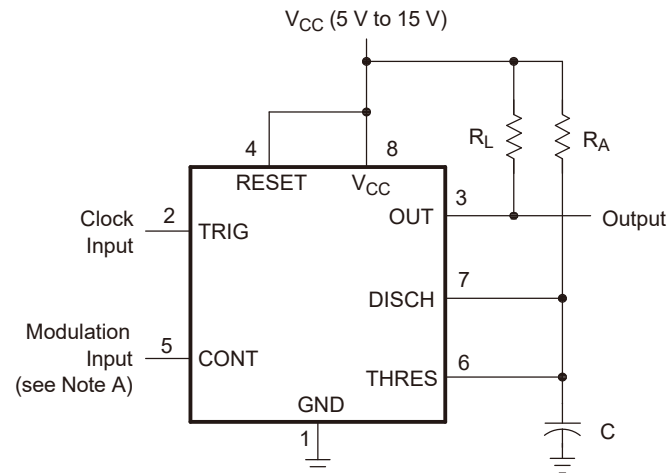

Figure 17: Completed Timing Waveforms for Missing-Pulse Detector

## Pulse-Width Modulation

The operation of the timer can be modified by modulating the internal threshold and trigger voltages, which is accomplished by applying an external voltage (or current) to CONT. Figure 18 shows a circuit for pulse-width modulation. A continuous input pulse train triggers the monostable circuit, and a control signal modulates the threshold voltage. Figure 19 shows the resulting output pulse-width modulation. While a sine-wave modulation signal is shown, any wave shape could be used.



Pin numbers shown are for the D, JG, P, PS, and PW packages.

NOTE A: The modulating signal can be direct or capacitively coupled to CONT. For direct coupling, the effects of modulation source voltage and impedance on the bias of the timer should be considered.

Figure 18: Circuit for Pulse-Width Modulation

### Design Requirements

Clock input must have  $V_{OL}$  and  $V_{OH}$  levels that are less than and greater than  $1/3 V_{CC}$ . Modulation input can vary from ground to  $V_{CC}$ . The application must be tolerant of a nonlinear transfer function; the relationship between modulation input and pulse width is not linear because the capacitor charge is based RC on an negative exponential curve.

### Detailed Design Procedure

Choose  $R_A$  and  $C$  so that  $R_A \times C = 1/4$  [clock input period].  $R_L$  improves  $V_{OH}$ , but it is not required for TTL compatibility.



## Application Curves

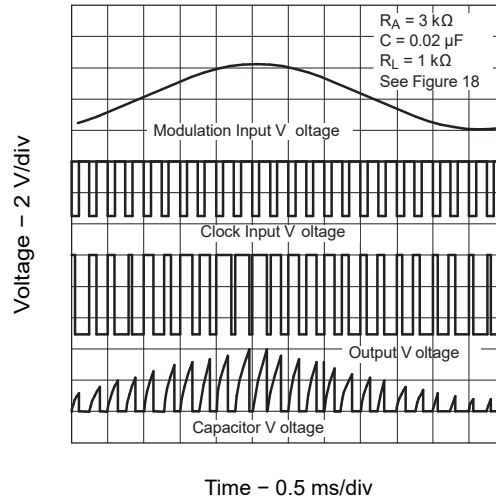
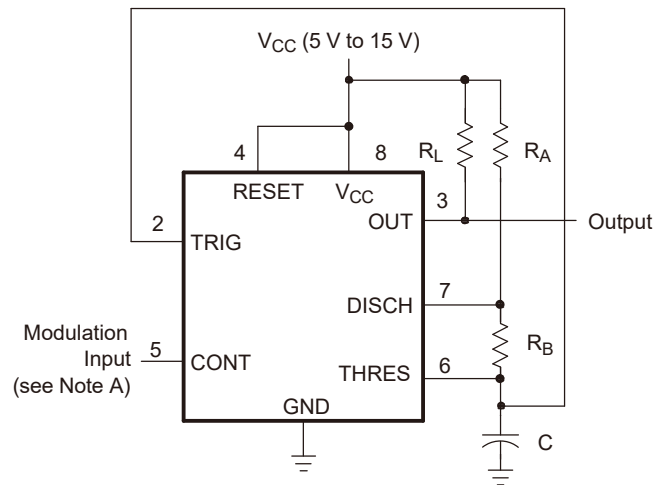

Figure 19: Pulse-Width-Modulation Waveforms

### Pulse-Position Modulation

As shown in Figure 20, any of these timers can be used as a pulse-position modulator. This application modulates the threshold voltage and, thereby, the time delay, of a free-running oscillator. Figure 21 shows a triangular-wave modulation signal for such a circuit; however, any wave shape could be used.



Pin numbers shown are for the D, JG, P, PS, and PW packages.

NOTE A: The modulating signal can be direct or capacitively coupled to CONT. For direct coupling, the effects of modulation source voltage and impedance on the bias of the timer should be considered.

Figure 20: Circuit for Pulse-Position Modulation

### Design Requirements

Both DC and AC coupled modulation input will change the upper and lower voltage thresholds for the timing capacitor. Both frequency and duty cycle will vary with the modulation voltage.

### Detailed Design Procedure

The nominal output frequency and duty cycle can be determined using formulas in A-stable Operation section.  $R_L$  improves  $V_{OH}$ , but it is not required for TTL compatibility.



## Application Curves

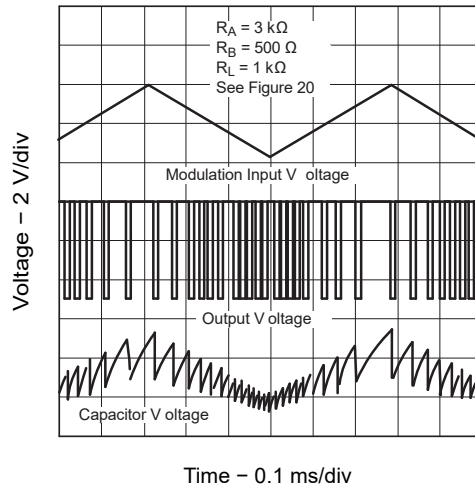
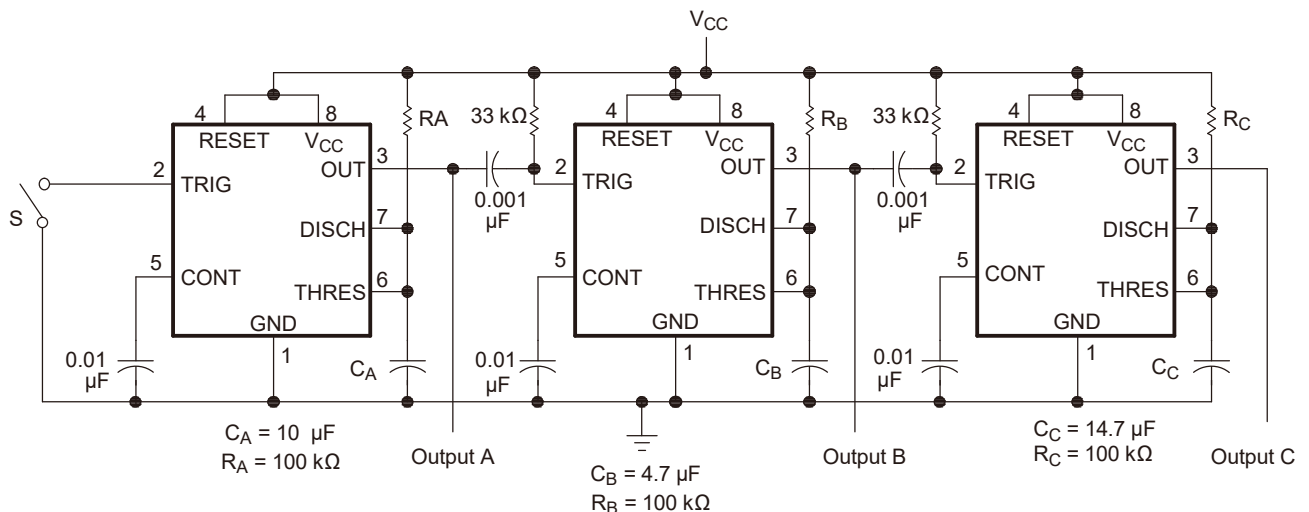

Figure 21: Pulse-Position-Modulation Waveforms

## Sequential Timer

Many applications, such as computers, require signals for initializing conditions during start-up. Other applications, such as test equipment, require activation of test signals in sequence. These timing circuits can be connected to provide such sequential control. The timers can be used in various combinations of astable or monostable circuit connections, with or without modulation, for extremely flexible waveform control. Figure 22 shows a sequencer circuit with possible applications in many systems, and Figure 23 shows the output waveforms.



Pin numbers shown are for the D, JG, P, PS, and PW packages.  
NOTE A: S closes momentarily at  $t = 0$ .

Figure 22: Sequential Timer Circuit



## Design Requirements

The sequential timer application chains together multiple mono-stable timers. The joining components are the 33kΩ resistors and 0.001-μF capacitors. The output high to low edge passes a 10-μs start pulse to the next monostable.

## Detailed Design Procedure

The timing resistors and capacitors can be chosen using this formula.  $t_w = 1.1 \times R \times C$ .

## Application Curves

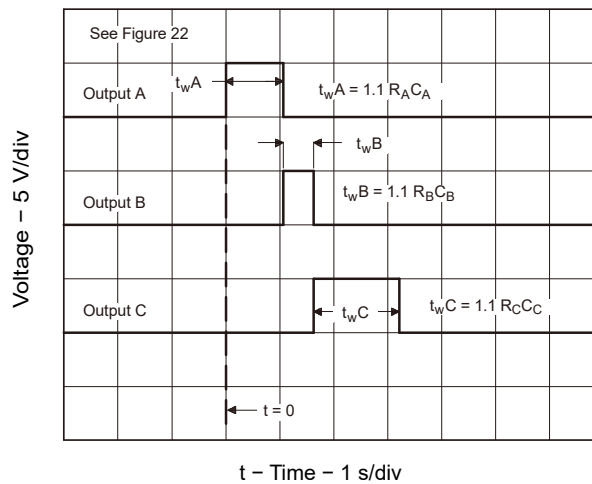

Figure 23: Sequential Timer Waveforms

## Power Supply Recommendations

The devices are designed to operate from an input voltage supply range between 4.5 V and 16 V. (18 V for SE555). A bypass capacitor is highly recommended from VCC to ground pin; ceramic 0.1 μF capacitor is sufficient.



## 17.SOP-8 Package Outline Dimensions

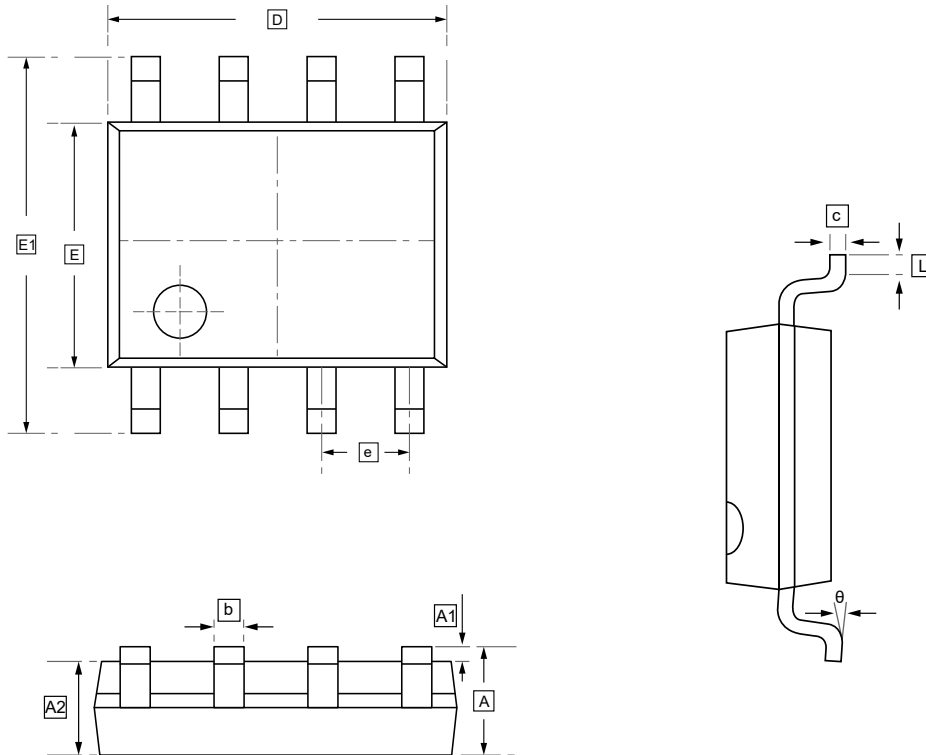

### DIMENSIONS (mm are the original dimensions)

Symbol	A	A1	A2	b	c	D	E	E1	e	L	θ
Min	1.350	0.000	1.350	0.330	0.170	4.700	3.800	5.800	1.270	0.400	0°
Max	1.750	0.100	1.550	0.510	0.250	5.100	4.000	6.200	BSC	1.270	8°



## 18. Ordering Information

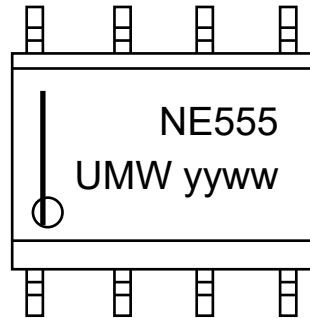

yy: Year Code  
ww: Week Code

Order Code	Marking	Package	Base QTY	Delivery Mode
UMW NE555DR	NE555	SOP-8	2500	Tape and reel
UMW SA555DR	SA555	SOP-8	2500	Tape and reel



## **19.Disclaimer**

UMW reserves the right to make changes to all products, specifications. Customers should obtain the latest version of product documentation and verify the completeness and currency of the information before placing an order.

When applying our products, please do not exceed the maximum rated values, as this may affect the reliability of the entire system. Under certain conditions, any semiconductor product may experience faults or failures. Buyers are responsible for adhering to safety standards and implementing safety measures during system design, prototyping, and manufacturing when using our products to prevent potential failure risks that could lead to personal injury or property damage.

Unless explicitly stated in writing, UMW products are not intended for use in medical, life-saving, or life-sustaining applications, nor for any other applications where product failure could result in personal injury or death. If customers use or sell the product for such applications without explicit authorization, they assume all associated risks.

When reselling, applying, or exporting, please comply with export control laws and regulations of China, the United States, the United Kingdom, the European Union, and other relevant countries, regions, and international organizations.

This document and any actions by UMW do not grant any intellectual property rights, whether express or implied, by estoppel or otherwise. The product names and marks mentioned herein may be trademarks of their respective owners.