

1 FEATURES

- Ultralow I_Q : 5 μ A
- Reverse Current Protection
- Low $I_{SHUTDOWN}$: 280nA
- Input Voltage Range: 4.5 V to 40 V
- Supports 250mA Peak Output
- 2% Accuracy Over Temperature
- Available in Fixed-Output Voltages:1.8V,2.5V,3.3V,5V
- Thermal Shutdown and Overcurrent Protection
- Packages: SOT23-5, SOT89-3,SOT23-3, SOT223, TO-252-3

2 APPLICATIONS

- Zigbee™ Networks
- Home Automation
- Metering
- Weighing Scales
- Portable Power Tools
- Remote Control Devices
- Wireless Handsets, Smart Phones, PDAs, WLAN,and Other PC Add-On Cards
- White Goods

3 DESCRIPTION

The GM73XX series products are available in fixed voltage versions of 1.8V, 2.5V, 3.3V, and 5V.

The GM73XX series of linear regulators are ultralow, quiescent current devices designed for power-sensitive applications. A precision band-gap and error amplifier provides 2% accuracy over temperature. Quiescent current of only 5 μ A makes these devices ideal solutions for battery-powered, always-on systems that require very little idle-state power dissipation. These devices have thermal-shutdown, current-limit, and reverse-current protections for added safety. Shutdown mode is enabled by pulling the EN pin low. The shutdown current in this mode goes down to 280nA, typical.

The GM73XX series is available in SOT89-3 ,SOT23-5, SOT23-3,SOT223 and TO-252-3 packages.

TYPICAL APPLICATION



Typical Application Circuit

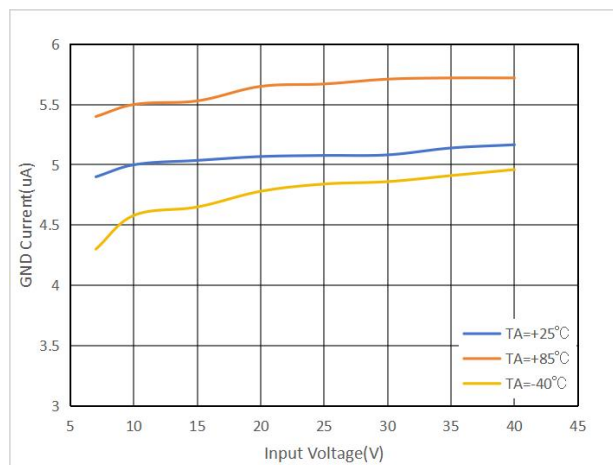

GND Current vs VIN and Temperature(V_{OUT}=5V)

4 PIN CONFIGURATION AND FUNCTIONS

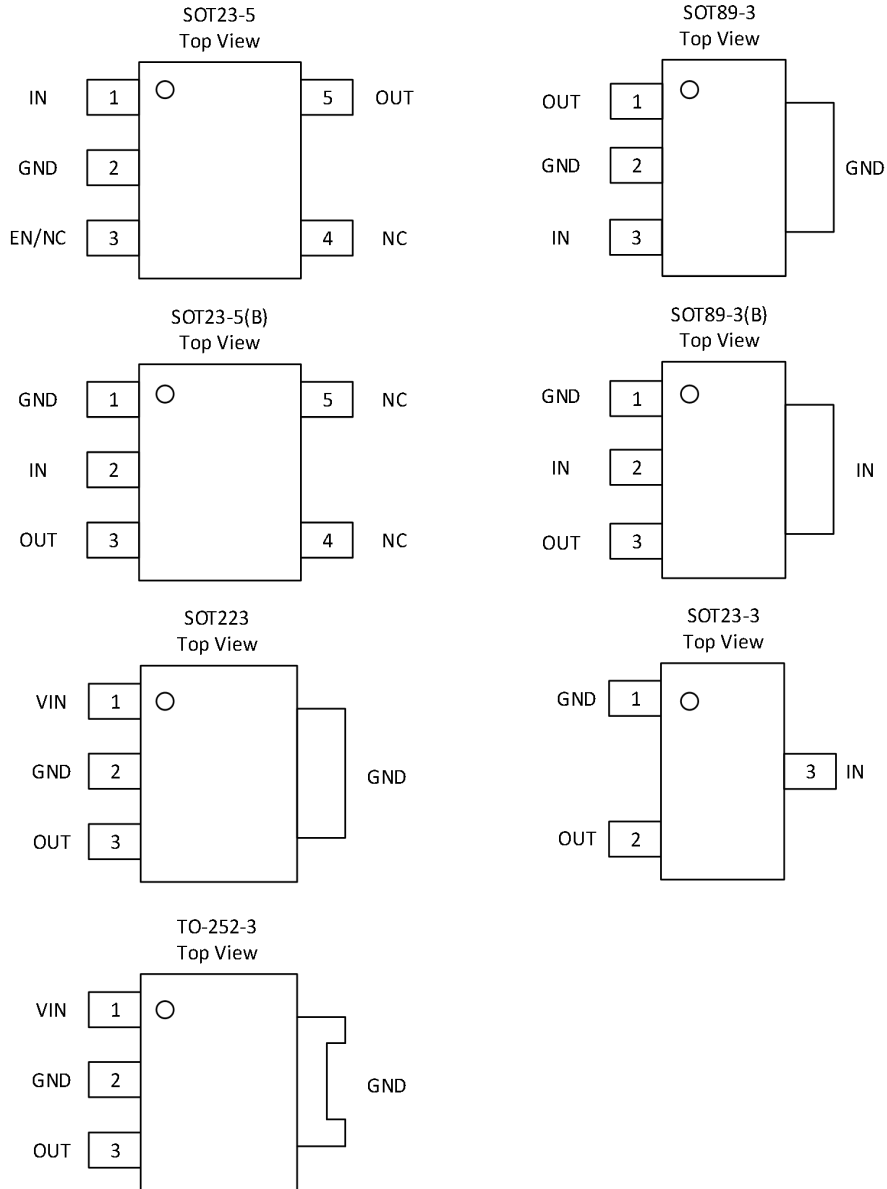

NAME	PIN NUMBER							I/O	DESCRIPTION
	SOT89-3	SOT89-3(B)	SOT23-5	SOT23-5(B)	SOT23-3	SOT223	TO-252-3		
IN	3	2	1	2	3	1	1	I	Input voltage pin.
NC	-	-	3,4	4,5	-	-	-	-	No connection.
OUT	1	3	5	3	2	3	3	O	Regulated output voltage pin
GND	2	1	2	1	1	2	2	-	Ground reference pin. Connect GND pin to PCB ground plane directly.
EN	-	-	3	-	-	-	-	I	Enable pin. Drive this pin high to enable the device. Drive this pin low to put the device into low current shutdown. This pin can be left floating to enable the device.

5 SEPCIFICATIONS

5.1 ABSOLUTE MAXIMUM RATINGS

SYMBOL	DESCRIPTION	MIN	MAX	UNIT
V_{IN}	Voltage	-0.3	45	V
V_{EN}		-0.3	45	
V_{OUT}		-0.3	7	
I_{OUT}	Maximum output current	Internally limited		
	Output short-circuit duration	Indefinite		
P_{DISS}	Continues total power dissipation	See Thermal Information		W
T_J	Operating junction temperature,TJ	-55	150	°C
T_{stg}	Storage temperature	-55	150	°C

(1) Stress beyond those listed under Absolute Maximum Ratings may cause permanent damage to the device. These are stress ratings only, which do not imply functional operation of the device at these or any other conditions beyond those indicated under Recommend Operating Conditions. Exposure to absolute-maximum-rated conditions for extended periods may affect device reliability.

5.2 ESD RATINGS

			VALUE	UNIT
$V_{(ESD)}$	Electrostatic discharge	Human body(HBM),per ANSI/ESDA/JEDEC JS-001	±2000	V
		Charged device model(CDM),per JEDEC specification JESD22-C101	±500	

(1) JEDEC document JEP155 states that 2kV HBM allows safe manufacturing with standard ESD control process.

(2) JEDEC document JEP157 states that 500V CDM allows safe manufacturing with a standard ESD control process.

6.3 RECOMMENDED OPERATING CONDITIONS

Over operating junction temperature range(unless otherwise noted)

SYMBOL	DESCRIPTION	MIN	NOM	MAX	UNIT
V_{IN}	Input voltage	4.5		40	V
V_{OUT}	Output voltage	1.8		5	V
V_{EN}	Enable voltage	0		40	V
T_J	Operating junction temperature	-40		125	°C

6.4 THERMAL INFORMATION

PACKAGE TYPE	θ_{JA}	θ_{JC}	UNIT
SOT89-3	63.0	9.41	°C/W
SOT89-3(B)	63.0	9.41	°C/W
SOT23-5	220	62	°C/W
SOT23-5(B)	220	62	°C/W
SOT23-3	220	62	°C/W
SOT223	60	15	°C/W
TO-252-3	37	15	°C/W

6.5 ELECTRICAL CHARACTERISTICS

At ambient temperature (T_A) = -40°C to $+85^{\circ}\text{C}$, $V_{IN} = V_{OUT(\text{typ})} + 1\text{V}$ or 2.7V (whichever is greater), $I_{OUT} = 1\text{mA}$, $V_{EN} = 2\text{V}$, and $C_{IN} = C_{OUT} = 2.2\mu\text{F}$ ceramic, unless otherwise noted. Typical values are at $T_A = 25^{\circ}\text{C}$.

SYMBOL	PARAMETER	TEST CONDITIONS	MIN	TYP	MAX	UNIT
V_{IN}	Input voltage range		4.5		40	V
V_{OUT}	Output voltage range		1.8		5	V
V_{OUT}	DC output accuracy		-2%		2%	
			-1%		1%	
ΔV_{OUT}	Line regulation	$V_{IN} = V_{OUT(\text{nom})} + 1\text{V}$ to 40V		3	10	mV
	Load regulation	$V_{IN} = V_{OUT(\text{typ})} + 1.5\text{V}$ or 3V (whichever is greater), $100\mu\text{A} \leq I_{OUT} \leq 250\text{mA}$		20	50	mV
V_{OD}	Dropout voltage ⁽¹⁾⁽²⁾	$I_{OUT} = 50\text{mA}$		200		mV
		$I_{OUT} = 100\text{mA}$		400		
		$I_{OUT} = 150\text{mA}$		700		
I_{CL}	Output current limit ⁽³⁾	$V_{OUT} = 0.9 \times V_{OUT(\text{NOM})}$	250	300	400	mA
I_{GND}	Ground pin current	$I_{OUT} = 0\text{mA}$		5	6	μA
		$I_{OUT} = 150\text{mA}$		350		
$I_{SHUTDOWN}$	Shutdown current	$V_{EN} \leq 0.4\text{V}$, $V_{IN} = 7\text{V}$		280		nA
PSRR	Power-supply rejection ratio	$f = 10\text{Hz}$		80		dB
		$f = 100\text{Hz}$		62		
		$f = 1\text{kHz}$		52		
V_n	Output noise voltage	$BW = 10\text{Hz}$ to 100kHz , $I_{OUT} = 10\text{mA}$, $V_{IN} = 2.7\text{V}$, $V_{OUT} = 1.2\text{V}$		190		μV_{RMS}
t_{STR}	Start-up time ⁽⁴⁾	$V_{OUT(\text{nom})} = 5\text{V}$		700	1000	μs
$V_{EN(\text{HI})}$	Enable pin high (enabled)		0.9			V
	Enable pin high (disabled)		0		0.4	V
UVLO	V_{IN} under-voltage lock-out	V_{IN} rising		4.5		V
I_{EN}	EN pin current	$EN = 1.0\text{V}$, $V_{IN} = 5.5\text{V}$		300		nA
t_{SD}	Thermal shutdown temperature	Shutdown, temperature increasing		158		$^{\circ}\text{C}$
		Reset, temperature decreasing		140		

(1) V_{DO} is measured with $V_{IN} = 0.98 \times V_{OUT(\text{nom})}$.

(2) Dropout is only valid when $V_{OUT} \geq 2.8\text{V}$ because of the minimum input voltage limits.

(3) Measured with $V_{IN} = V_{OUT} + 3\text{V}$ for $V_{OUT} \leq 2.5\text{V}$. Measured with $V_{IN} = V_{OUT} + 2.5\text{V}$ for $V_{OUT} > 2.5\text{V}$.

(4) Startup time = time from EN assertion to $0.95 \times V_{OUT(\text{nom})}$ and load = 47Ω .

6.6 TYPICAL CHARACTERISTICS

Over operating temperature range ($T_J = -40^{\circ}\text{C}$ to 85°C), $C_{OUT} = 2.2\mu\text{F}$, and $V_{IN} = V_{OUT(\text{typ})} + 1\text{V}$ or 2.7V (whichever is greater), unless otherwise noted. Typical values are at $T_J = 25^{\circ}\text{C}$.

5V Line Regulation vs VIN
VOUT=5V

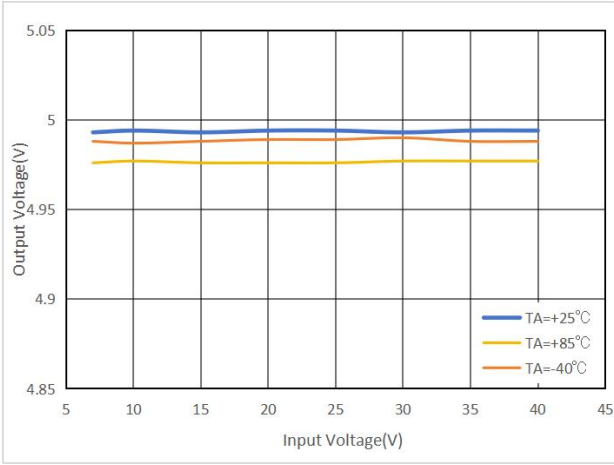

GND Current vs VIN and Temperature
VOUT=5V

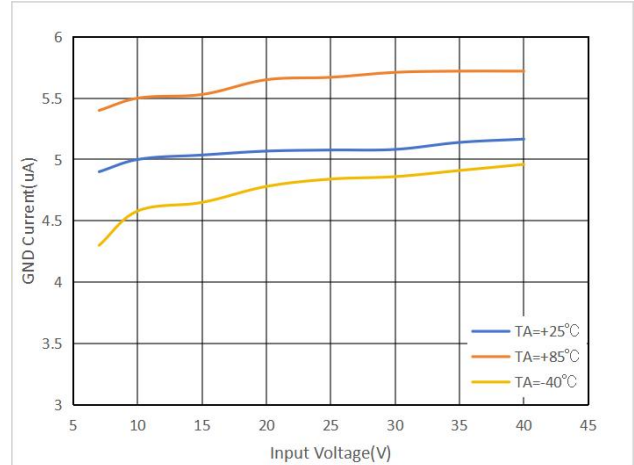

Load Transient (0mA to 50mA)

VIN=7V, VOUT=5V

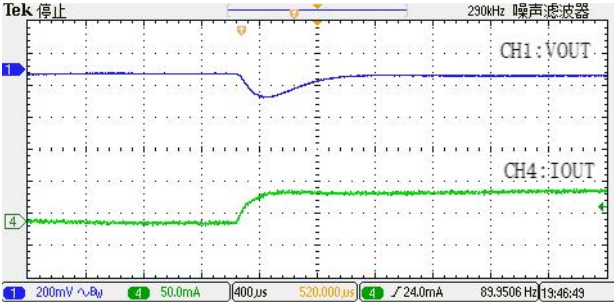

Load Transient (50mA to 0mA)

VIN=7V, VOUT=5V

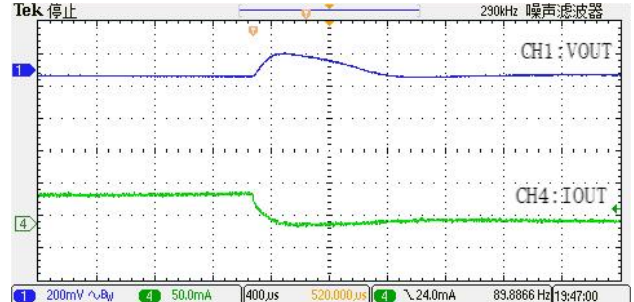

Load Transient (1mA to 150mA)

VIN=7V, VOUT=5V

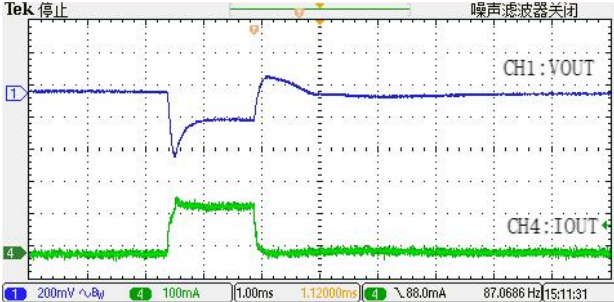

Load Transient (50mA to 150mA)

VIN=7V, VOUT=5V

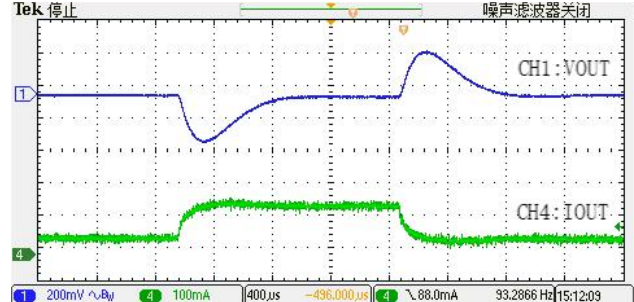

Power-up

VIN=7V, VOUT=5V

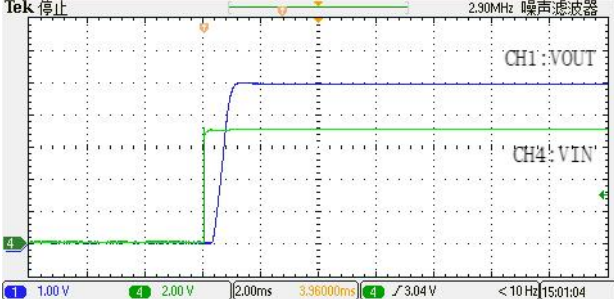

Line Transient (8V to 9V)

VOUT=5V, Iout=0mA

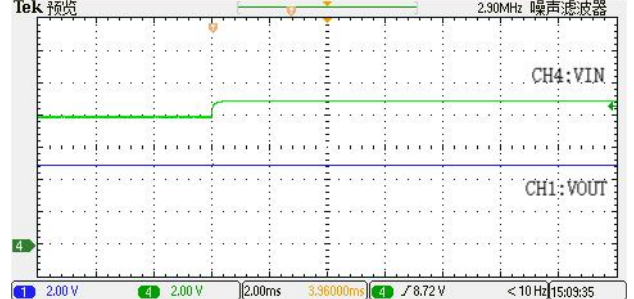

7 DETAILED DESCRIPTION

7.1 OVERVIEW

The GM73XX series products are available in fixed voltage versions of 1.8V, 2.5V, 3.3V, and 5V. The GM73XX series of devices are ultralow quiescent current, low-dropout (LDO) linear regulators. The GM73XX series offers reverse current protection to block any discharge current from the output into the input. The GM73XX series also features current limit and thermal shutdown for reliable operation.

7.2 FUNCTIONAL BLOCK DIAGRAM

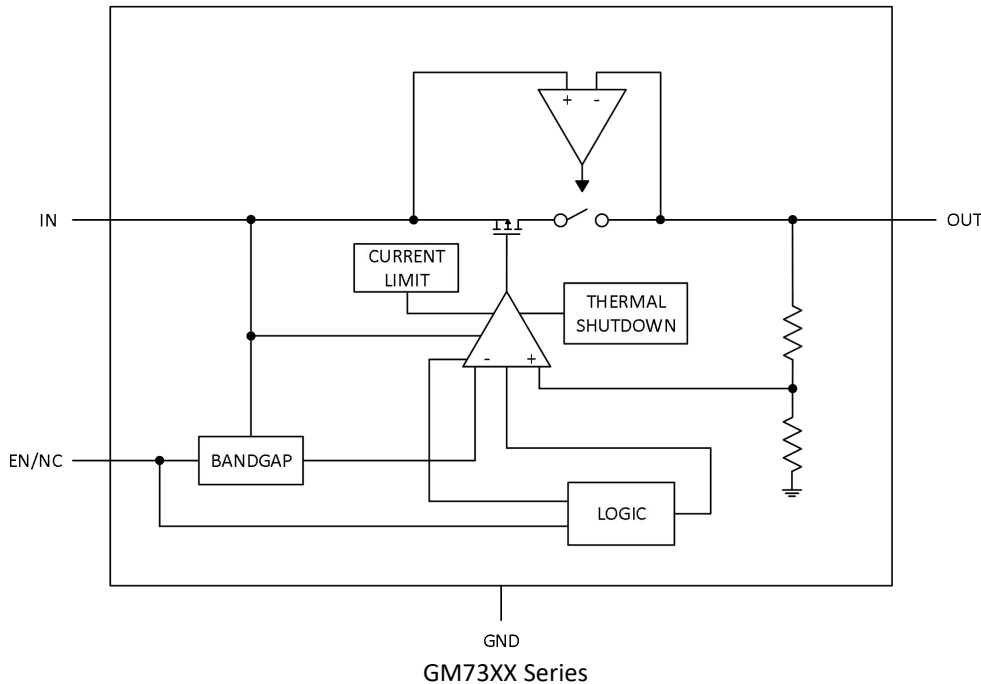

7.3 FEATURE DESCRIPTION

7.3.1 INTERNAL CURRENT LIMIT

The GM73XX internal current limit helps protect the regulator during fault conditions. During current limit, the output sources a fixed amount of current that is largely independent of output voltage. In such a case, the output voltage is not regulated, and can be measured as $(V_{OUT} = I_{LIMIT} \times R_{LOAD})$. The PMOS pass transistor dissipates $[(V_{IN} - V_{OUT}) \times I_{LIMIT}]$ until a thermal shutdown is triggered and the device turns off. When cool, the device is turned on by the internal thermal shutdown circuit. If the fault condition continues, the device cycles between current limit and thermal shutdown; see the Thermal Protection section for more details.

The GM73XX is characterized over the recommended operating output current range up to 200mA. The internal current limit begins to limit the output current at a minimum of 250mA of output current. The GM73XX continues to operate for output currents between 200mA and 250mA but some data sheet parameters may not be met.

7.3.2 DROPOUT VOLTAGE

The GM73XX use a PMOS pass transistor to achieve low dropout voltage. When $(V_{IN} - V_{OUT})$ is less than the dropout voltage (V_{DO}), the PMOS pass device is in the linear region of operation and the input-to-output resistance is the $R_{DS(ON)}$ of the PMOS pass element. V_{DO} approximately scales with the output current because the PMOS device functions like a resistor in dropout.

The ground pin current of many linear voltage regulators increases substantially when the device is operated in dropout. This increase in ground pin current while operating in dropout can be several orders of magnitude larger than when the device is not in dropout. The GM73XX employs a special control loop that limits the increase in ground pin current while operating in dropout. This functionality allows for the most efficient operation while in dropout conditions that can greatly increase battery run times.

7.3.3 UNDERVOLTAGE LOCKOUT (UVLO)

The GM73XX uses an undervoltage lockout (UVLO) circuit to keep the output shut off until the internal circuitry operates properly.

7.4 FEATURE DESCRIPTION

The GM73XX has the following functional modes:

1. Enabled: When the enable pin (EN) goes above 0.9V, the device is enabled. EN is pulled high by a 280nA current source; therefore, EN can be left floating to enable the device. Do not connect EN to VIN. The EN pin is clamped by a 6.5V Zener diode. Do not exceed the 7V absolute maximum rating on the enable pin or excessive current flowing into the Zener clamp will destroy the device.
2. Disabled: When EN goes below 0.4V, the device is disabled. During this time, OUT is high impedance and the current into IN ($I_{(SHUTDOWN)}$) is typically 280nA.

8 APPLICATION AND IMPLEMENTATION

8.1 APPLICATION INFORMATION

The GM73XX is a series of devices that belong to a new family of next-generation voltage regulators. These devices consume low quiescent current and deliver excellent line and load transient performance. This performance, combined with low noise and very good PSRR with little ($V_{IN} - V_{OUT}$) headroom, makes these devices ideal for RF portable applications, current limit, and thermal protection. The GM73XX series is specified from -40°C to $+85^{\circ}\text{C}$.

8.1.1 INPUT AND OUTPUT CAPACITOR

The GM73XX devices are stable with output capacitors with an effective capacitance of $2.0\mu\text{F}$ or greater for output voltages below 2.5V. For output voltages equal or greater than 2.5V, the minimum effective capacitance for stability is $1.5\mu\text{F}$. The maximum capacitance for stability is $47\mu\text{F}$. The equivalent series resistance (ESR) of the output capacitor must be between 0Ω and 0.2Ω for stability.

The effective capacitance is the minimum capacitance value of a capacitor after taking into account variations resulting from tolerances, temperature, and dc bias effects. X5R- and X7R-type ceramic capacitors are recommended because these capacitors have minimal variation in value and ESR over temperature.

Although an input capacitor is not required for stability, good analog design practice is to connect a $0.1\mu\text{F}$ to $2.2\mu\text{F}$ capacitor from IN to GND. This capacitor counteracts reactive input sources and improves transient response, input ripple, and PSRR. An input capacitor is necessary if line transients greater than 10V in magnitude are anticipated.

8.1.2 TRANSIENT RESPONSE

As with any regulator, increasing the output capacitor size reduces over- and undershoot magnitude, but increases transient response duration

8.2 TYPICAL APPLICATION



Figure 1. Wide Input, Low- I_q Rail

8.2.1 DESIGN REQUIREMENTS

Table 1 summarizes the design requirements for Figure 1.

Table 1 summarizes the design requirements for Figure 1.

PARAMETER	DESIGN SPECIFICATION
V_{IN}	Up to 40V
V_{OUT}	1.8V/2.5V/3.3V/5V
$I_{(IN)}$ (no load)	$5\mu\text{A}$
I_{OUT} (max)	200mA

8.2.2 DETAILED DESIGN PROCEDURE

Select a 2.2μF, 10V output capacitor to satisfy the minimum output capacitance requirement with a 1.8V/2.5V/3.3V/5V dc bias.

Select a 1.0μF, 25V input capacitor to provide input noise filtering and eliminate high-frequency voltage transients.

8.2.3 APPLICATION CURVES

Load Transient (50mA to 150mA)
VIN=7V,VOUT=5V

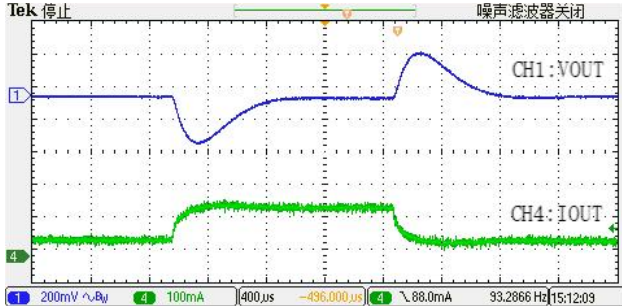

Power-up
VIN=7V,VOUT=5V

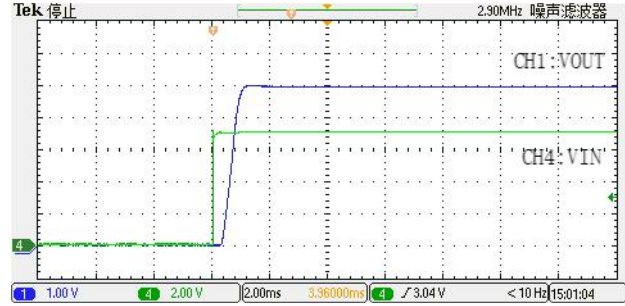

9 POWER SUPPLY RECOMMENDATIONS

This device is designed to operate with an input supply range of 4.5V to 40V. If the input supply is noisy, additional input capacitors with low ESR can help improve output noise performance.

9.1 POWER DISSIPATION

The ability to remove heat from the die is different for each package type, presenting different considerations in the printed circuit board (PCB) layout. The PCB area around the device that is free of other components moves the heat from the device to ambient air. Performance data for JEDEC low and high-K boards are given in the Thermal Information table. Using heavier copper increases the effectiveness in removing heat from the device.

The addition of plated through-holes to heat-dissipating layers also improves the heatsink effectiveness.

Power dissipation depends on input voltage and load conditions. Power dissipation (PDISS) is equal to the product of the output current and the voltage drop across the output pass element, as shown in Equation 1:

$$P_{DISS} = (V_{IN} - V_{OUT}) \times I_{OUT}$$

10 LAYOUT

10.1 LAYOUT GUIDELINES

Place input and output capacitors as close to the device pins as possible. To improve ac performance (such as PSRR, output noise, and transient response), GATEMODE recommends that the board be designed with separate ground planes for V_{IN} and V_{OUT} , with the ground plane connected only at the GND pin of the device. In addition, the ground connection for the output capacitor must be connected directly to the device GND pin.

10.1.1 THERMAL PROTECTION

Thermal protection disables the output when the junction temperature rises to approximately 165°C, allowing the device to cool. When the junction temperature cools to approximately 145°C, the output circuitry is again enabled. Depending on power dissipation, thermal resistance, and ambient temperature, the thermal protection circuit can cycle on and off. This cycling limits the dissipation of the regulator, protecting it from damage as a result of overheating.

Any tendency to activate the thermal protection circuit indicates excessive power dissipation or an inadequate heatsink. For reliable operation, limit junction temperature to 125°C, maximum. To estimate the margin of safety in a complete design (including heatsink), increase the ambient temperature until the thermal protection is triggered; use worst-case loads and signal conditions. For good reliability, thermal protection must trigger at least 35°C above the maximum expected ambient condition of the particular application. This configuration produces a worst-case junction temperature of 125°C at the highest expected ambient temperature and worst-case load. The GM73XX internal protection circuitry is designed to protect against overload conditions. This circuitry is not intended to replace proper heatsinking. Continuously running the GM73XX into thermal shutdown degrades device reliability.

10.2 LAYOUT EXAMPLE

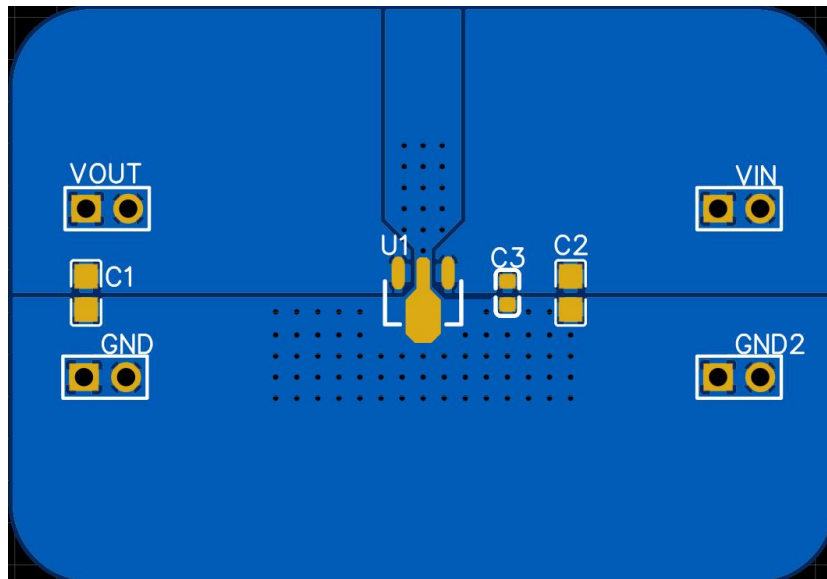

PACKAGE DIMENSIONS

SOT23-5

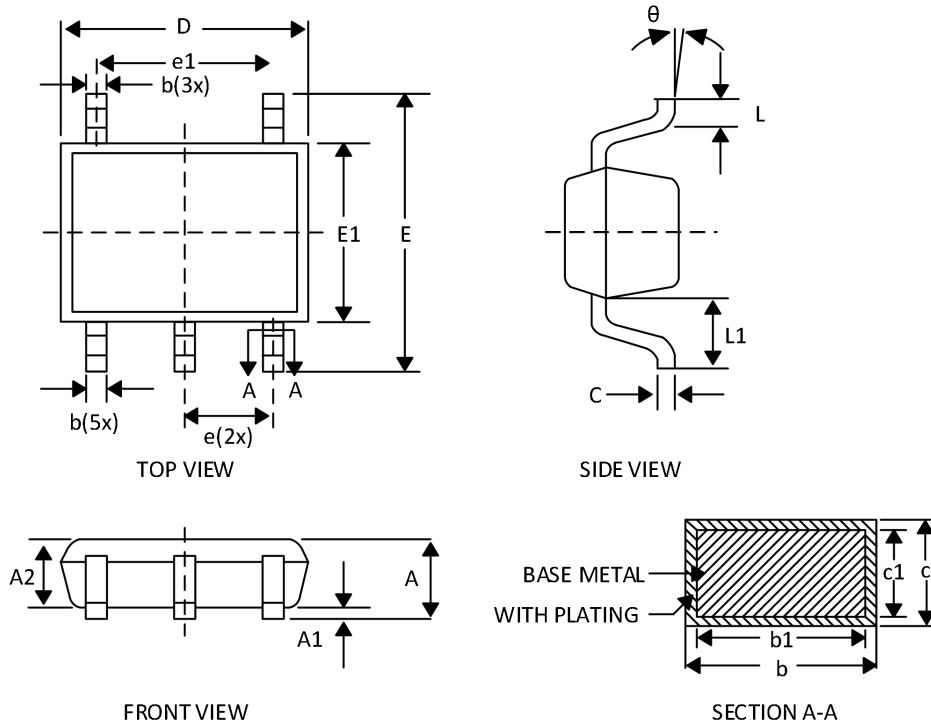

SYMBOL	MIN(mm)	NOM(mm)	MAX(mm)
A	-	-	1.25
A1	0.03	0.08	0.15
A2	1.05	1.10	1.15
b	0.27	-	0.35
b1	0.26	0.285	0.31
c	0.135	-	0.23
c1	0.127	0.152	0.178
D	2.82	2.92	3.02
E	2.60	2.90	3.00
E1	1.50	1.62	1.70
e	0.95BSC		
e1	1.90BSC		
L	0.35	0.45	0.55
L1	0.49	0.64	0.79
θ	0°	-	8°

PACKAGE DIMENSIONS

SOT89-3

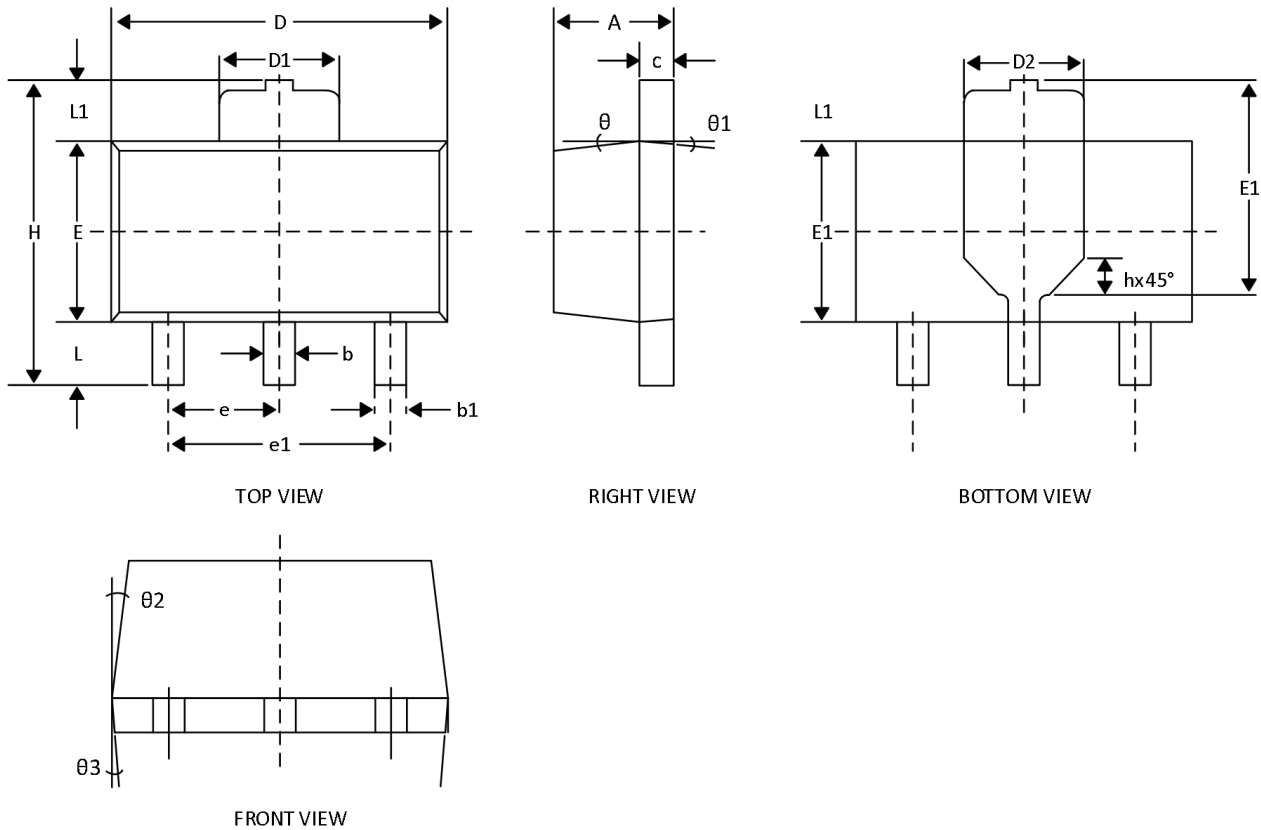

SYMBOL	MIN(mm)	NOM(mm)	MAX(mm)
A	1.400	1.500	1.600
b	0.420	0.480	0.540
b1	0.340	0.400	0.460
c	0.350	0.400	0.450
D	4.400	4.500	4.600
D1	1.600	1.700	1.800
D2	1.650	1.750	1.850
E	2.400	2.500	2.600
E1	2.814	2.964	3.114
e	1.500 BSC		
e1	3.000 BSC		
H	4.050	4.150	4.250
h	0.275	0.425	0.575
L	0.680	0.825	0.930
L1	0.680	0.825	0.930
θ	6° BSC		
θ1	3° BSC		
θ2	6° BSC		
θ3	3° BSC		

PACKAGE DIMENSIONS

SOT23-3

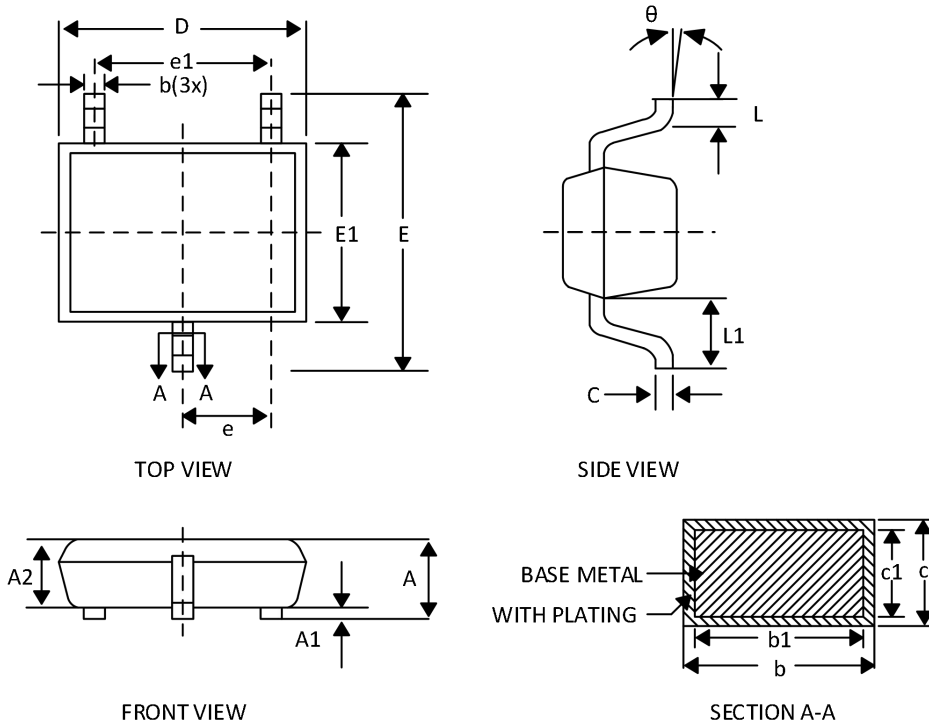

SYMBOL	MIN(mm)	NOM(mm)	MAX(mm)
A	-	-	1.25
A1	0.03	0.08	0.15
A2	1.05	1.10	1.15
b	0.27	-	0.35
b1	0.26	0.285	0.31
c	0.135	-	0.23
c1	0.127	0.152	0.178
D	2.82	2.92	3.02
E	2.60	2.90	3.00
E1	1.50	1.62	1.70
e	0.95 BSC		
e1	1.90 BSC		
L	0.35	0.45	0.55
L1	0.49	0.64	0.79
θ	0°	-	8°

PACKAGE DIMENSIONS
SOT223

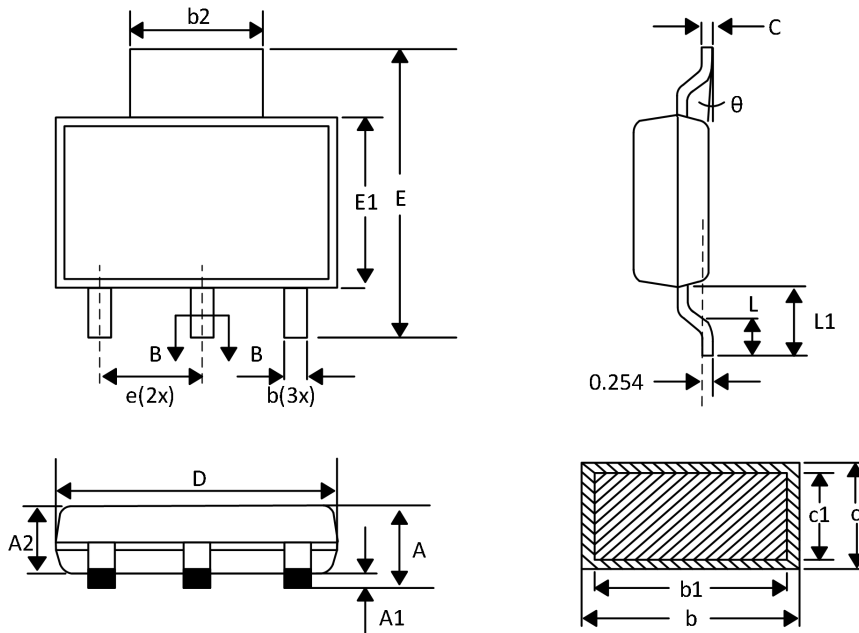

SYMBOL	MIN(mm)	NOM(mm)	MAX(mm)
A	--	--	1.80
A1	0.03	0.09	0.15
A2	1.45	1.50	1.65
b	0.66	--	0.76
b1	0.60	0.71	0.74
b2	2.95	2.998	3.05
c	0.20	--	0.35
c1	0.19	0.203	0.22
D	6.40	6.50	6.60
E	6.85	7.00	7.15
E1	3.40	3.50	3.60
e	2.286 BSC		
L	0.76	0.96	1.16
L1	1.70	--	1.80
θ	0°	--	8°

PACKAGE DIMENSIONS
TO-252-3

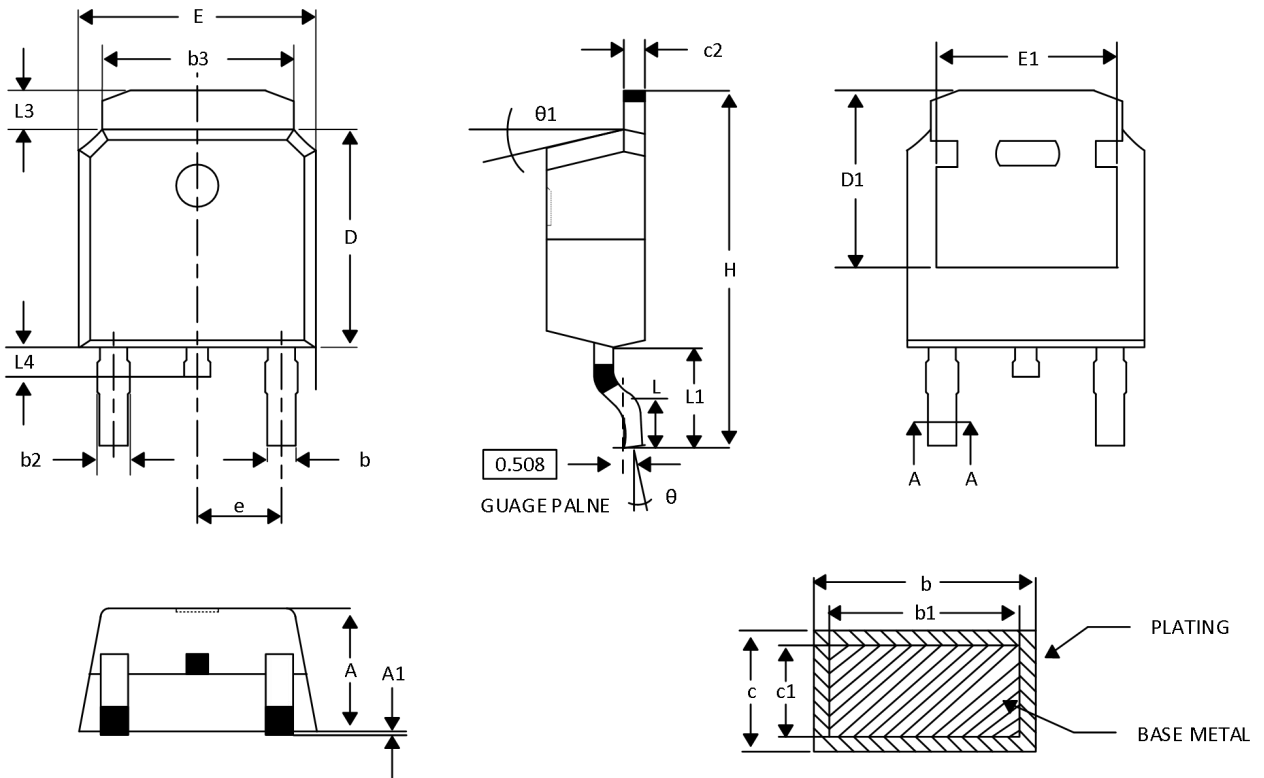

SYMBOL	MIN(mm)	NOM(mm)	MAX(mm)
A	2.20	2.30	2.40
A1	0.00	--	0.12
b	0.65	--	0.89
b1	0.64	0.69	0.79
b2	0.76	--	1.10
b3	5.20	5.33	5.46
c	0.48	--	0.60
c1	0.47	0.50	0.55
c2	0.48	--	0.60
D	6.00	6.10	6.20
D1	5.21	--	--
E	6.50	6.60	6.70
E1	4.32	--	--
e	2.29 BSC		
H	9.70	--	10.20
L	1.40	1.55	1.70
L1	2.743 REF		
L3	0.90	--	1.27
L4	0.60	0.80	1.00
θ	0°	--	10°
θ_1	0°	--	15°

ORDER INFORMATION

Order number	Output voltage	Marking information	package	Transport media,quantity	MSI GRADE	GREEN
GM7318K	Fixed 1.8V	B1AXXX	SOT23-5-EN	T&R,3000	L3	Rohs
GM7325K	Fixed 2.5V	B1BXXX	SOT23-5-EN	T&R,3000	L3	Rohs
GM7333K	Fixed 3.3V	B1CXXX	SOT23-5-EN	T&R,3000	L3	Rohs
GM7350K	Fixed 5.0V	B1DXXX	SOT23-5-EN	T&R,3000	L3	Rohs
GM7318YA	Fixed 1.8V	B2AXXX	SOT23-5-NC	T&R,3000	L3	Rohs
GM7325YA	Fixed 2.5V	B2BXXX	SOT23-5-NC	T&R,3000	L3	Rohs
GM7333YA	Fixed 3.3V	B2CXXX	SOT23-5-NC	T&R,3000	L3	Rohs
GM7350YA	Fixed 5.0V	B2DXXX	SOT23-5-NC	T&R,3000	L3	Rohs
GM7318YB	Fixed 1.8V	B4AXXX	SOT23-5(B)	T&R,3000	L3	Rohs
GM7325YB	Fixed 2.5V	B4BXXX	SOT23-5(B)	T&R,3000	L3	Rohs
GM7333YB	Fixed 3.3V	B4CXXX	SOT23-5(B)	T&R,3000	L3	Rohs
GM7350YB	Fixed 5.0V	B4DXXX	SOT23-5(B)	T&R,3000	L3	Rohs
GM7318TA	Fixed 1.8V	GM7318TA	SOT89-3	T&R,1000	L3	Rohs
GM7325TA	Fixed 2.5V	GM7325TA	SOT89-3	T&R,1000	L3	Rohs
GM7333TA	Fixed 3.3V	GM7333TA	SOT89-3	T&R,1000	L3	Rohs
GM7350TA	Fixed 5.0V	GM7350TA	SOT89-3	T&R,1000	L3	Rohs
GM7318TB	Fixed 1.8V	GM7318TB	SOT89-3(B)	T&R,1000	L3	Rohs
GM7325TB	Fixed 2.5V	GM7325TB	SOT89-3(B)	T&R,1000	L3	Rohs
GM7333TB	Fixed 3.3V	GM7333TB	SOT89-3(B)	T&R,1000	L3	Rohs
GM7350TB	Fixed 5.0V	GM7350TB	SOT89-3(B)	T&R,1000	L3	Rohs
GM7318F	Fixed 1.8V	B3AXXX	SOT23-3	T&R,3000	L3	Rohs
GM7325F	Fixed 2.5V	B3BXXX	SOT23-3	T&R,3000	L3	Rohs
GM7333F	Fixed 3.3V	B3CXXX	SOT23-3	T&R,3000	L3	Rohs
GM7350F	Fixed 5.0V	B3DXXX	SOT23-3	T&R,3000	L3	Rohs
GM7333E	Fixed 3.3V	GM7333E	SOT223	T&R,4000	L3	Rohs
GM7350E	Fixed 5.0V	GM7350E	SOT223	T&R,4000	L3	Rohs
GM7333H	Fixed 3.3V	GM7333H	TO-252-3	T&R,3000	L3	Rohs
GM7350H	Fixed 5.0V	GM7350H	TO-252-3	T&R,3000	L3	Rohs

VERSION MODIFICATION RECORD

Version	Modify the description	Page	Time	Modify personnel
1.1	1.Original:GM73XX_1.0 →GM73XX_1.1		On October 27,2025	Kang
	2.Supports 200mA Peak Output→Supports 250mA Peak Output	1		
	3.The GM73XX is characterized over the recommended operating output current range up to 150mA. The internal current limit begins to limit the output current at a minimum of 250mA of output current. The GM73XX continues to operate for output currents between 150mA and 200mA but some data sheet parameters may not be met.→The GM73XX is characterized over the recommended operating output current range up to 200mA. The internal current limit begins to limit the output current at a minimum of 250mA of output current. The GM73XX continues to operate for output currents between 200mA and 250mA but some data sheet parameters may not be met.	6		
	4.I _{OUT(MAX)} =150mA→I _{OUT(MAX)} =200mA.	7		
1.2	1.Original:GM73XX_1.1 →GM73XX_1.2		On January 21,2026	Kang
	2.Added the pinout Diagram, thermal resistance information, package information and ordering information for the SOT223 package.	2,3,13, 15		
	3.Added the pinout Diagram, thermal resistance information, package information and ordering information for the TO-252-3 package.	2,3,14, 15		