



岳阳县中正电子有限公司

YUE YANG XIAN ZHONGZHEGN ELECTRONCS DEVELOPMENT CO.,LTD

規格承認書

SPECIFICATIONS FOR APPROVAL

客戶名稱

CUSTOMER

規格敘述

EMI Capacitors Class X2, 275VAC

DESCRIPTION

中正料號

MPX104K275AP10T6Y-ZZ01; MPX224K275AP10T6Y-ZZ01

ZHONGZHENG P/N

客戶料號

CUSTOMER P/N

承認編號

ZZ20260525001

APPROVAL NO

發行日期

2026/5/25

ISSUED DATE

版次

1.0

VERSION

厂址：湖南省岳阳市岳阳县柏祥镇工业区

TEL: (86) 0730-7128775 FAX: (86) 0730-7552728

广州业务办：广东省广州市番禺区南村镇万博二路广州金地壹阅府 24 栋 702 房

TEL: (86) 020-84716357 FAX: (86) 020-84716353

客户签承栏 CUSTOMER CONFIRM

中正承办栏 ZZEC OFFER

核准

APPROVED BY

检验

CHECKED BY

承认签章

STAMP

核准

APPROVED BY

审核

MADE BY

工程签章

STAMP

黄六伟

魏星

樊国军

日期 DATE

日期 DATE

2026/5/25

SPECIFICATION	YUE YANG XIAN ZHONGZHEGN ELECTRONCS DEVELOPMENT CO.,LTD
客戶名稱 CUSTOMER	
中正型號 ZHONGZHENG TYPE	

產品尺寸圖 PRODUCT DIMENSIONS

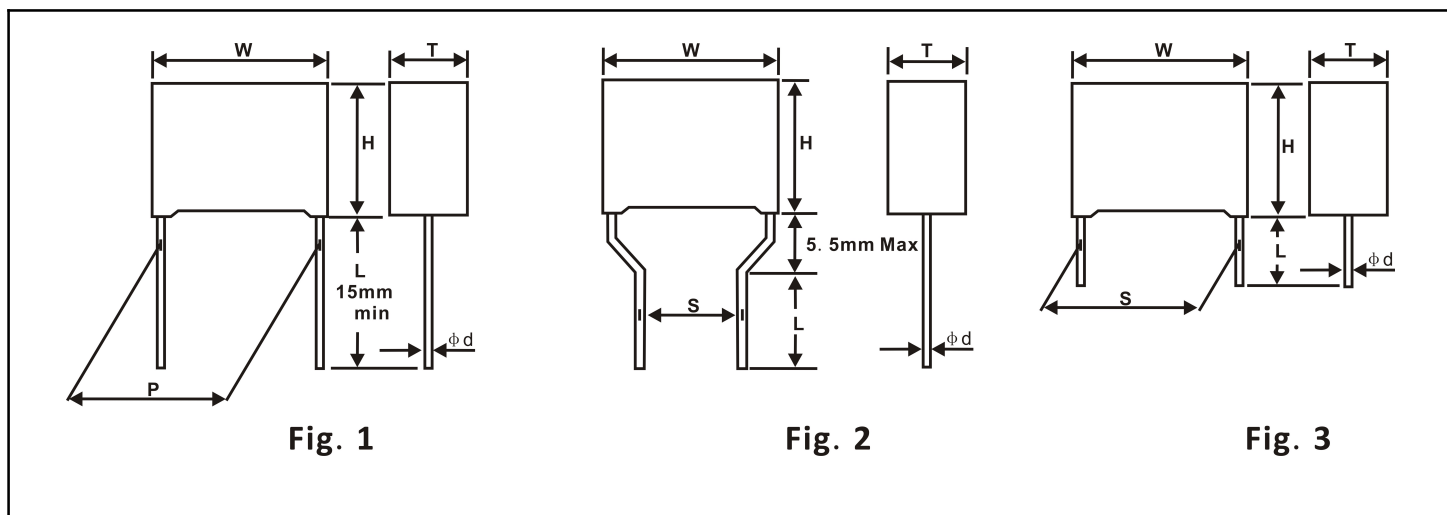

中正產品型號 ZHONGZHENG P/N	容值 CAP.(uF)	標志 Symbol	公差 Tol.±%	電壓 R.V. (VAC)	尺寸毫米為單位 Dimensions in mm							圖示 Fig.	備注 Note
					寬 W ±0.5	高 H ±0.5	厚 T ±0.5	腳距 P ±0.5	腳距 S ±0.5	線徑φd ±0.05	腳長 L ±2		
MPX104K275AP10T6Y-ZZ01	0.1	104	10	275	13	12	6	10	-	0.6	20	1	黃盒黃膠

文件履歷

DOCUMENT HISTORY

承認書編號

APPROVAL NO.

ZZ20260525001

日期	版次	說明	審核	確認	製表
2026.5.25	V1.0	首次样品承认书	魏星	樊国军	杨煜华

NO.	項目 ITEM	說明 DESCRIPTIONS
1	承認範圍 SCOPE	本規格適用於中正之要求 This specifications cover the requirements of ZHONGZHENG 金屬化聚丙烯薄膜 Metallized Polypropylene Film 交流電容器 (抑制電源電磁干擾用固定電容器/等級-X2) AC Capacitor (Interference Suppressors Class-X2).
2	各測量皆於標準大氣下進行 STANDARD ATMOSPHERIC CONDITIONS FOR MAKING MEASUREMENTS	
2.1	環境溫度 AMBIENT TEMPERATURE	15°C 至 35°C (如對結果有任何疑問, 該測量環境溫度應為+20 ± 5°C之間) 15°C to 35°C (If there is any doubt on the results, the measurements shall be made at +20 ± 5°C)
2.2	相對溼度 RELATIVE HUMIDITY(R.H.)	45%至 75% (如對結果有任何疑問, 該測量相對溼度應為 60% to 70%之間) 45%to 75% (If there is any doubt on the results, the measurements shall be made at 60% to 70%)
2.3	大氣壓力 AIR PRESSURE	86 千帕至 106 千帕之 86 kpa to 106 kpa
2.4	工作溫度範圍 OPERATING TEMPERATURE RANGE	於-40°C至+110°C間, 電容可在額定電壓下持續運作 -40°C to +110°C for which the capacitor can be operated continuously at rated voltage.
3	結構 CONSTRUCTION	
3.1	電介質 DIELECTRIC	金屬化聚丙烯薄膜 Metallized Polypropylene Film
3.2	噴金屬 METAL SPRAY	特殊焊料 Special Solder
3.3	導線 LEAD WIRE	鍍錫銅包鋼線 Copper-clad Steel Wire
3.4	環氧樹脂 EPOXY RESIN	UL 94V-0 耐燃等級
3.5	塑料外殼 PLASTIC CASE	UL 94V-0 耐燃等級
		
4	打印 MARKING	
4.1	製造商標誌 MANUFACTURER'S SYMBOL	ZZEC 表示為岳阳县中正电子有限公司制造
4.2	型號或材質 TYPE OR MATERIAL	"MPX"代表"MPX"類型 "MPX" stands for "MPX" type
4.3	電容類別 CAPACITOR CLASS	"X2" 代表"X2"等級 "X2 stands for "X2" class
4.4	靜電容量 NOMINAL CAPACITANCE	容量用 EIA 三碼表示 Capacitance Expressed in 3-digit (EIA) code.
4.5	容量容許差值 TOLERANCE	J (±5%), K (±10%), M (±20%)
4.6	額定電壓 RATED VOLTAGE	交流電壓 310V in VAC rating. (50/60Hz)
4.7	電容氣候類別 / 阻燃等級 CLIMATIC CATEGORY	40/110/56/B or GLFB
4.8	國際認證 APPROVAL MARKS	
4.9	製造番號 MANUFACTURE CODE	
		範例 example 

5 电气特性 ELECTRICAL CHARACTERISTICS				
NO	项目 ITEM		性能 PERFORMANCE	测试条件 TEST CONDITIONS
5.1	耐压 (TV) Withstand Voltage	端子之间 Between Terminals	应无异常 Shall be no abnormality 非标准小型化产品施加 1.5-2 倍额定直流电压, 测试 60 秒 Non-standard miniaturized products apply 1.5-2 times rated DC voltage for 60 seconds 注意: 非标产品不适用 4.3.倍额定直流电压.	施 1400V 额定直流电压测试 60 秒(电压应以不超过 150V/s 的速率从零升高到试验电压, 时间应从达到电压时计算, 在结束时, 电压应减少到接近零, 并且电容器应通过一个适当的电阻放电) Apply 1400V (DC) for 60 sec (Should be no more than 150V/s rate increased from zero to the test voltage, testing time, meets the test voltage should be calculated at the end of the trial, the voltage should be reduced to zero and the capacitor through a resistor of appropriate discharge.
		端子与外壳之间 Between Terminals & Enclosure	应无异常 Shall be no abnormality	2 倍额定电压+1,500VAC, 测试 2 到 5 秒 最小值 2,000VAC Apply 2*Ur+1,500VAC for 2 to 5 sec. Min. 2,000VAC
	脉冲电压测试 Pulse voltage	Applied pulses 脉冲电压	最大脉冲次数: 24 次, 脉冲间隔时间 ≥ 10s, 脉冲电压峰值 2.5kV (适用于 $C \leq 1 \mu F$; $C > 1 \mu F$ 时, 承受的脉冲电压为 $2.5 / \sqrt{C_N}$ kV)	用监视器监视, 有三次或更多次的脉冲波形表示电容器未发生自愈性击穿(如果监视器显示有三次连续的脉冲波形表示电容器未发生自愈性击穿, 则可停止施加脉冲) 注意: 非标产品不适用.
5.2	介质损耗 (DF) Dissipation Factor		于 1KHz 时 $\leq 0.001(0.1\%)$ $\leq 0.001(0.1\%)$ at 1 KHz	测量频率: $\pm 2\%$; 测量电压: ≤ 1 rms Measuring Frequency: $\pm 2\%$ Measuring Voltage: ≤ 1 Vrms..
5.3	容量 (CAP) Capacitance		偏差值如标示(于 $+20 \pm 5^\circ C$)。 Within the tolerance specified (at $+20 \pm 5^\circ C$).	测量频率: $\pm 2\%$; 测量电压: ≤ 1 rms Measuring Frequency: $\pm 2\%$ Measuring Voltage: ≤ 1 Vrms..
5.4	绝缘电阻 (I.R.) Insulation Resistance		$\geq 15,000$ Mohm ($C \leq 0.33 \mu f$) 容值 $\leq 0.33 \mu f$ 时, 绝缘电阻 $\geq 15,000 M \Omega$ $\geq 5,000$ Mohm * $\mu F / C$ ($C > 0.33 \mu f$) 容值 $> 0.33 \mu f$ 时, 绝缘电阻 $\geq 5,000 M \Omega * \mu F / C$	应加电压 100 伏 充电时间 60 ± 5 秒。 Vt=100 VDC Charge Time : 60 ± 5 sec.
5.5	焊料附着性 Soldering Property		焊料覆盖面积应超过导线表面 圆周 90%。 More than 90% of circumferential surface of lead wire shall be covered with new solder.	焊接温度为: $+265 \pm 5^\circ C$ 浸焊时间为: 3 ± 0.5 秒 Soldering temperature: $+265 \pm 5^\circ C$ Immersion duration: 3 ± 0.5 sec.
6 机械特性 MECHANICAL CHARACTERISTICS				
6.1	端子强度 Terminal Strength	引张强度 Tensile Strength	应无异常。 Shall be no abnormality	沿着轴向和引出方向, 施加 1 公斤力量, 保持 10 ± 1 秒。 Apply 1.0Kg for 10 ± 1 sec. to the terminal in the axial direction and acting in a direction away from the body.

7 耐久特性 ENDURANCE CHARACTERISTICS				
NO.	項目 ITEM	說明 DESCRIPTIONS		
7.1	溫度變化循環 Temperature Cycle	外觀 Appearance	應當無顯著變化 Shall be no remarkable change	共 5 次溫度循環測試, 循環條件: 1. +20 ± 2°C 持續 3 分鐘 2. -40 ± 3°C 持續 30 分鐘 3. +20 ± 2°C 持續 3 分鐘 4. +110 ± 2°C 持續 30 分鐘 5. +20 ± 2°C 持續 3 分鐘 試驗後放置於室內 1.5 ± 0.5 小時後再進行量測。 Test Temperature Cycle: Total 5 cycles. Each cycle includes 1. 20 ± 2°C for 3 min. 2. -40 ± 3°C for 30 min. 3. +20 ± 2°C for 3 min. 4. +110 ± 2°C for 30min. 5. +20 ± 2°C for 3 min. After test, allow it stay alone for 1.5 ± 0.5 Hrs. at ordinary condition before making measurements.
		耐壓 Withstand Voltage	應滿足 NO.5.1 shall satisfy NO.5.1	
		容值變化率 (ΔC/C) Capacitance Change Rate	變化率小於 ±5% Within ±5% of the value before test	
		介質損耗 Dissipation Factor	於 1KHz 時: 最大值為 0.002 (0.2%) @ 1KHz: 0.002 (0.2%) max.	
		絕緣電阻 (I.R.) Insulation Resistance	≥50%的限制值在 NO.5.4 ≥50% of the limit value of NO.5.4	
7.2	耐乾熱試驗 Dry Heat Resistance	外觀 Appearance	應當無顯著變化 Shall be no remarkable change	試驗溫度: +110 ± 2°C 測試時間: 16 + 1/-0 小時 Test Temperature: +110 ± 2°C Test Duration: 16 + 1/-0 hrs.
		耐壓 Withstand Voltage	應滿足 NO.5.1 Shall satisfy NO.5.1	
		容值變化率 (ΔC/C) Capacitance Change Rate	變化率小於 ±5% Within ±5% of the value before test	
		介質損耗 Dissipation Factor	於 1KHz 時: 最大值為 0.002 (0.2%) @ 1KHz: 0.002 (0.2%) max.	
		絕緣電阻 (I.R.) Insulation Resistance	≥50%的限制值在 NO.5.4 ≥50% of the limit value of NO.5.4	
7.3	耐乾寒試驗 Cold Resistance	外觀 Appearance	應當無顯著變化 Shall be no remarkable change	試驗溫度: -40 ± 3°C 測試時間: 2 ± 1 小時 Test Temperature: -40 ± 3°C Test Duration: 2 ± 1 hrs.
		耐壓 Withstand Voltage	應滿足 NO.5.1 Shall satisfy NO.5.1	
		容值變化率 (ΔC/C) Capacitance Change Rate	變化率小於 ±5% Within ±5% of the value before test	
		介質損耗 Dissipation Factor	於 1KHz 時: 最大值為 0.002 (0.2%) @ 1KHz: 0.002 (0.2%) max.	
		絕緣電阻 (I.R.) Insulation Resistance	≥50%的限制值在 NO.5.4 ≥50% of the limit value of NO.5.4	

NO.	項目 ITEM	說明 DESCRIPTIONS		
7.4	耐濕絕緣 Damp Heat	外觀 Appearance	應當無顯著變化 Shall be no remarkable change	試驗溫度: +40 ± 2°C 試驗濕度: 90%至 95%相對濕度 試驗時間: 56 天 試驗後放置於室內 1.5 ± 0.5 小時後再進行量測。 Test Temperature: +40 ± 2°C. Test Humidity: 90% to 95% R.H. Test Duration: 56 days. After test, allow it stay alone for 1.5 ± 0.5 Hrs. at ordinary condition before making measurements.
		耐壓 Withstand Voltage	應滿足 NO.5.1 Shall satisfy NO.5.1	
		容值變化率 (ΔC/C) Capacitance Change Rate	變化率小於±5% Within ±5% of the value before test	
		介質損耗 Dissipation Factor	於 1KHz 時: 最大值為 0.002 (0.2%) @ 1KHz: 0.002 (0.2%) max.	
		絕緣電阻 (I.R.) Insulation Resistance	≥50%的限制值在 NO.5.4 ≥50% of the limit value of NO.5.4	
7.5	振動試驗 Vibration Resistance	外觀 Appearance	應無機械性損傷 Shall be no mechanical damage.	頻率變化: 10-55-10Hz 振動距離: 1.5 毫米. 試驗方向: X,Y,Z 試驗時間:每個方向 2+1/-0 小時 Frequency Change : 10-55-10 Hz Vibration Distance:1.5 mm. Test Direction : X,Y,Z Test Duration : 2+1/-0 hrs each direction
		連接強度 Connection strength	不得為短路或開路連接。 連接點應穩定。 Shall be no short-circuiting or open. The connection shall be stable.	
7.6	焊接耐熱 Soldering Heat Resistance	外觀 Appearance	應當無顯著變化 印字標誌應清晰 Shall be no remarkable change. The marking shall be legible.	預熱溫度: 100 ~120°C 預熱時間:最大為 60 秒 溫度升高:最大為 3°C/秒 錫爐溫度: +260 ± 5°C 浸焊時間: 5 ± 1 秒 浸焊深度:導線根部 4 ± 0.8 毫米 試驗後放置於室內 1.5 ± 0.5 小時後再進行量測。 Preheat Temp. : 100~120°C Preheat Duration : 60 sec. max. Temperature Increase by 3°C/sec. max. Soldering Temperature : +260 ± 5°C Immersion Duration : 5 ± 1sec. Immersion Depth : 4 ± 0.8mm from roots. After test, allow it stay alone for 1.5 ± 0.5 Hrs. at ordinary condition before making measurements.
		端子間的耐電壓值 Withstand Voltage Between Terminals	應滿足 NO.5.1 Shall satisfy NO.5.1	
		容值變化率 (ΔC/C) Capacitance Change Rate	變化率小於 ±3% Within ±3% of the value before test	
		介質損耗 Dissipation Factor	於 1KHz 時: 最大值為 0.002 (0.2%) @ 1KHz: 0.002 (0.2%) max.	
		絕緣電阻 (I.R.) Insulation Resistance	≥50%的限制值在 NO.5.4 ≥50% of the limit value of NO.5.4	
		連接元件 Connection of Element	應穩定 Shall be stable	

NO.	項目 ITEM	性能 PERFORMANCE	測試條件 TEST CONDITIONS
7.7	耐久壽命 Endurance	外觀 Appearance	應當無顯著變化 Shall be no remarkable change
		耐壓 Withstand Voltage	應滿足 NO.5.1 Shall satisfy NO.5.1
		容值變化率 ($\Delta C/C$) Capacitance Change Rate	變化率小於 $\pm 10\%$ Within $\pm 10\%$ of the value before test
		介質損耗 Dissipation Factor	於 1KHz 時: 最大值為 @ 1KHz Cr $\leq 1\mu F$: 0.008 (0.8%) max. Cr $> 1\mu F$: 0.005 (0.5%) max.
		絕緣電阻 (I.R.) Insulation Resistance	$\geq 50\%$ 的限制值在 NO.5.4 $\geq 50\%$ of the limit value of NO.5.4
		耐壓 Withstand Voltage	應滿足 NO.5.1 Shall satisfy NO.5.1
		容值變化率 ($\Delta C/C$) Capacitance Change Rate	變化率小於 $\pm 5\%$ Within $\pm 5\%$ of the value before test
		介質損耗 Dissipation Factor	於 1KHz 時: 最大值為 0.002 (0.2%) @ 1KHz: 0.002 (0.2%) max.
		絕緣電阻 (I.R.) Insulation Resistance	$\geq 50\%$ 的限制值在 NO.5.4 $\geq 50\%$ of the limit value of NO.5.4

試驗溫度: $+110 \pm 2^\circ C$
 測試電壓: 1.25 倍的額定電壓
 試驗時間: 1,000 小時
 每小時將電壓升至 1,000VAC · 持續 0.1 秒
 每個電容分別通過一個 $47\Omega \pm 5\%$ 電阻。
 Test Temperature: $+110 \pm 2^\circ C$
 Test Voltage: 1.25 times* rated voltage.
 Test Duration: 1,000 Hrs.
 Once every hour the voltage is increased to 1000 V rms. For 0.1 sec. The test voltage is applied to each capacitor individually through a resistor of $47\Omega \pm 5\%$.

產品安規認證

PRODUCT SAFETY APPROVALS

标志 Mark	认证单位 Agent	应用标准 Standard	规格范围 Specification	证书号码 Certificate No.
	美国 / 加拿大 UL / CUL	UL EN 60384-14:2013 (AMD2016)	X2, 275/ 310/330 VAC 0.001 μF to 10 μF	UL-US-2427106-0
	欧盟 ENEC	EN 60384-14:2013 (AMD2016)	X2, 275/ 310/330 VAC 0.001 μF to 10 μF	ENEC-04959
	中国 CQC	IEC 60384-14: 2013 AMD1:2016	X2, 275/ 310/330 VAC 0.001 μF to 10 μF	CQC24001434015

Guideline Of Notabilia For The Usage Of Plastic Film Capacitors

塑膠薄膜電容器的使用上注意事項及指導

Plastic film capacitors use organic films for their dielectrics, thus the capacitors may fume or flame, depending on the circuit conditions they are in, when they are damaged by applying over-voltage or over-current.

塑膠薄膜電容器使用有機薄膜為介質，當使用超過額定電壓及額定電流，可能產生火焰，導致電容損壞，故請使用於正確的迴路。

1. Circuit Design 迴路設計

- ① Please use capacitors within the range of their characteristic ratings, only after confirming their operating and mounting environments.

請確認電容器的使用範圍僅止於明定之額定特性規範，請先確認電容器使用之環境是否符合規範。

- ② In case of selecting a capacitor, please select the most suitable one which fits to your operating conditions.

請依照適合的作業條件選擇相對應的電容器使用。

- ③ Capacitors used for Across-The-Line, Line-By-Pass and Antenna-Coupling to suppress noises in an equipment, the capacitors need to be approved by overseas Safety Standards or 'Electric Appliance and Material Control' by Ministry of international Trade and Industry.

電容器用於跨接，旁路迴路及天線耦合等抑制噪音的裝置，需通過海外安全標準或日本通商產業省之電器用品安全法。

- ④ An applying voltage to a capacitor, including the peak of surge and ripple voltage (D.C. voltage + A.C. Peak), cannot be exceeded the rating voltage.

電容器之應用電壓，包括突波和紋波電壓的峰值(直流電壓+交流峰值)不可超過額定電壓。

- ⑤ Do not apply a current over its permissible level. Also, make sure to check the surrounding temperature and inherent temperature rise of a capacitor since a permissible current can be restricted by those factors.

切勿使用超出電容器可承載之電流並檢查電容器周圍之溫度，因有許多因素會影響電流之變化，進而造成電容器之溫度上升。

- ⑥ Please contact Zhongzheng for further details, if mechanical resonance (hum) occurs to a capacitor.

如電容器的發出共振(嗡嗡)之噪音時，請與中正電子聯繫。

- ⑦ Do not conduct a rapid charge and discharge to a capacitor which may lead to characteristics degradations or break down of the capacitor.

請不要對電容器進行快速的充電和放電，此可能會導致電容器之特性退化或損壞。

2. Mounting 安裝

- ① Do not apply any exceeding tension or torsion to lead wires of a capacitor, during the mounting process.

請不要使用任何超過電容導線可承受之張力進行插件。

- ② Please mount a capacitor where it does not contact any other heating parts, high voltage parts and other parts.

請確認電容器使用環境，避免接觸任何其他升溫熱物件、高壓和其他部分料件。

- ③ Please conduct soldering process by strictly following the specified conditions.

進行焊接過程時，請嚴格遵循指定之焊接條件。

3. Case of an emergency 緊急情況

- ① If a fuming, a flaming or an unusual smell occurs from an equipment during its usage, please cut off the power supply by switching it off, pulling the plug out or other methods.

如使用設備有冒煙，火花或冒出不尋常之氣味，請切斷電源，拔掉插頭或以其它方法關閉設備。

4. Storing and handling 儲存和處理

- ① A storage needs to be kept indoors at $-10 \sim +40^{\circ}\text{C}$ and relative humidity of under 75% without any sudden temperature changes, direct sunlight and corrosive gas around.

需保存於 $-10 \sim 40^{\circ}\text{C}$ ，相對濕度低於75%並確保沒有任何突然的溫度變化，避免直接陽光之曝曬及接觸腐蝕性氣體之環境。

- ② Do not apply and exceeding vibration, shock (dropping) and pressure.

不應過度震動、碰撞和及外力的衝擊。

5. Rejection 報廢

- ① In case of rejecting capacitors, please seek for professionals who deal with the industrial wastes treatments.

對於報廢電容器，請找處理工業廢品之專業人士處理。

薄膜电容性能参数 Electrical Characteristics of Film Capacitor

1. 焊接温度与时间对比

Soldering Temperature VS Time

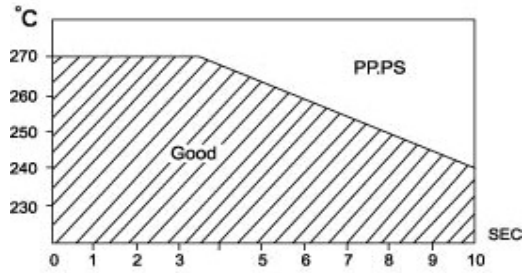
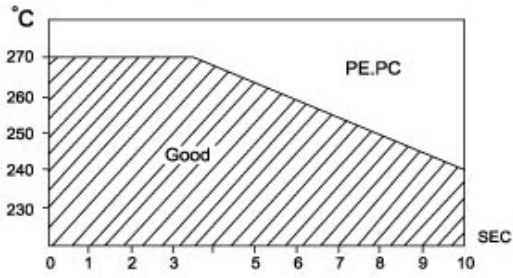

2. 温度性能

Temperature Characteristic

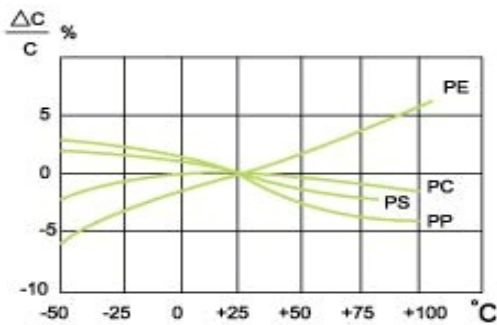

容量变化率与温度的关系

Capacitance vs. Temperature

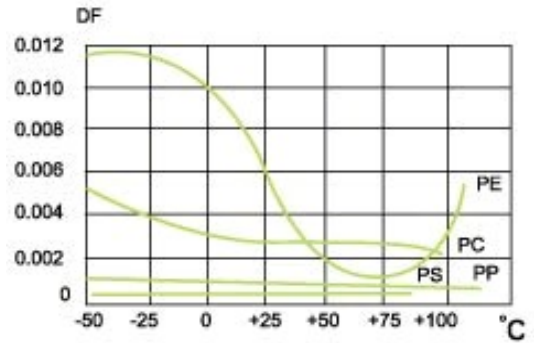

损耗角正切与温度的关系

Dissipation Factor vs. Temperature

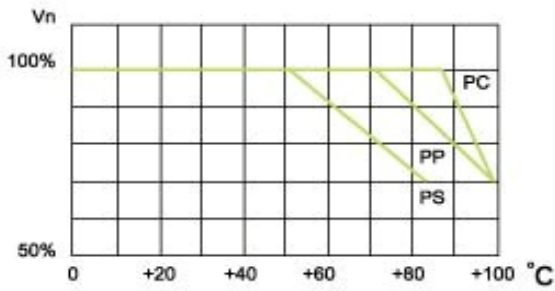

使用电压与温度的关系

Operation voltage vs. Temperature

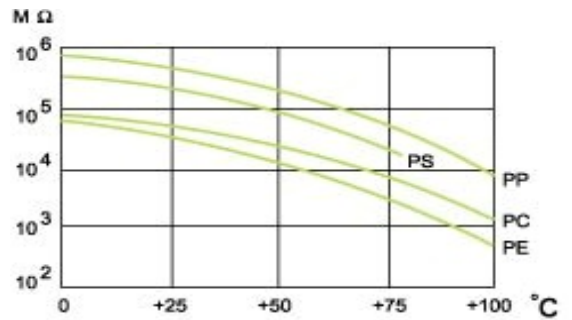

绝缘电阻与温度的关系

(CR value) IR vs. Temperature

3. 频率性能

Frequency Characteristics

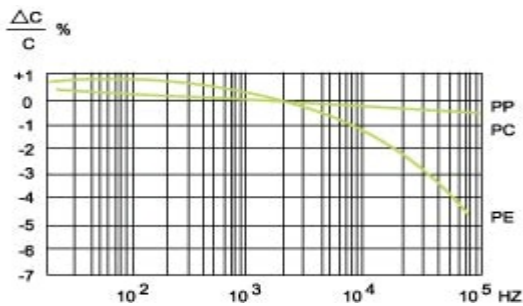

容量变化率与频率的关系

Capacitance vs. Frequency

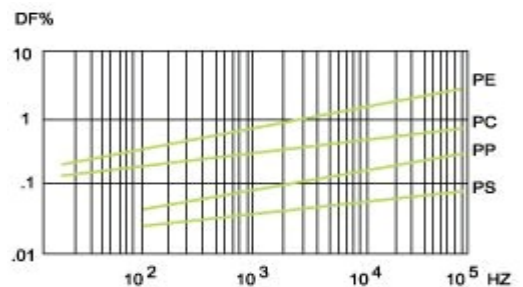

损耗角正切与频率的关系

Dissipation Factor vs. Frequency