



### Features

- High Blocking Voltage with Low On-Resistance
- High Speed Switching with Low Capacitance
- Easy to Parallel and Simple to Drive

### Benefits

- Higher system efficiency
- Reduce cooling requirements
- Increase power density
- Increase system switching frequency

### Applications

- Renewable Energy
- EV Battery Chargers
- High Voltage DC/DC Converters
- Switch Mode Power Supplies



Ordering Part Number	Package	Marking
HC2M0080120K	TO-247H-4L	HC2M0080120K

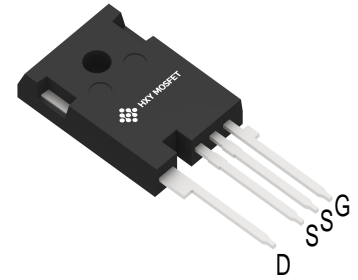

TO-247H-4L

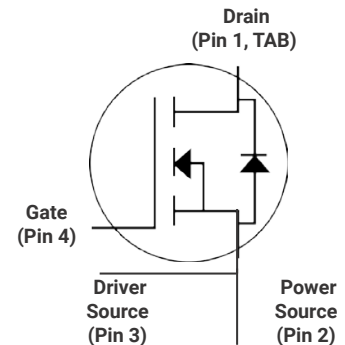

### Maximum Ratings ( $T_c = 25^\circ\text{C}$ unless otherwise specified)

Symbol	Parameter	Value	Unit	Test Conditions	Note
$V_{DSmax}$	Drain-Source Voltage	1200	V	$V_{GS}=0V, I_D=100\mu A$	
$V_{GSmax}$	Gate-Source Voltage	-10/+25	V	Absolute maximum values	
$V_{GSop}$	Gate-Source Voltage	-5/+20	V	Recommended operational values	
$I_D$	Continuous Drain Current	36	A	$V_{GS}=20V, T_c=25^\circ\text{C}$	Fig. 19
		24		$V_{GS}=20V, T_c=100^\circ\text{C}$	
$I_{D(pulse)}$	Pulsed Drain Current	80	A	Pulse width $t_p$ limited by $T_{Jmax}$	Fig. 22
$P_D$	Power Dissipation	192	W	$T_c=25^\circ\text{C}, T_J=150^\circ\text{C}$	Fig. 20
$T_J, T_{STG}$	Operating Junction and Storage Temperature	-55 to +150	$^\circ\text{C}$		
$T_L$	Solder Temperature, 1.6mm from case for 10s	260	$^\circ\text{C}$		
$M_d$	Mounting Torque, (M3 or 6-32 screw)	1	Nm		
		8.8	lbf-in		



**Electrical Characteristics** ( $T_C = 25^\circ\text{C}$  unless other

Symbol	Parameter	Min.	Typ.	Max.	Unit	Test Conditions	Note
$V_{(BR)DSS}$	Drain-Source Breakdown Voltage	1200	/	/	V	$V_{GS}=0V, I_D=100\mu A$	
$V_{GS(th)}$	Gate Threshold Voltage	2.0	2.4	4.0	V	$V_{DS}=V_{GS}, I_D=5mA$	Fig. 11
		/	1.8	/		$V_{DS}=V_{GS}, I_D=5mA, T_J=150^\circ\text{C}$	
$I_{DSS}$	Zero Gate Voltage Drain Current	/	1	100	$\mu A$	$V_{DS}=1200V, V_{GS}=0V$	
$I_{GSS+}$	Gate-Source Leakage Current	/	10	250	nA	$V_{DS}=0V, V_{GS}=25V$	
$I_{GSS-}$	Gate-Source Leakage Current	/	10	250	nA	$V_{DS}=0V, V_{GS}=-10V$	
$R_{DS(on)}$	Drain-Source On-State Resistance	/	80	98	m $\Omega$	$V_{GS}=20V, I_D=20A$	Fig. 4,5,6
		/	140	/		$V_{GS}=20V, I_D=20A, T_J=150^\circ\text{C}$	
$g_{fs}$	Transconductance	/	11.2	/	S	$V_{DS}=20V, I_{DS}=20A$	Fig. 7
		/	11.3	/		$V_{DS}=20V, I_{DS}=20A, T_J=150^\circ\text{C}$	
$C_{iss}$	Input Capacitance	/	1475	/	pF	$V_{GS}=0V$	Fig. 17,18
$C_{oss}$	Output Capacitance	/	94	/		$V_{DS}=1000V$	
$C_{rss}$	Reverse Transfer Capacitance	/	11	/		$f=1MHz$	
$E_{oss}$	$C_{oss}$ Stored Energy	/	52	/	$\mu J$	$V_{AC}=25mV$	Fig. 16
$E_{ON}$	Turn-On Switching Energy	/	564	/	mJ	$V_{DS}=800V, V_{GS}=-5V/20V$	
$E_{OFF}$	Turn-Off Switching Energy	/	260	/		$I_D=20A, R_{G(ext)}=2.5\Omega, L=200\mu H$	
$t_{d(on)}$	Turn-On Delay Time	/	9.3	/	ns	$V_{DS}=800V, V_{GS}=-5V/20V, I_D=20A$ $R_{G(ext)}=2.5\Omega, R_L=40\Omega$	
$t_r$	Rise Time	/	9.5	/			
$t_{d(off)}$	Turn-Off Delay Time	/	18	/			
$t_f$	Fall Time	/	7.6	/			
$R_{G(int)}$	Internal Gate Resistance	1	3.1	5.5	$\Omega$	$f=1MHz, V_{AC}=25mV$	
$Q_{GS}$	Gate to Source Charge	/	24	/	nC	$V_{DS}=800V$	Fig. 12
$Q_{GD}$	Gate to Drain Charge	/	15	/		$V_{GS}=-5V/20V$	
$Q_G$	Total Gate Charge	/	79	/		$I_D=20A$	

**Reverse Diode Characteristics** ( $T_C = 25^\circ\text{C}$  unless otherwise specified)

Symbol	Parameter	Typ.	Max.	Unit	Test Conditions	Note
$V_{SD}$	Diode Forward Voltage	3.6	/	V	$V_{GS}=-5V, I_{SD}=10A$	Fig. 8,9,10
		3.3	/		$V_{GS}=-5V, I_{SD}=10A, T_J=150^\circ\text{C}$	
$I_S$	Continuous Diode Forward Current	/	44	A	$T_C=25^\circ\text{C}$	
$t_{rr}$	Reverse Recover Time	35	/	ns	$V_R=800V, I_{SD}=20A$	
$Q_{rr}$	Reverse Recovery Charge	91	/	nC		
$I_{rrm}$	Peak Reverse Recovery Current	4.5	/	A		

**Thermal Characteristics**

Symbol	Parameter	Typ.	Max.	Unit	Test Conditions	Note
$R_{\theta JC}$	Thermal Resistance from Junction to Case	0.6	/	$^\circ\text{C/W}$		Fig. 21
$R_{\theta JA}$	Thermal Resistance from Junction to Ambient	/	40			



### Typical Performance

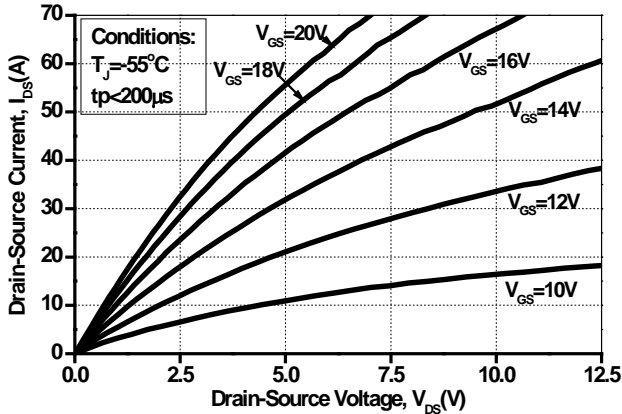

Figure 1. Output Characteristics  $T_J = -55^\circ\text{C}$

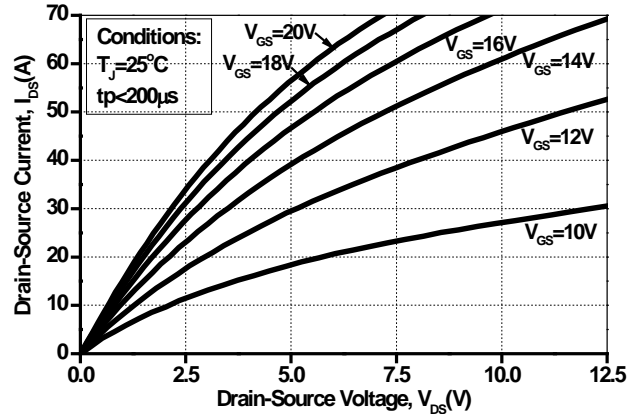

Figure 2. Output Characteristics  $T_J = 25^\circ\text{C}$

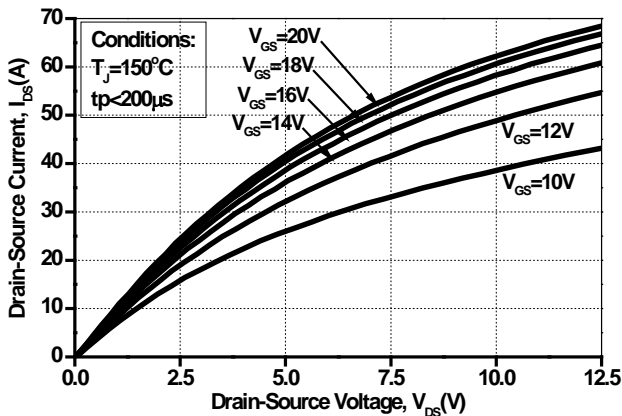

Figure 3. Output Characteristics  $T_J = 150^\circ\text{C}$

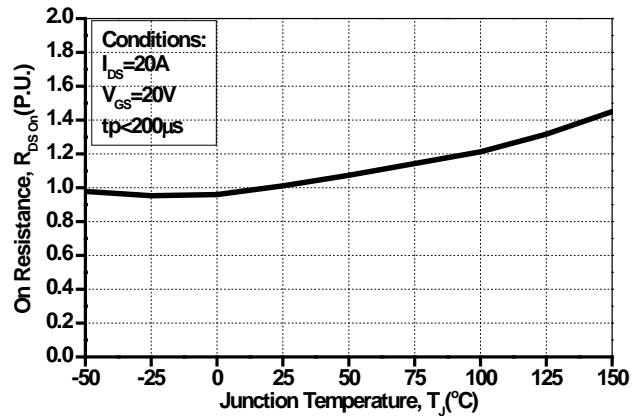

Figure 4. Normalized On-Resistance vs. Temperature

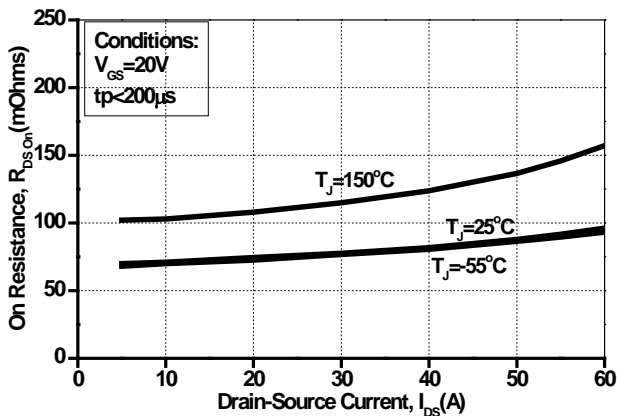

Figure 5. On-Resistance vs. Drain Current  
For Various Temperatures

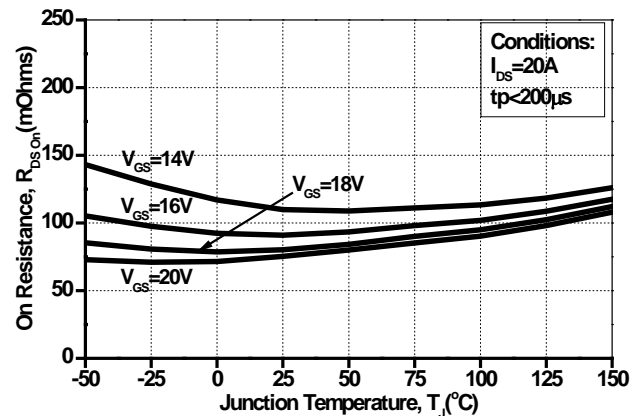

Figure 6. On-Resistance vs. Temperature  
For Various Gate Voltage



### Typical Performance

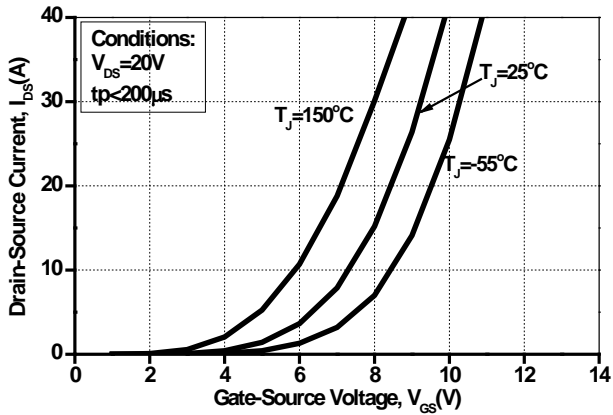

Figure 7. Transfer Characteristic for Various Junction Temperatures

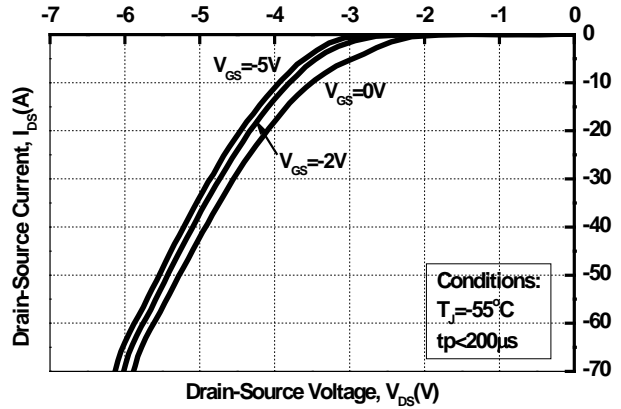

Figure 8. Body Diode Characteristic at -55 °C

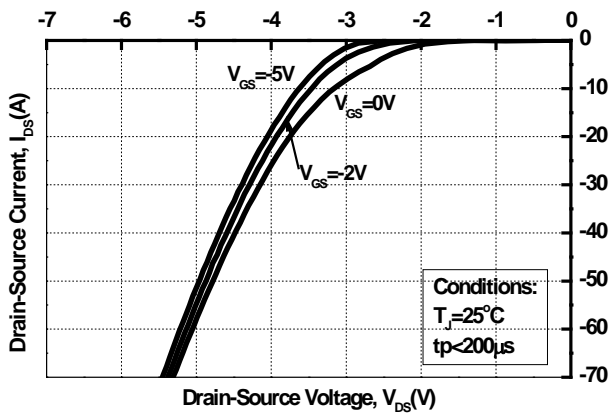

Figure 9. Body Diode Characteristic at 25 °C

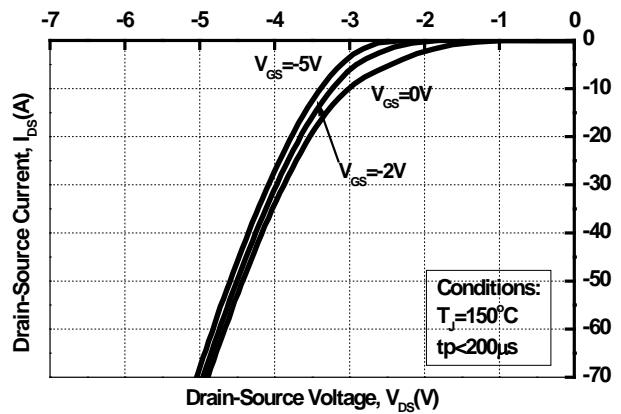

Figure 10. Body Diode Characteristic at 150 °C

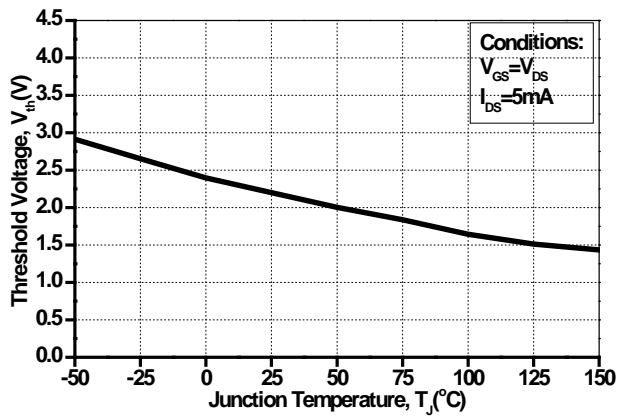

Figure 11. Threshold Voltage vs. Temperature

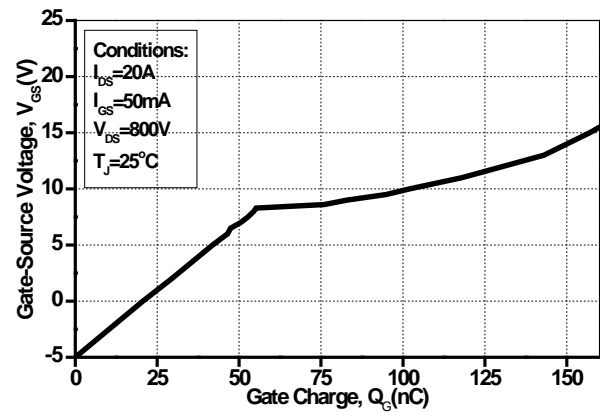

Figure 12. Gate Charge Characteristics



Typical Performance

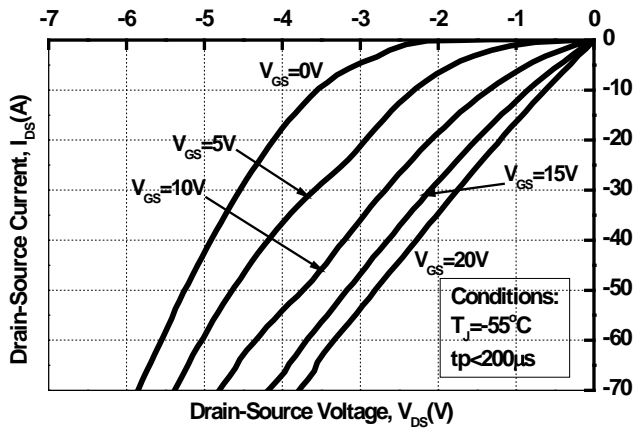

Figure 13. 3rd Quadrant Characteristic at -55 °C

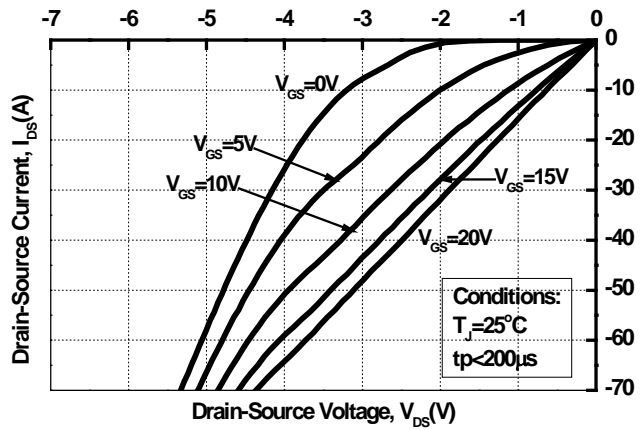

Figure 14. 3rd Quadrant Characteristic at 25 °C

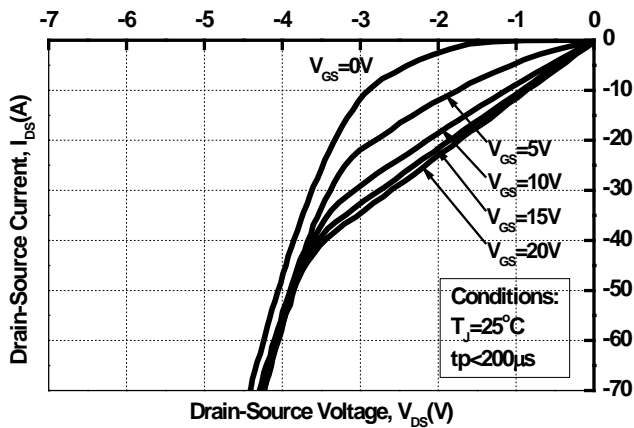

Figure 14. 3rd Quadrant Characteristic at 150 °C

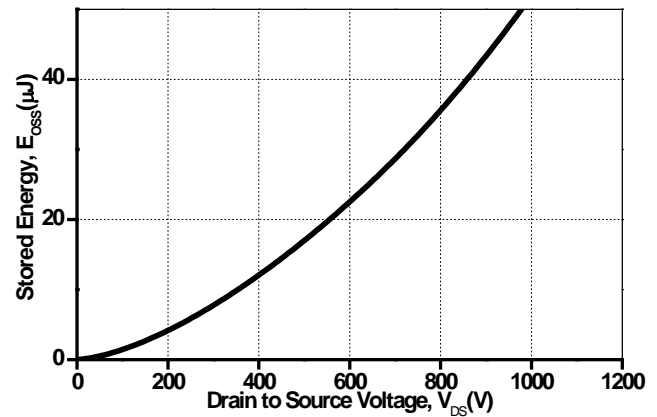

Figure 16. Output Capacitor Stored Energy

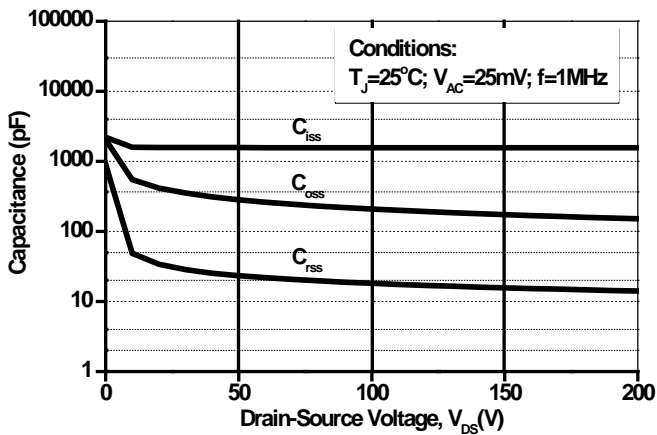

Figure 17. Capacitances vs. Drain-Source Voltage (0 - 200V)

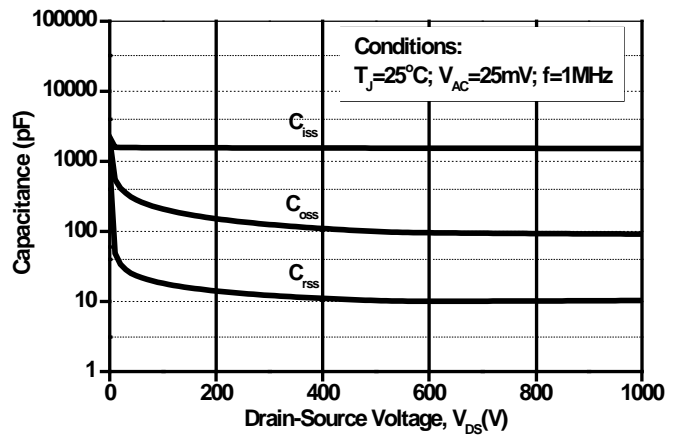

Figure 18. Capacitances vs. Drain-Source Voltage (0 - 1000V)



### Typical Performance

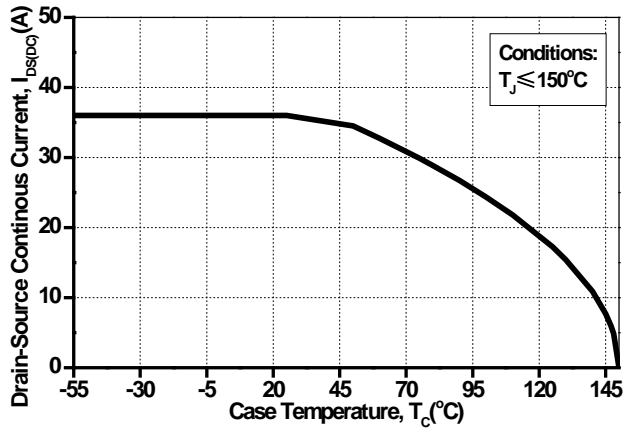

Figure 19. Continuous Drain Current Derating vs. Case Temperature

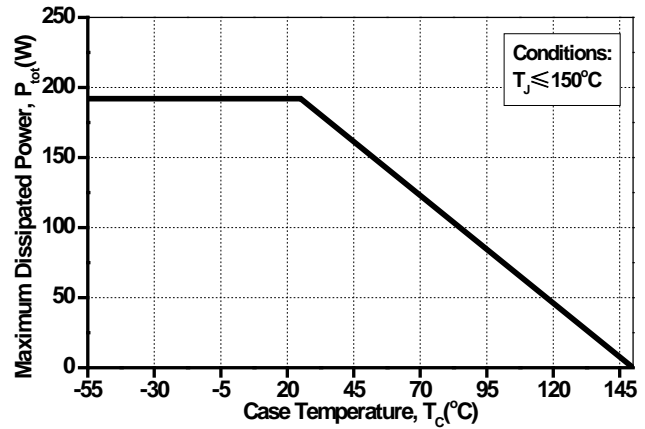

Figure 20. Maximum Power Dissipation Derating vs. Case Temperature

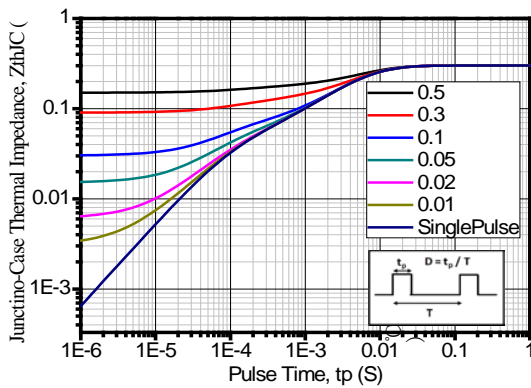

Figure 21. Transient Thermal Impedance (Junction - Case)

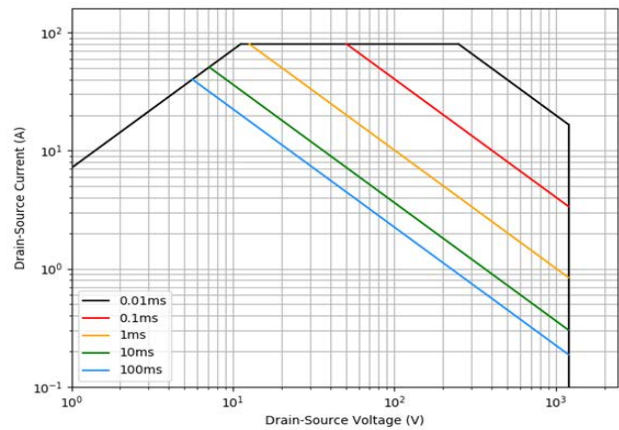

Figure 22. Safe Operating Area



### Test Circuit Schematic

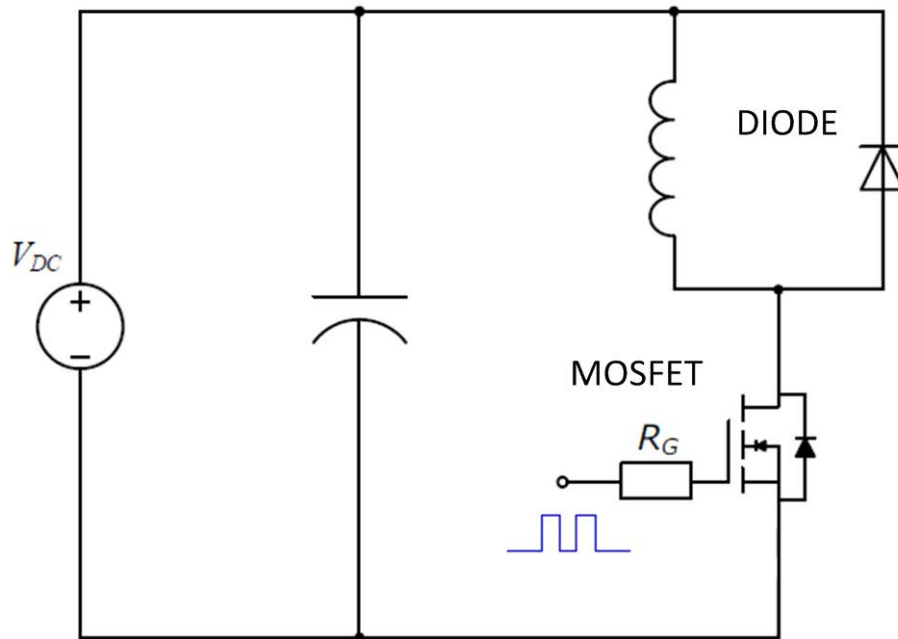
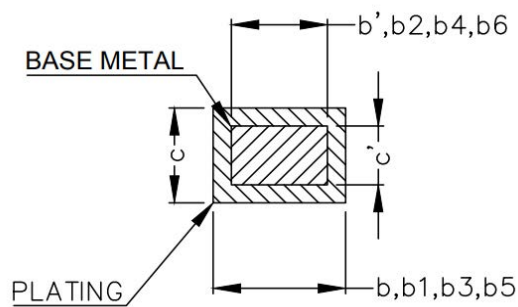
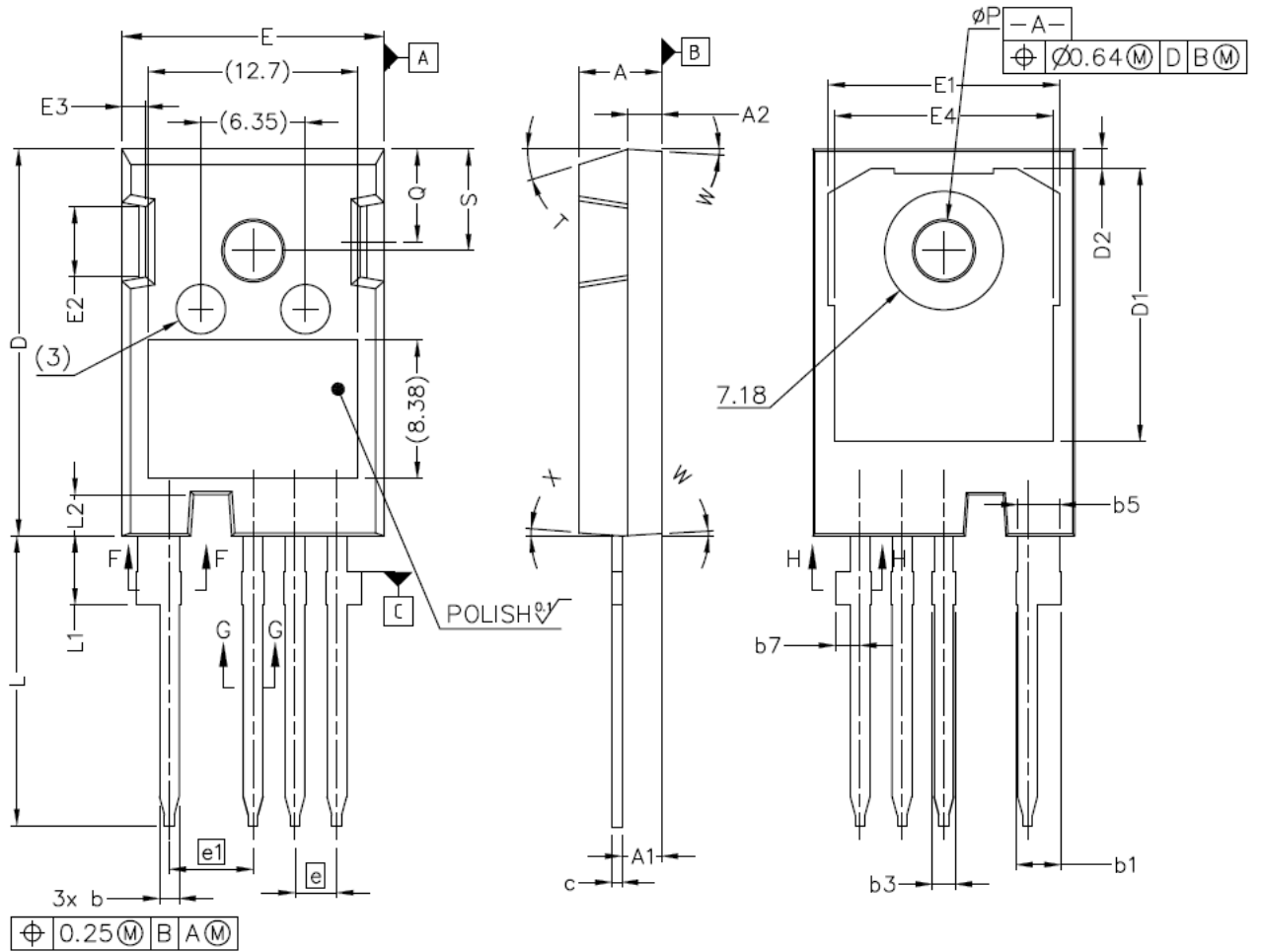

Figure 23. Clamped Inductive Switching  
Waveform Test Circuit



Package Dimensions

Package TO-247H-4L



SECTION "F-F", "G-G" AND "H-H"  
SCALE: NONE



**Package Dimensions**

Package TO-247H-4L

NOTE ;

1. ALL METAL SURFACES: TIN PLATED, EXCEPT AREA OF CUT
2. DIMENSIONING & TOLERANCEING CONFIRM TO ASME Y14.5M-1994.
3. ALL DIMENSIONS ARE IN MILLIMETERS. ANGLES ARE IN DEGREES.
4. 'N' IS THE NUMBER OF TERMINAL POSITIONS

SYM	MILLIMETERS	
	MIN	MAX
A	4.83	5.21
A1	2.29	2.54
A2	1.91	2.16
b`	1.07	1.28
b	1.07	1.33
b1	2.39	2.94
b2	2.39	2.84
b3	1.07	1.60
b4	1.07	1.50
b5	2.39	2.69
b6	2.39	2.64
b7	1.30	1.70
c`	0.55	0.65
c	0.55	0.68
D	23.30	23.60
D1	16.25	17.65
D2	0.95	1.25
E	15.75	16.13

SYM	MILLIMETERS	
	MIN	MAX
E1	13.10	14.15
E2	3.68	5.10
E3	1.00	1.90
E4	12.38	13.43
e	2.54 BSC	
e1	5.08 BSC	
N*	4	
L	17.31	17.82
L1	3.97	4.37
L2	2.35	2.65
∅ P	3.51	3.65
Q	5.49	6.00
S	6.04	6.30
T	17.5° REF.	
W	3.5° REF.	
X	4° REF.	

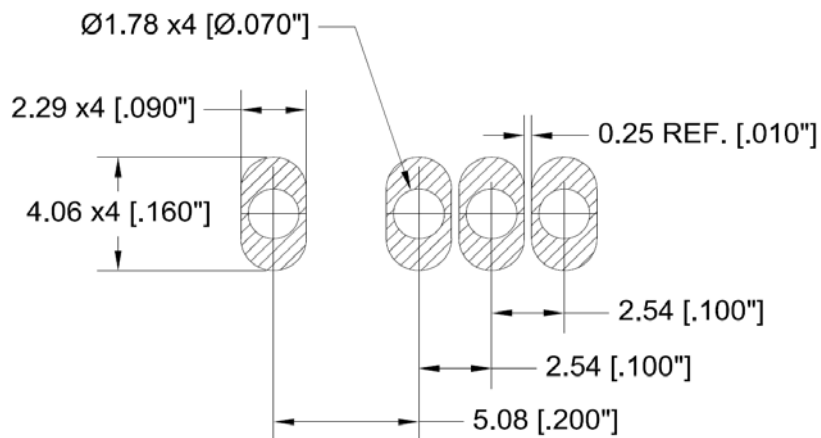



### Attention

- Any and all HUA XUAN YANG ELECTRONICS products described or contained herein do not have specifications that can handle applications that require extremely high levels of reliability, such as life-support systems, aircraft's control systems, or other applications whose failure can be reasonably expected to result in serious physical and/or material damage. Consult with your HUA XUAN YANG ELECTRONICS representative nearest you before using any HUA XUAN YANG ELECTRONICS products described or contained herein in such applications.
- HUA XUAN YANG ELECTRONICS assumes no responsibility for equipment failures that result from using products at values that exceed, even momentarily, rated values (such as maximum ratings, operating condition ranges, or other parameters) listed in products specifications of any and all HUA XUAN YANG ELECTRONICS products described or contained herein.
- Specifications of any and all HUA XUAN YANG ELECTRONICS products described or contained herein stipulate the performance, characteristics, and functions of the described products in the independent state, and are not guarantees of the performance, characteristics, and functions of the described products as mounted in the customer's products or equipment. To verify symptoms and states that cannot be evaluated in an independent device, the customer should always evaluate and test devices mounted in the customer's products or equipment.
- HUA XUAN YANG ELECTRONICS CO.,LTD. strives to supply high-quality high-reliability products. However, any and all semiconductor products fail with some probability. It is possible that these probabilistic failures could give rise to accidents or events that could endanger human lives, that could give rise to smoke or fire, or that could cause damage to other property. When designing equipment, adopt safety measures so that these kinds of accidents or events cannot occur. Such measures include but are not limited to protective circuits and error prevention circuits for safe design, redundant design, and structural design.
- In the event that any or all HUA XUAN YANG ELECTRONICS products(including technical data, services) described or contained herein are controlled under any of applicable local export control laws and regulations, such products must not be exported without obtaining the export license from the authorities concerned in accordance with the above law.
- No part of this publication may be reproduced or transmitted in any form or by any means, electronic or mechanical, including photocopying and recording, or any information storage or retrieval system, or otherwise, without the prior written permission of HUA XUAN YANG ELECTRONICS CO.,LTD.
- Information (including circuit diagrams and circuit parameters) herein is for example only ; it is not guaranteed for volume production. HUA XUAN YANG ELECTRONICS believes information herein is accurate and reliable, but no guarantees are made or implied regarding its use or any infringements of intellectual property rights or other rights of third parties.
- Any and all information described or contained herein are subject to change without notice due to product/technology improvement, etc. When designing equipment, refer to the "Delivery Specification" for the HUA XUAN YANG ELECTRONICS product that you intend to use.